

Transfer Unit 90° (U90)

300 916 001	PB160 – 200 / UB160 - 400
300 917 001	PB200 – 400 / UB to 400
300 918 001	PB200 – 400 / UB >400
300 939 001	PB160 – 200 / UB >400

Transfer Unit 180° (U180K)

300 921 001	PB160 – 200 / UB160 – 400
300 922 001	PB _≤ 200 – 280 / UB160 – 400
300 923 001	PB160 – 200 / UB >400
300 924 001	PB200 – 280 / UB >400

Transfer Unit 180° (U180G)

300 925 001	PB280 – 400 / UB to 400
300 948 001	PB280 – 400 / UB >400

Transfer Unit 1 ½ -fold

STEIN Workpiece Transport System

Operating instructions

Attention all installation, operating and maintenance personnel -
always keep these instructions by the transfer unit!

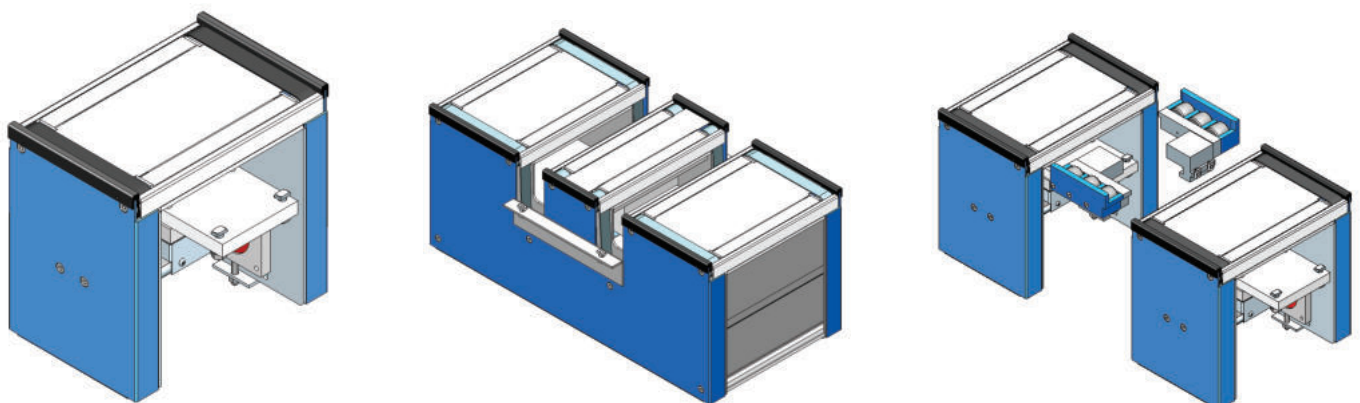

© by STEIN Automation

STEIN Automation reserves the copyright in these documents.

Original language of the documentation: German

These documents may not be altered, distributed, reproduced or transferred to third parties without the prior written permission of STEIN Automation.

STEIN Automation GmbH & Co. KG

Carl-Haag-Straße 26
78054 VS-Schwenningen, Germany

Telephone: (+)49 (0)7720 / 8307 – 0

Publication date: march 2020

We reserve the right to make changes to the design and construction

Contents

1	Abbreviations and symbols	4
1.1	Explanation of safety and warning notices	4
2	Introduction	5
2.1	Short description	6
2.2	Descriptions and models of the transfer units.....	7
2.3	Descriptions and models of the drive sets.....	8
2.4	Initial inspection	9
2.5	Complaints.....	9
2.6	Warranty	9
3	Safety information	10
3.1	General safety information	10
3.2	Appropriate use and liability exclusions	10
3.3	Foreseeable misuse	11
3.4	Residual danger	11
3.5	Safety information for installation and repair work	13
4	Technical description	14
4.1	Scope of delivery	14
4.2	WT orientation	16
4.3	System components	17
5	Installing the transfer unit.....	19
5.1	Procedure	19
5.2	Preparation	19
5.3	Installing the transfer unit.....	20
5.4	Fitting the stopping devices.....	21
5.5	Connecting the transfer unit to the mains supply.....	22
5.6	Connecting the transfer unit to the compressed air supply.....	23
5.7	Connecting the stoppers	24
5.8	Installing safety equipment.....	24
6	Initial operation	24
7	Transfer unit operation.....	25
8	Faults	27
8.1	Troubleshooting problems	27
9	Cleaning, inspection, maintenance	28
9.1	Cleaning.....	28
9.2	Inspection.....	29
9.3	Maintenance	29
10	Dimension sheet.....	30
11	Spare parts.....	32
11.1	300 916 001 Transfer unit 90° - PB160-200 / UB160-400.....	32
11.2	300 917 001 Transfer unit 90° - PB200-400 / UB to 400.....	34
11.3	300 918 001 Transfer unit 90° - PB200-400 / UB > 400	36
11.4	300 939 001 Transfer unit 90° - PB160-200 / UB >400	38
11.5	300 931 001 Attachment of two transfer units 90° (Soft Move)	41
11.6	300 921 001 Transfer unit 180° - PB160-200 / UB160 - 400.....	42
11.7	300 922 001 Transfer unit 180° - PB≥200-280 / UB160 - 400	45
11.8	300 923 001 Transfer unit 180° - PB160-200 / UB >400	48
11.9	300 924 001 Transfer unit 180° - PB200-280 / UB >400.....	51
11.10	300 925 001 Transfer unit 180° - PB280-400 / UB to 400.....	54
11.11	300 948 001 Transfer unit 180° - PB280-400 / UB >400	55
11.12	300 919 001 Transfer unit 90° 1 ½-fold - for Wafer carrier.....	56
11.13	300 920 001 Transfer unit 90° 1 ½-fold.....	58
11.14	930 191 001 Transfer unit 90° - with 4G read head right.....	60

11.15	930 187 001 Transfer unit 90° - with 4G read head left	63
11.16	930 146 001 Transfer unit 90° - with 4G read head right, HGL valve	66
12	Accessories	69
12.1	Drive motors - drive sets	69
13	Appendix	81
13.1	Technical Specifications	81

1 Abbreviations and symbols

- ☐ Action symbol
- ☐ 1 symbol for actions which must be carried out in a specified sequence.
- ⇒ Consequence or result of an action
- List
- U90 Transfer unit 90°
- U180G Transfer unit 180° large
- U180K Transfer unit 180° small
- OI Operating instructions
- WT Workpiece carrier
- BE Conveyor
- Fig. Figure
- PB Workpiece carrier width
- UB Transfer width



This sign indicates information that will allow the transfer unit to be used more effectively and more economically.

1.1 Explanation of safety and warning notices

The following safety notices indicate all actions where there is danger to life and limb for machine operators or their colleagues.

Strictly comply with these instructions and act with particular care in these cases. Pass the safety notices on to all other users.



DANGER

The sign indicating DANGER means immediate danger!

The hazard will result in serious injury to personnel or death.



WARNING

The sign indicating WARNING means potential danger!

The hazard may result in serious injury to personnel or death.



CAUTION

The sign indicating CAUTION means a potentially dangerous situation!

The hazard may result in injury to personnel.

In the text, the safety notice frequently appears with a picture to explain the source of the hazard.



CRUSHING HAZARD!

This symbol gives warning of a location where there is a risk of being crushed.



HIGH ELECTRICAL VOLTAGE!

This symbol gives warning of electrical voltage.

It appears for all working and operating procedures that must be followed precisely, in order to avoid injury to personnel or damage to the system through high voltage.

Other warning signs:



ATTENTION

This sign indicates warnings which, if ignored, will cause a hazard to the machine.



Protective clothing must be worn!

Wear your personal safety clothing:

Safety footwear, hard hat, goggles and safety gloves.



Environmental protection

This sign indicates warnings that will help to avoid harming the environment.

2 Introduction

The safety of all persons who come into contact with the transfer unit depends fundamentally on knowing how the transfer unit functions. Therefore:

Read these operating instructions before using the equipment for the first time.

This operating manual contains important information which will ensure the correct, economical and safe operation of your transfer unit.

The operating instructions must be treated with care and kept safe. Any illegible or missing operating instructions or safety signs at or on the transfer unit must be replaced immediately.

i

Unless separately specified, the same information that applies to the transfer unit described below, applies to transfer units that are not described in detail.

2.1 Short description

Transfer units are built into the STEIN300 Workpiece Transport System.
The transfer unit transfers workpiece carriers from one conveyor to another.

In conjunction with the Workpiece Transport System, the transfer unit 90°/180° enables:

- the replacement of grid-free and rectangular WTs (e. g: 160x400) between conveyors,
- diversion from the WT 90° to the transverse section,
- transfer from the WT 180° parallel to the main section to the feed / return path,
- diversion of WTs to the main section.

The transfer unit 90° consists of:

Fig. 2-1:
Transfer unit 90°
System components

- 1 Retaining plates
- 2 Lifting device
- 3 Drive motor

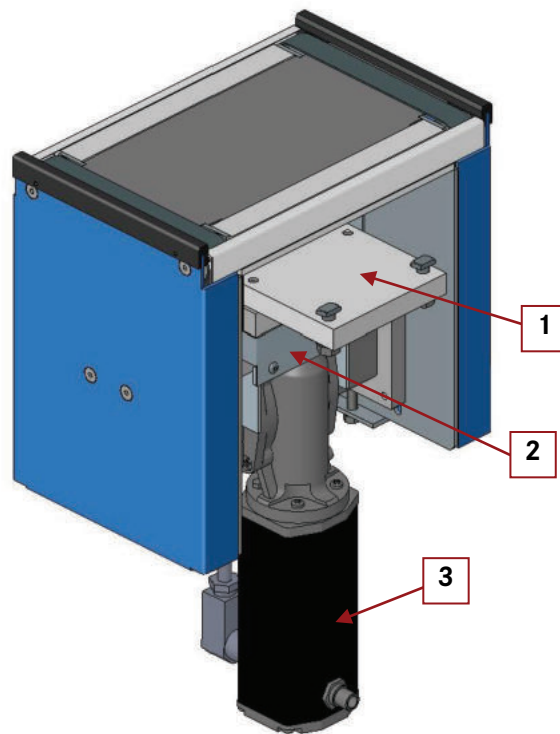

2.2 Descriptions and models of the transfer units



Depending on the WTS application the transfer units are available in a variety of configurations and models.

Description	Abbreviation	Article no.	Dimensions
Transfer unit 90°	U90	300 916 001	PB160 - 200 / UB160 - 400
Transfer unit 90°	U90	300 917 001	PB200 - 400 / UB to 400
Transfer unit 90°	U90	300 918 001	PB200 - 400 / UB >400
Transfer unit 90°	U90	300 939 001	PB160 - 200 / UB >400
Transfer unit 180°	U180K	300 921 001	PB160 - 200 / UB160 - 400
Transfer unit 180°	U180K	300 922 001	PB200 - 280 / UB160 - 400
Transfer unit 180°	U180K	300 923 001	PB160 - 200 / UB >400
Transfer unit 180°	U180K	300 924 001	PB200 - 280 / UB >400
Transfer unit 180° - U90 in pairs	U180G	300 925 001	PB280 - 400 / UB to 400
Transfer unit 180° - U90 in pairs	U180G	300 948 001	PB280 - 400 / UB >400
Transfer unit 1 ½-fold (Wafer carrier)	U90 1.5	300 919 001	PB206 - 400 / UB to 400
Transfer unit 1 ½-fold	U90 1.5	300 920 001	PB160 - 400 / UB to 400
Transfer unit 90° with 4G read head right	U90 LK4G r	930 191 001	
Transfer unit 90° with 4G read head left	U90 LK4G l	930 187 001	
Transfer unit 90° with 4G read head right with HGL valve	U90 LK4G r HGL	930 146 001	

2.3 Descriptions and models of the drive sets

i

Depending on the WTS application the transfer units are available with a variety of drive sets.

Description	Article no.	Motor variant
Drive set for U90	300 932 001	AC WEG basic motor / hanging
Drive set for U90	300 968 001	AC WEG basic motor / fixed
Drive set for U90	300 963 001	AC WEG motor / hanging
Drive set for U90	300 967 001	AC WEG motor / fixed
Drive set for U90	300 965 001	EC WEG motor / hanging
Drive set for U90 / U180	300 969 001	EC WEG motor / fixed
Drive set for U90	300 938 001	EC EBM motor / hanging
Drive set for U90	300 970 001	EC EBM motor / fixed
Drive set for U180	300 935 001	AC WEG motor / hanging
Drive set for U180	300 964 001	AC WEG basic motor / hanging
Drive set for U180	300 936 001	EC WEG motor / hanging
Drive set for U180	300 937 001	EC EBM motor / hanging

2.4 Initial inspection

The transfer unit is bubble-wrapped and securely transported in a solid box. Alternatively, the transfer unit can be pre-assembled in the conveyor.

- Unpack all the components supplied.



Environmental protection

Dispose of all packaging material in an environmentally responsible way.

Then carry out an initial inspection.

Check that:

- the delivery is complete in accordance with the enclosed delivery note
- components have not been damaged or lost in transit.

2.5 Complaints

In order for claims for damages caused in transit to be accepted, follow this procedure:

- Inform the freight company.
- Draw up a damage report giving the following details
 - Name and address of recipient
 - Item or order number
 - A description of the damage.
- Send components, if possible in their original packaging, with the damage report, back to the manufacturer.

2.6 Warranty

We guarantee the transfer unit and its spare parts for a warranty term as prescribed by law or for the warranty period set out in the supply agreement commencing from the date of delivery.

During this warranty period we will replace any components defective in manufacture or materials free of charge.

STEIN Automation's general warranty conditions also apply.

3 Safety information

3.1 General safety information

- Transfer units from STEIN Automation are high-quality products, manufactured in accordance with standard engineering practice. The transfer units left the manufacturing plant in a perfectly safe technical condition.
- All the models of the transfer units comply with the requirements of UVV, the German accident prevention regulations.
- To maintain this situation, installation staff, users and service technicians must observe the notices and warnings contained in these operating instructions.
- Conveyors must only be installed and repaired by authorised personnel who have been trained by STEIN Automation.
- Only genuine spare parts from STEIN Automation may be used when carrying out repairs to the transfer units.

3.2 Appropriate use and liability exclusions

The transfer units must only

- be built into STEIN 300 conveyor systems. Compatibility is only assured with STEIN 300 conveyor modules.
- be operated together with suitable workpiece carriers with permitted dimensions and weights,
- be operated indoors,
- be operated in dry areas,
- be used in areas where there is no risk of explosion.



DANGER

The transfer units may not, under any circumstances whatsoever, be operated in explosive or flammable environments.

No potentially explosive goods or hazardous materials may be transported.

Fig.: 3-1:
Maximum
loads:

90° transfer unit
180° transfer unit

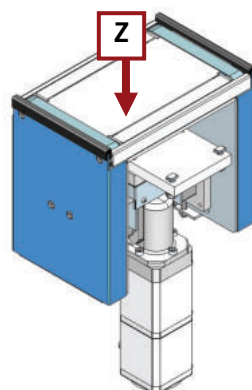

90° transfer unit

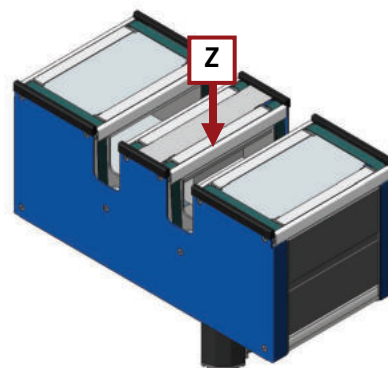

180° transfer unit

For the 90° transfer unit the permitted loading is

- in the Z axis: 12 N (WT + workpiece) if load is centred and under a STEIN working pressure of 4 bar.

For the 180° transfer unit K the permitted loading is

- in the Z axis: 12 N (WT + workpiece) if load is centred and under a STEIN working pressure of 4 bar.

Unauthorised interventions, alterations or repairs carried out to the transfer units invalidate the guarantee.

STEIN Automation accepts no liability for any damage caused by unauthorised interventions, alterations or repairs.

3.3 Foreseeable misuse



DANGER

It is prohibited

to transport products or workpieces with the transfer unit other than those approved.

to transport parts without workpiece carriers

This can lead to unforeseeable operating conditions and related dangers.

The transfer units must not be used

- in queue mode.
- be used to stop workpiece carriers,
- be used to separate workpiece carriers



STEIN Automation accepts no liability for damages that might arise due to misuse of the system.

3.4 Residual danger



DANGER

The transfer unit must be integrated in the EMERGENCY STOP circuit of the higher level system controller.

The transfer units are manufactured using state-of-the-art technology and to recognised safety standards. Nevertheless their use can lead to dangerous situations for users or third parties or to impairments of the system and other material assets.



WARNING

The protective guards of the lift the station may not be removed in automatic operating mode.

There is a risk of injury if the system is operated without protective guards.

All protective equipment must always be fully installed and functioning. The protective guards may only be removed by the maintenance personnel during maintenance and repair work.

If the transfer unit is used improperly, the following injuries can result:



WARNING

Crushing due to:

Jamming occurring between the components of the transfer unit that move linearly

Jamming occurring between the WT and the guide track or rails,

Getting drawn in or clothing getting wound around components.

The lift station may only be operated with or while enclosed by protective guards.



CAUTION

Hazardous areas may arise while the conveyor is in operation. There is a risk of crushing due to

jamming between the workpiece carriers,

being drawn in and clothing being wound around components, or

the characteristics of the product being transported.

Fig. 3-2:
Possible areas for
- jamming,
- getting drawn in or clothing wound around components.

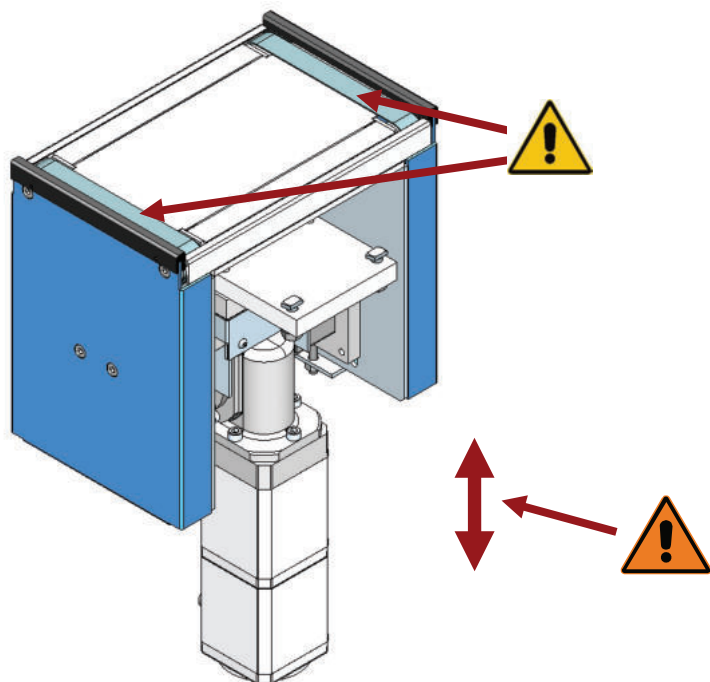

3.5 Safety information for installation and repair work



DANGER

In the area of the transfer unit due to an unexpected start up!



DANGER

**HIGH ELECTRICAL VOLTAGE!
Electric shock hazard!**

Follow the procedure below before starting any maintenance work:

- 1 Before carrying out any installation or repair task, disconnect the relevant transfer unit from its electrical power supply.
- 2 Disconnect the Workpiece Transport System from its compressed air supply.
- 3 Put up warning signs to prevent the system being started up while installation and repair work is being done.
- 4 Remove all workpiece carriers from the affected transfer unit!
- 5 Carry out the work
 - in accordance with the descriptions in this documentation,
 - complying with relevant safety and accident prevention regulations and
 - in a technically correct manner and with the greatest possible accuracy.
- 6 After completing installation or repair work, carry out a test run of the entire system and check that all the safety equipment is functioning correctly.



DANGER

**Never operate the transfer unit in the event of
missing or non-functioning safety equipment and / or
damaged components / parts.**

4 Technical description

4.1 Scope of delivery

All transfer units are delivered with

- Fixing screws
- Compressed air fittings

In the case of the 180° transfer unit the protective plates are delivered not fitted to the unit.

i

The following accessories are not part of the normal scope of delivery:

Control system (STEIN Automation option)

Stopper and stop parts (STEIN Automation option)

Installation kit (STEIN Automation option)

i

Through the installation of:

Stopping device,

P accessories and the corresponding

Installation kit

the transfer unit attains its full functional capability.

Fig. 4-1:
Sample
Basic configurations:

- 1 A-basic configuration
with 90° transfer unit
- 2 B-basic configuration
with 180° transfer unit

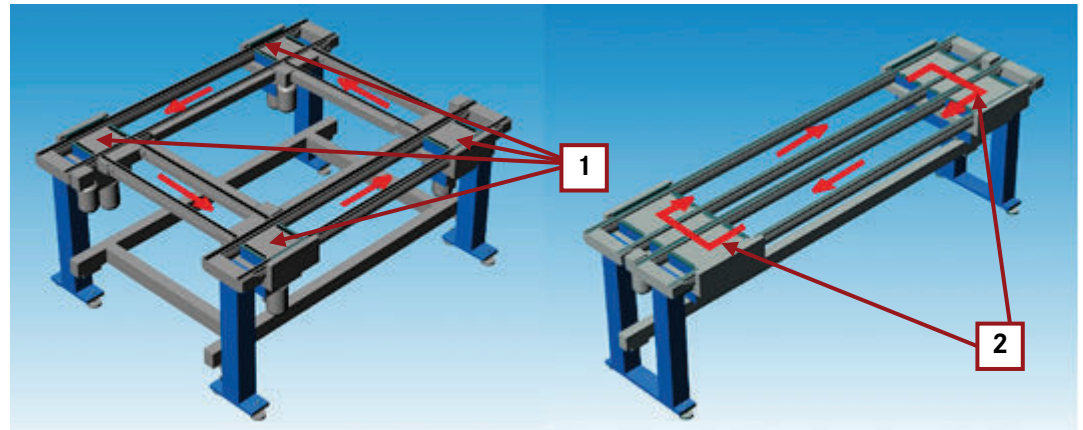

A-basic configurations are equipped with 90° transfer units.

B-basic configurations are equipped with 180° transfer units.

Transfer unit 90°

The 90° transfer unit puts the WT from the main section onto the transverse section or from the transverse section onto the main section. The 90° transfer unit is fitted between the guide profiles of the conveyor.

Transfer unit 180°

The transfer unit 180° moves the workpiece carrier to a section that runs parallel to the original direction of transport.

Procedure:

The WT is transported by the two transport belts until it reaches the inlet stopping device (STEIN Automation option) or the internal stop (standard). The proximity switch located in this position activates the elevating cylinder and the workpiece carrier is lifted up. In the last step the WT is transferred to the transverse section.



WARNING

The transfer unit may only be operated with or while enclosed by protective guards.

4.2 WT orientation

Fig. 4-2:
WT orientation with:
- Transfer unit 90°

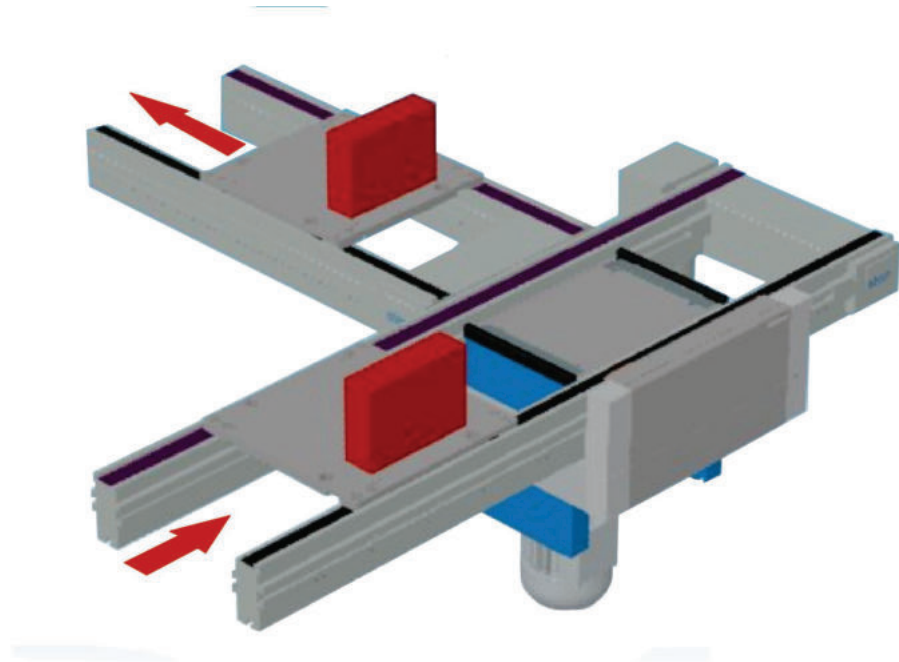

i

Please note:

The orientation of the WT is changed by means of the transfer.

Fig. 4-3:
WT orientation with:
- Transfer unit 180°

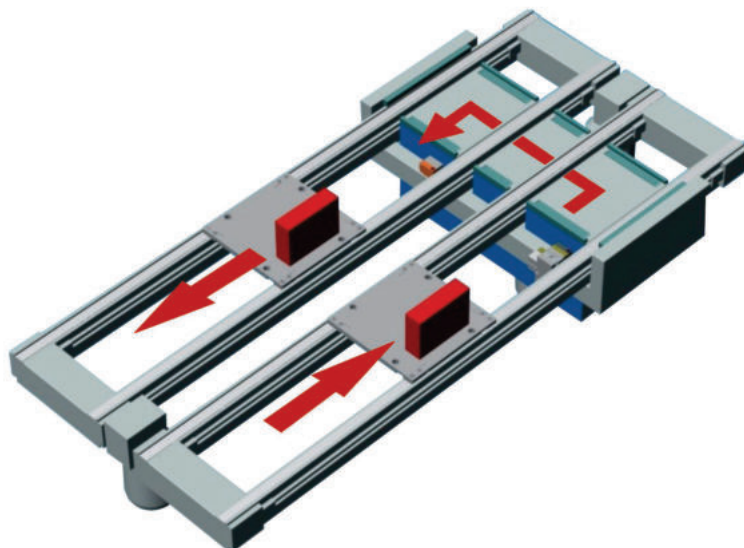

i

The outside of the workpiece becomes the inside after the 180° change of direction.

4.3 System components

Transfer unit 90°

The transfer unit 90° consists of:

Fig. 4-4:
Transfer unit 90°

- 1 Guide
- 2 Cover plate
- 3 Retaining plates
- 4 Lifting device
- 5 Drive motor (example variant)
- 6 Driving belt

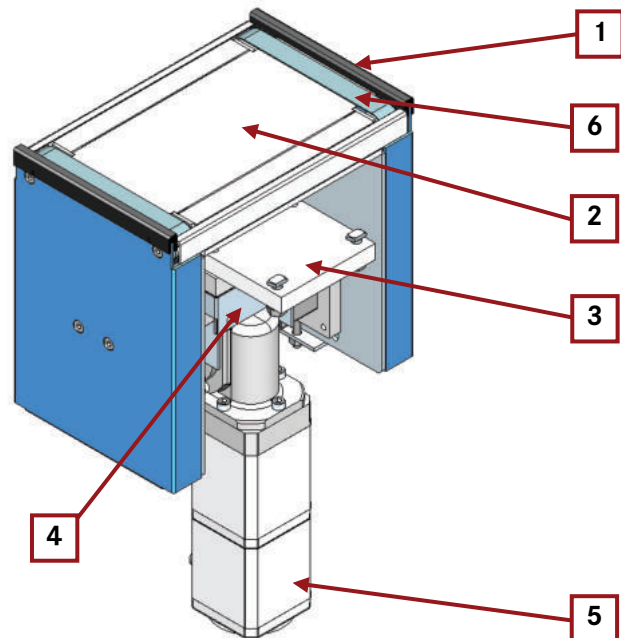

Transfer unit 180°

The transfer unit 180° places the WT onto a parallel-running section.

The transfer unit 180° comes in two models:

i

Transfer unit U180K (small) for WT with a side length ≥ 280 mm
Transfer unit U180G (large) for WT with a side length > 280 mm

The transfer unit **U180K** consists of:

Fig. 4-5:
Transfer unit U180K

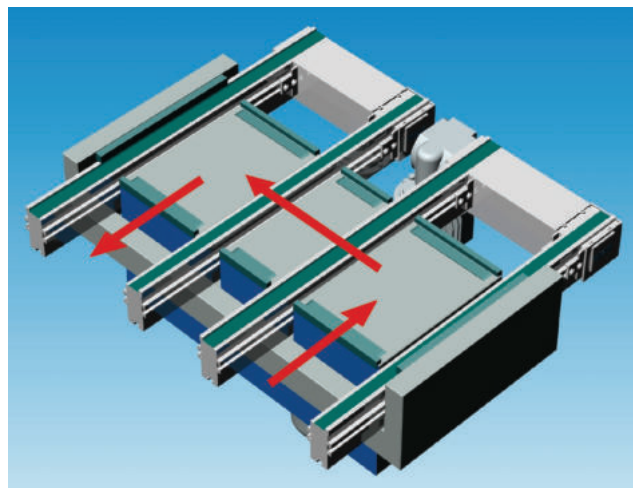
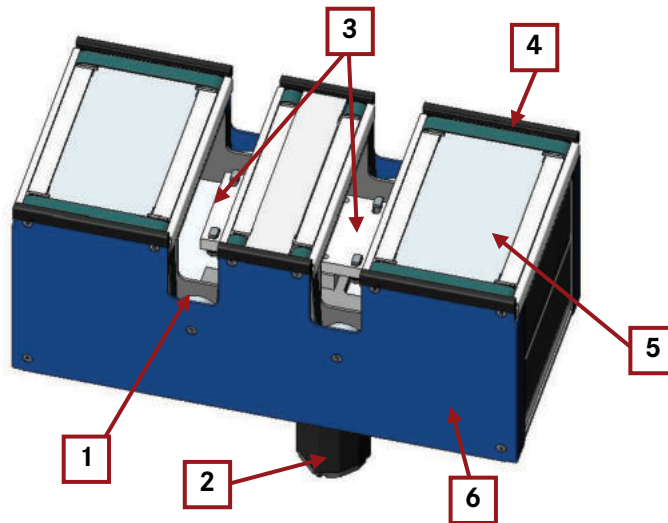

Fig. 4-6:
Transfer unit U180K

- 1 Lifting device
- 2 Drive motor (example variant)
- 3 Retaining plate
- 4 Guide
- 5 Cover plate
- 6 Cover



The transfer unit U180G consists of two 90° transfer units and additionally a WT guide (between the two conveyors).

Fig. 4-7:
Transfer unit U180G

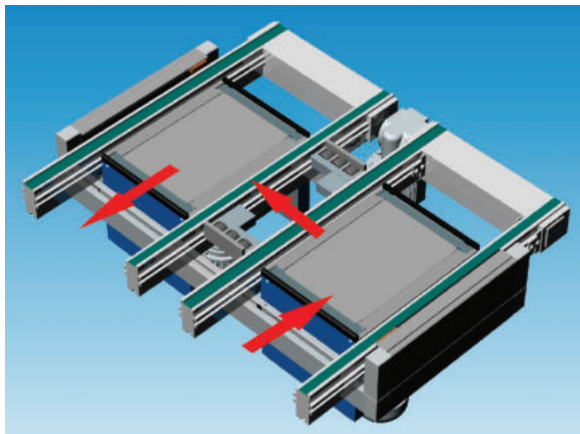
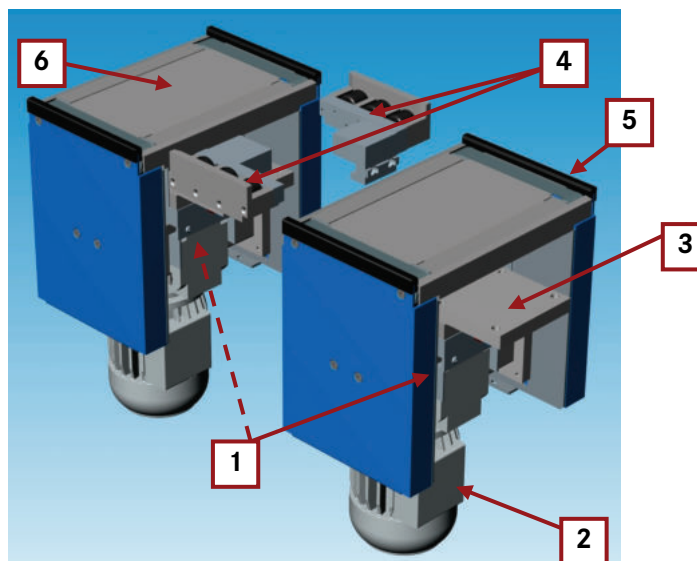

Fig. 4-8:
Transfer unit U180G

- 1 Lifting device
- 2 Drive motor
- 3 Retaining plate
- 4 WT guide (non-powered rollers)
- 5 Guide
- 6 Cover plate



5 Installing the transfer unit



When installing and assembling the transfer unit, please note the following requirements.



DANGER

The transfer unit must be integrated in the EMERGENCY STOP circuit of the higher level system controller.

5.1 Procedure

The installation procedure is divided into 7 phases:

- Preparation,
- Transfer unit installation,
- Stoppers installation,
- Connection of the transfer unit to the mains supply,
- Connection of the transfer unit to the compressed air supply,
- Connection of the stoppers,
- Fitting the safety equipment.



WARNING

For machining stations that generate shavings (for example drilling or thread-cutting machinery), covers should be installed to prevent shavings or coolant from getting into the transfer unit or the drive motor!



Further information is available from STEIN Automation.

5.2 Preparation



DANGER

In the area of the transfer unit due to an unexpected start up!



DANGER

HIGH ELECTRICAL VOLTAGE!
Electric shock hazard!

- 1 Before carrying out any installation or repair work, disconnect the relevant STEIN system from its electrical power supply.
- 2 Disconnect the STEIN system from its compressed air supply.
- 3 Put up warning signs to prevent the STEIN system from being started up while installation and repair work is being done.
- 4 Remove the workpiece carriers from the conveyors affected by the installation.

5.3 Installing the transfer unit



Protective clothing must be worn!

Wear your personal safety clothing:
Safety footwear and safety gloves.



CAUTION

Bear in mind that the transfer unit is very heavy.
Use suitable equipment, such as a fork-lift truck, to transport and install the transfer unit.

Fig. 5-1:
Installation example:
Transfer unit 90°

- 1 Compressed air connections (covered)
- 2 Power connection

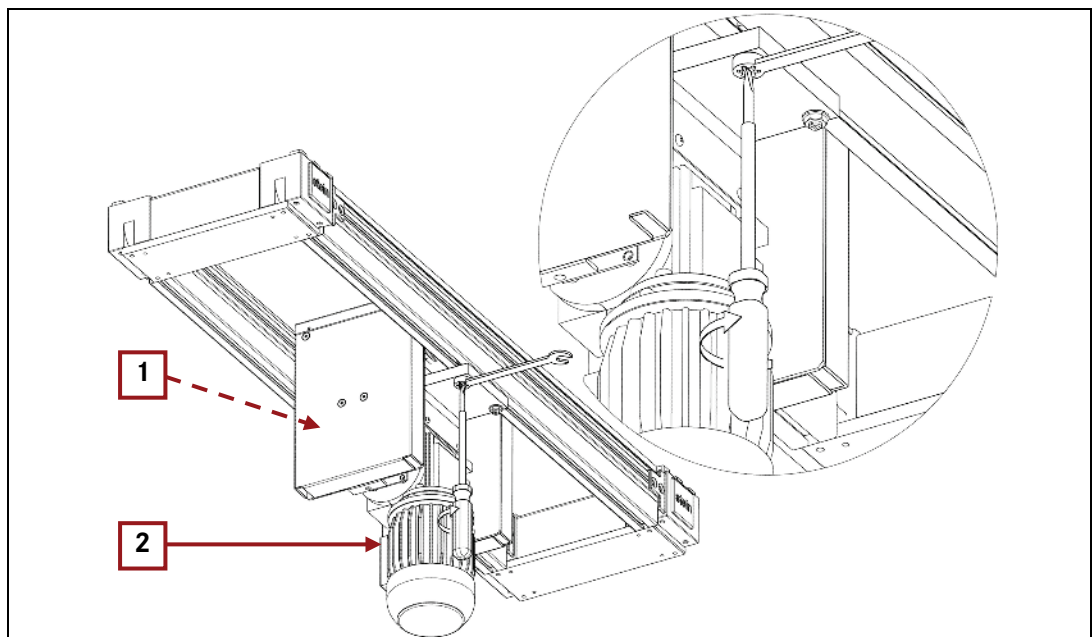
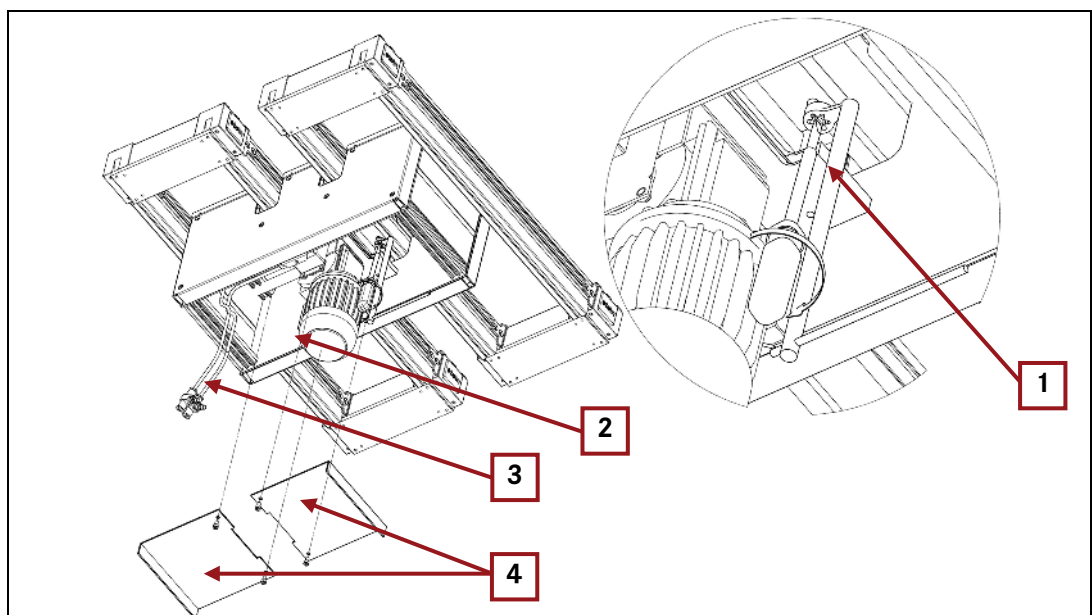

Fig. 5-2:
Installation example:
180° transfer unit K

- 1 Special wrench
- 2 Power connection
- 3 Compressed air connections
- 4 Protective plates





CAUTION

After installing the 180° transfer unit you must also install the supplied protective plates!



CAUTION

Do not place the 180° transfer unit in service without the installation kit!

i

To install the 180° transfer unit use the special offset wrench from Stein Automation.

i

Prior to installing the 90° transfer unit the transverse section braces must be mounted.

i

Through the installation of:

- Stoppers
- P accessories and the corresponding
- Installation kit

the transfer unit attains its full functional capability.

- Align the slots of the slotted screws parallel to the belt profile. The slotted screws are now unlocked.
- Guide the transfer unit from below vertically between the belt profiles.
- Secure the transfer unit from falling with suitable aids or with additional assisting personnel.
- Position the transfer unit correctly.
- Rotate the slotted screw by 90° to the belt profile with the screwdriver. The slotted screws are now locked.
- Tighten the locknuts of the slotted screws.

i

In order to ensure correct functioning, all the directly bordering switches and stoppers must be correctly adjusted.

i

Please refer to chapter 10 for the installation dimensions and other dimensions.

5.4 Fitting the stopping devices

i

Further information can be found in the technical description “Stopping Device” (SE).

Please also see the service video “Replacing the stopper”.

5.5 Connecting the transfer unit to the mains supply



DANGER

HIGH ELECTRICAL VOLTAGE!

Electric shock hazard!

Only qualified electricians may connect the system to the mains supply!

Be sure to use only approved plug-in systems when connecting to the power supply.

Please contact STEIN Automation if you have any questions.



CAUTION

Route the connecting cable in the cable ducts provided in the STEIN transport system.



To ensure that the transfer unit works properly, the power cable length must be at least as long as the lifting path length.

For details of the electrical connections of the transfer unit please refer to the STEIN SoftMove operating instructions.

5.6 Connecting the transfer unit to the compressed air supply



WARNING

Only specialised STEIN Automation personnel should carry out the connection to the compressed air supply!

Carry out installation work only in a pressureless state!

Carry out adjustment and setting work only while the safety fittings are mounted!



CAUTION

Route the connecting cable in the cable ducts provided in the STEIN transport system.



ATTENTION

Observe the following operating pressures:

- Maximum operating pressure: 6 bar
- STEIN operating pressure: 4 bar

i

Festo GRLA-1/8-QS6 throttle check valves are used as connectors.

Type PUN-S hoses with an exterior diameter of 6 mm and wall thickness of 1 mm are used, manufactured by: Festo.

Fig. 5-3:
Connect the transfer unit to the compressed air supply

- 1 Compressed air connections

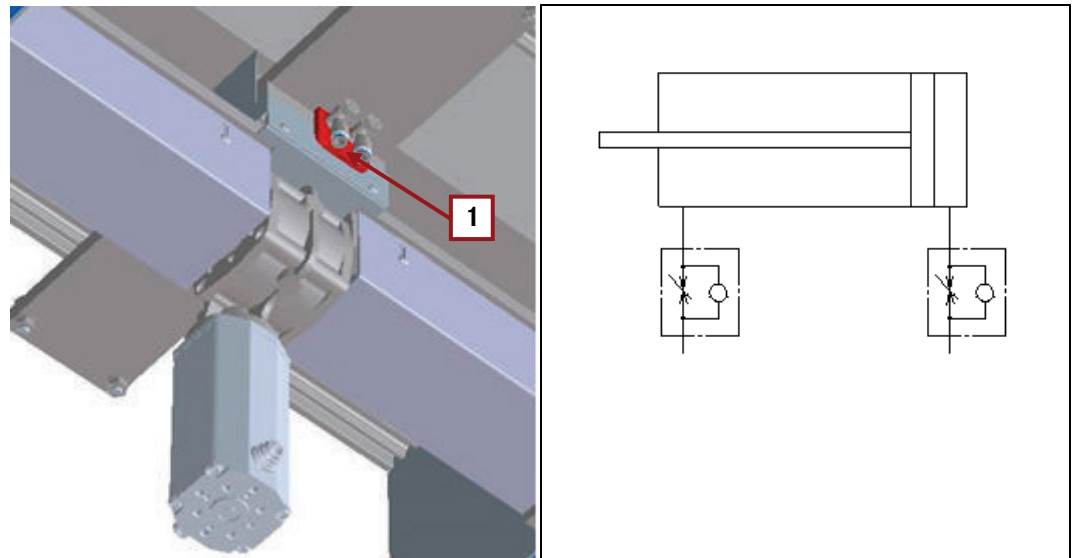

- Connect the transfer unit to the compressed air supply using the two connections "S" and "B".
- Adjust the throttle check valves so that there is no uncontrolled rapid lifting movement.

i

Connect "S" (black): Cylinder moves up.
Connect "B" (blue): Cylinder moves down.

5.7 Connecting the stoppers



Further information can be found in the technical description “Stopping Device” (SE).

5.8 Installing safety equipment



WARNING

The system operator is obliged to operate the transfer unit only with mounted protective guards.

- Install the protective guards in a functional way.

6 Initial operation

Carry out the following checks before initial operation:

- Are all the electric and pneumatic leads and hoses undamaged?
- Are all the electric and pneumatic leads / hoses correctly connected?
- Have all the mechanical components been tightly fastened in place?
- Have all tools and other equipment been cleared from the transport area?
- Has all safety equipment been installed and is it working correctly?



WARNING

No WTs may be on the transfer unit when the system is being switched on.

The transfer unit makes a very rapid lifting movement when it is switched on. This could catapult WTs from the transfer unit or they could fall off the conveyor.

Once you have carried out all these checks, you can continue with the initial operation.

- Switch on the Transport System and its associated processing stations and carry out a trial run.
- Check the functions of the individual elements and processing stations as well as the proper (programmed) interaction of the complete system.
- Check that the safety equipment is functioning correctly!



WARNING

Only allow the Transport System to be used for production once you have carried out a successful test run.

7 Transfer unit operation

i

The WTS control system programme must be correctly modified to ensure the proper operation of the transfer unit.

In normal operation the transfer unit is controlled by the STEIN plant control system.

Please contact STEIN Automation if you have any questions.

Example Fig. 7-1:
90° transfer unit

- 1 Stopping device
- 2 Transfer unit transport belt
- 3 Belt profile
- 4 ASI module with valves and switches, bottom
- 5 Stop interior
- 6 Installation kit with external stop
- 7 Exterior switch

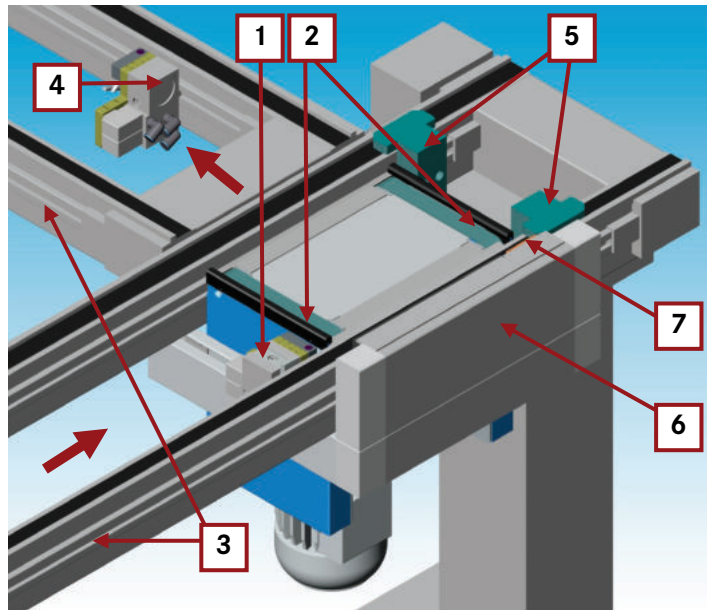

Transferring a WT with the 90° transfer unit:

- The conveyor transports the WT up to the “internal stop”(5). The stopper (1) stops the next WT. The switch (7) is attenuated.
- The switch (7) triggers the lifting movement of the transfer unit via the Stein controller, which then lifts itself up and picks up the WT with the transport belts and transports it to the transverse section.
- The WT continues on the transverse section. In doing so, it attenuates the switch in the ASI module (4).
- The ASI module (4) lowers the stopper latch in the stopper (1) via the Stein controller and thus releases the next WT.



WARNING

The transfer unit may only be operated with or while enclosed by protective guards.

Fig. 7-2:
180° transfer unit

- 1 Stopping device
- 2 Transfer unit transport belt
- 3 Belt profile
- 4 ASi module with valves and switches, bottom
- 5 Stop interior
- 6 Installation kit with external stop
- 7 Exterior switch
- 8 Exterior switch

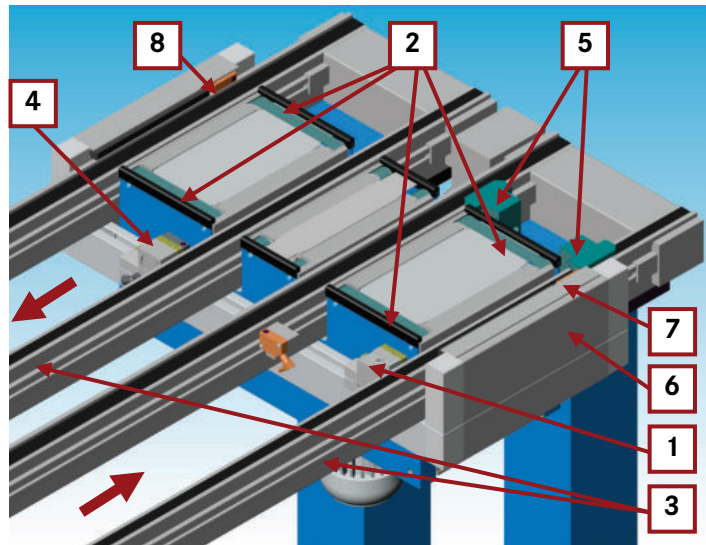

Transferring a WT with the 180° transfer unit:

- The conveyor transports the WT up to the “internal stop” (5). The stopper (1) stops the next WT. The switch (7) is attenuated.
- The switch (7) triggers the lifting movement of the transfer unit via the Stein controller. If the WT is picked up by the transport belts, the WT is transported up to the external stop. The switch (8) is attenuated.
- The switch (8) triggers the lowering movement of the transfer unit via the Stein controller. The WT is placed on the parallel conveyor.
- The switch in the ASI module (4) is attenuated when the WT is transported by the conveyor.
- The switch in the ASI module releases the next WT for onward transport.



WARNING

The transfer unit may only be operated with or while enclosed by protective guards.

8 Faults



WARNING

It is not permitted to repair damaged and / or defective parts.
Get in touch with STEIN Automation.
The service address can be found on page 2.

8.1 Troubleshooting problems

Problem	Cause	Solution
Transfer unit belts are not running	<p>Motor not connected to the power supply</p> <p>Plug connection wiring wrong</p> <p>Possibly plug connection wiring of extension cable wrong</p>	<p><input type="checkbox"/> Correctly connect the power supply cable of the modules (should only be performed by a specialist)</p> <p><input type="checkbox"/> Correct the plug connection wiring (must be done by a qualified electrician)</p> <p><input type="checkbox"/> Correct the plug connection wiring of the extension cable (must be done by a qualified electrician)</p>
Compressed air supply fails	Faulty valve.	Replace valve.
	Compressed air supply cut.	Restore compressed air supply.
No lift movement	WTS transport system control failure.	Activate the control system.
	Processing station control system failure.	
	Bad contact between plug and socket.	Firmly insert plug into socket.
	Transfer unit incorrectly installed.	Check and if necessary adjust position and screws.
Transfer unit lifts too soon / too late	Position switch incorrectly set.	Re-set position switch.



In the event of faults, a message will be displayed on the allocated slave - Exx

A list of fault messages can be found in Appendix 6-1 of the system documentation for the Workpiece Transport System and in the system documentation in the main control cabinet.

9 Cleaning, inspection, maintenance

9.1 Cleaning

Depending on the ambient conditions of the transport system, the transfer unit gets dirty.

Clean the transfer unit regularly! How frequently to do this depends on how dirty it gets. STEIN Automation recommends cleaning the transfer unit once a week.

i

Cleaning does not mean the transfer unit needs to be dismantled.



DANGER

In the area of the transfer unit due to an unexpected start up!



DANGER

**HIGH ELECTRICAL VOLTAGE!
Electric shock hazard!**

- 1 Before carrying out any installation or repair work, disconnect the relevant Workpiece Transport System from its electrical power supply.
- 2 Disconnect the Workpiece Transport System from its compressed air supply.
- 3 Put up warning signs to prevent the system being started up while installation and repair work is being done.
- 4 Remove any workpiece carriers located on the affected conveyors.



Protective clothing must be worn!

- When cleaning, wear goggles, safety gloves and a dust mask.
- Only use a vacuum cleaner to remove dust, shavings and other particles.
- Remove dust, shavings and other particles with a vacuum cleaner.



ATTENTION

When cleaning, do not use any harsh, combustible or scouring cleaning fluids / cleaning materials.

Prevent fluid from getting into the components of the system!

i

STEIN Automation recommends Industrie Clean manufactured by Würth, product number: 893140 or Arecal Clean by RECA Norm, product number: 0895014500.

- Clean the top and bottom of the belts, the drive and deflector rollers of all fouling and lubricants.
- Clean the surfaces with a soft, lint free cloth, lightly dampened with cleaning fluid.



Environmental protection

Dispose of waste material and used cleaning cloths in an environmentally responsible way.

9.2 Inspection

Interval	Component	Inspection criterion	Solution
Semi-annually	Transport belt	<ul style="list-style-type: none"> • Wear and abrasion, • Dirt, • Condition of the bonding point, • Correct running, • Running noises 	<input type="checkbox"/> Clean or, if applicable, replace transport belt
Annually	Motor power supply plug	<ul style="list-style-type: none"> • Stable connections 	<input type="checkbox"/> Fit on the plug connection so that it is firmly seated
	Pneumatic connection	<ul style="list-style-type: none"> • Stable connections 	<input type="checkbox"/> Fit on the plug connection so that it is firmly seated
	Transfer unit overall	<ul style="list-style-type: none"> • Play, • operational precision 	<input type="checkbox"/> Re-tighten loose screw connections



For further information on transport belts, please refer to the STEIN Automation Service video "Belt change".

9.3 Maintenance



ATTENTION

When carrying out the necessary maintenance work, observe the following:

- Spare parts must satisfy the technical requirements set out by the manufacturer. Use original spare parts.
- Carry out the installation with care and in accordance with the regulations of STEIN Automation.
- Use nuts and bolts of the prescribed screw quality and tighten them with the prescribed tightening torques.
- Check the screw connections regularly.



- Please contact STEIN Automation if you have any questions.

10 Dimension sheet

Fig. 10-1:
Dimension sheet
Transfer unit 90°
Soft Move
with installation kit

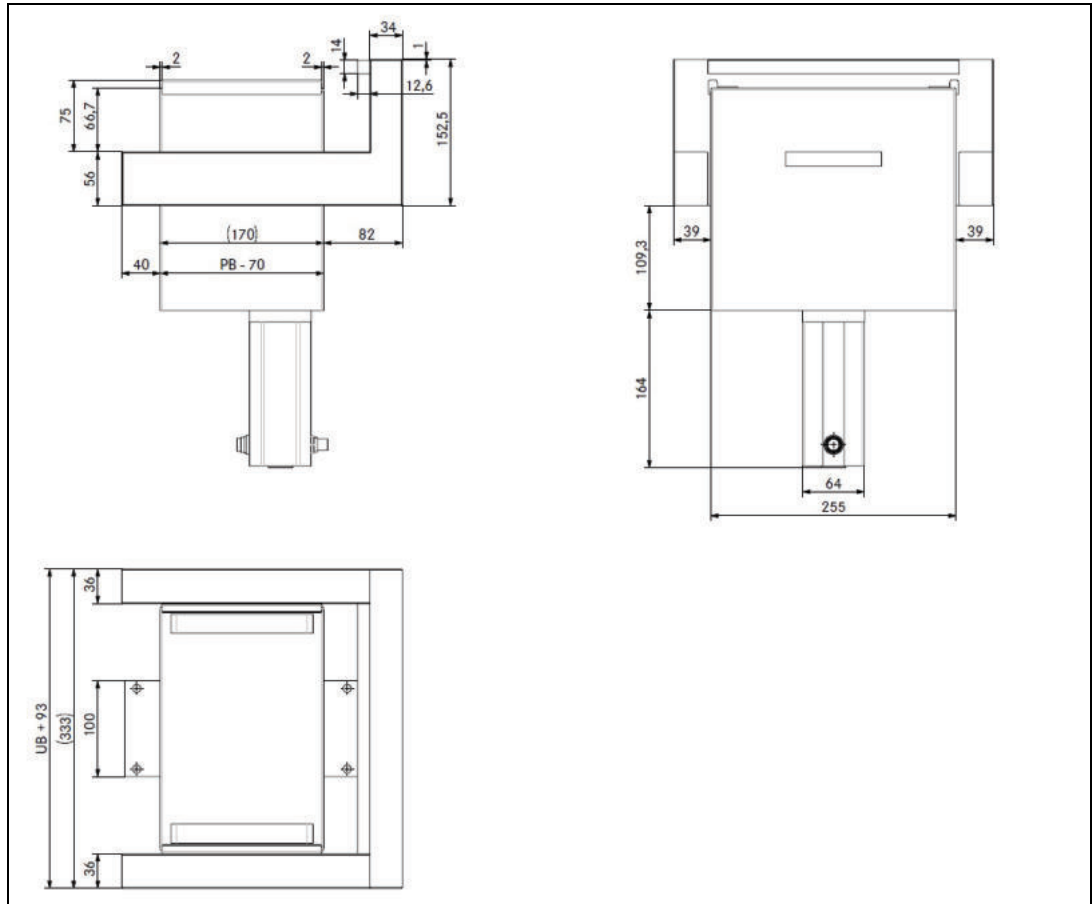

Fig. 10-2:
Dimension sheet
Transfer unit 90°
Soft Move
PB/UB > 400mm

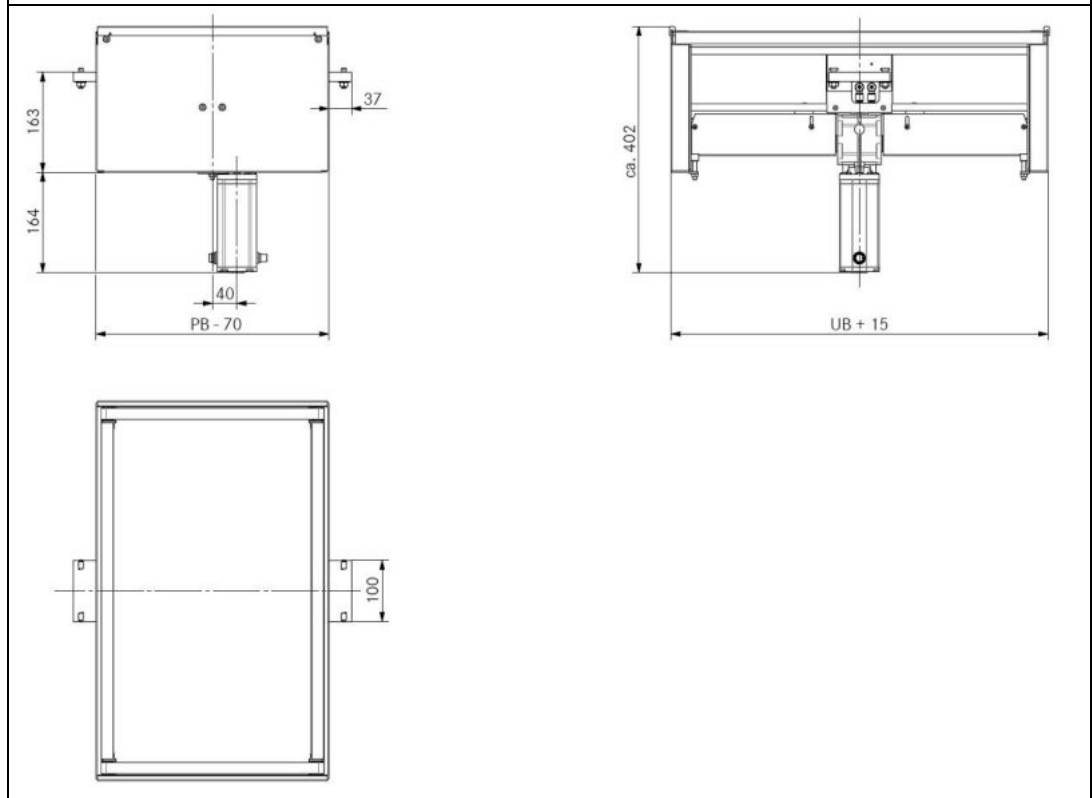
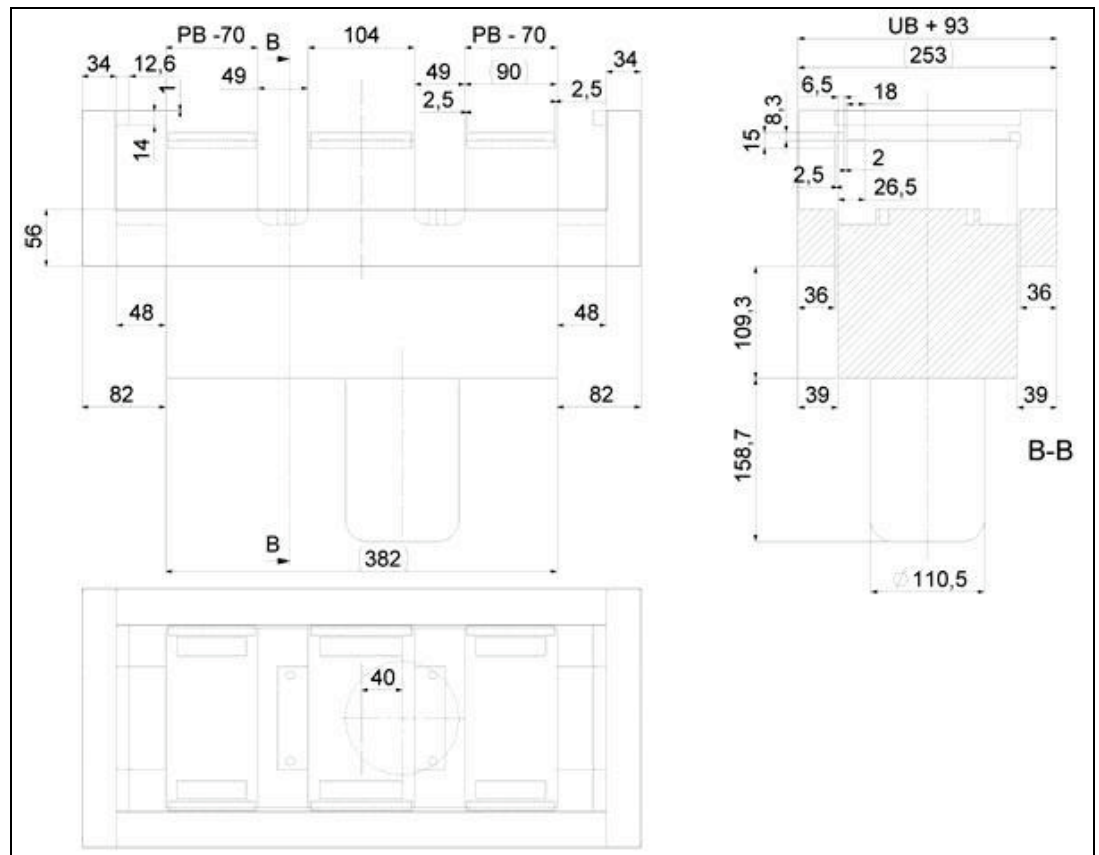

Fig. 10-3:
Dimension sheet
Transfer unit 180°
PB <280mm
Soft Move
with installation kit



11 Spare parts

11.1 300 916 001 Transfer unit 90° - PB160-200 / UB160-400

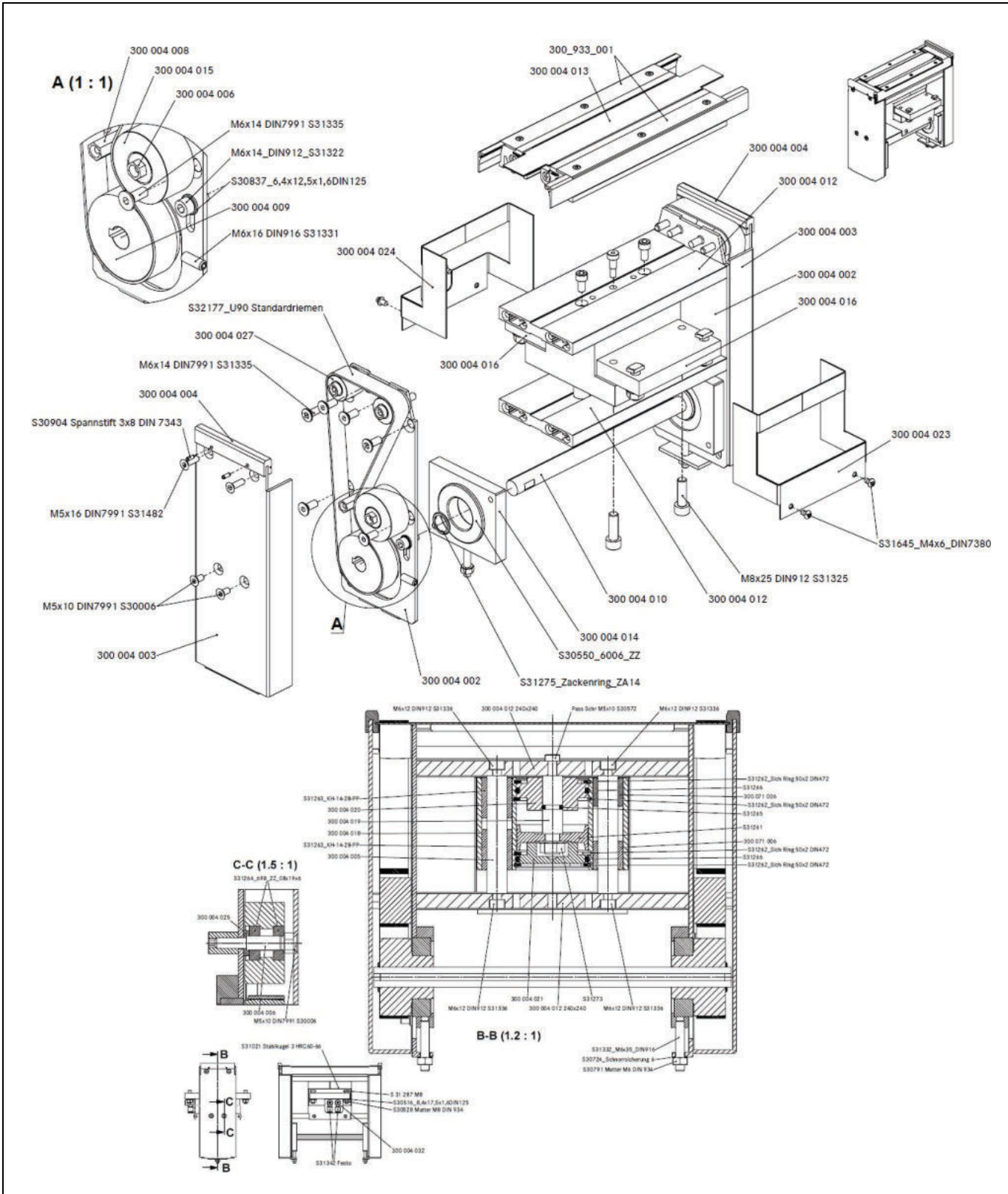

Fig. 11-1: Transfer unit 90° - 300 916 001 – PB160–200 / UB160–400

Quantity	Order number	Description
2	300 004 002	Side part 90°
2	300 004 003	Cover 90°
2	300 004 004	Guide
2	300 004 005	Guide shaft
2	300 004 006	Screw
2	300 004 008	Spacer bolt
2	300 004 009	Drive wheel
1	300 004 010	Drive shaft
2	300 004 012	Stiffener
1	300 004 013	Cover plate
2	300 004 014	Bearing plate
2	300 004 015	Deflector roller
2	300 004 016	Retaining plate
1	300 004 018	Cylinder casing
1	300 004 019	Piston rod
1	300 004 020	Piston guide
1	300 004 021	Cylinder cover
1	300 004 023	Cover
1	300 004 024	Cover
2	300 004 025	Washer
4	300 004 027	Wheel roller
1	300 004 032	Cover
2	300 071 006	Socket
2	300 933 001	Edge trim conversion kit for U90/U180
1	S31021	Ball d = 3mm
4	S30904	Dowel pin 3x8 DIN7343
4	S31645	Screw M4x6 3M coated DIN7380
4	S30006	Screw M5x10 galv. DIN7991
1	S30572	Dowel screw M5x10
4	S31482	Countersunk screw M5x16 DIN7991
4	S31336	Screw M6x12 3M coated DIN912
4	S31322	Screw M6x14 3M coated DIN912
12	S31335	Countersunk screw M6x14 DIN7991
2	S31331	Screw M6x16 3M coated DIN916
2	S31332	Screw M6x35 3M coated DIN916
2	S30791	Screw nut M6 DIN934
4	S30837	Washer B 6.4 DIN125
2	S30724	Schnorr safety washer M6
4	S31325	Screw M8x25 3M coated DIN912
4	S31287	T-slotted screw M8
4	S30516	Washer B 8.4 galvanised DIN125 St
4	S30528	Screw nut M8 DIN934
1	S31265	O-ring 9x2.5
1	S31273	Lock nut M10
2	S31275	Notched ring ZA 14
1	S31261	KPK 15x10x18N
2	S31266	O-ring 44x3
4	S31262	Retaining ring 50x2 DIN472
2	S31263	Ball bushing KH 1428 P
2	S30550	Groove ball bearing 6006 2 Z
4	S31264	Groove ball bearing 698 2 Z
2	S31342	Throttle check valve GRLA 1/8QS6, Festo no.13327
2	S32177	Belts for all standard U90

11.2 300 917 001 Transfer unit 90° - PB200-400 / UB to 400

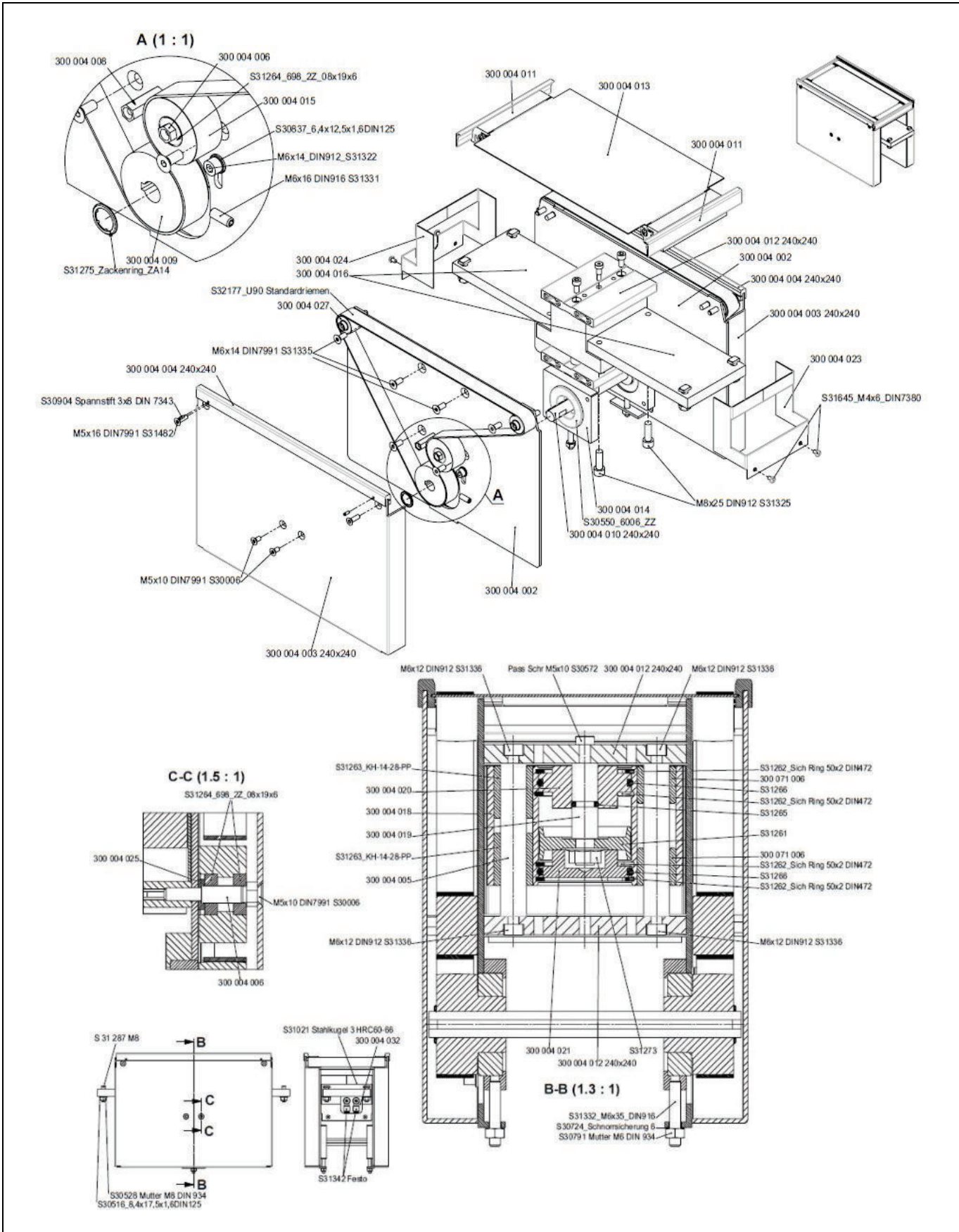

Fig. 11-2: Transfer unit 90° - 300 917 001 – PB200-400 / UB to 400

Quantity	Order number	Description
2	300 004 002	Side part 90°
2	300 004 003	Cover 90°
2	300 004 004	Guide
2	300 004 005	Guide shaft
2	300 004 006	Screw
2	300 004 008	Spacer bolt
2	300 004 009	Drive wheel
1	300 004 010	Drive shaft
2	300 004 011	Skirt
2	300 004 012	Stiffener
1	300 004 013	Cover plate
2	300 004 014	Bearing plate
2	300 004 015	Deflector roller
2	300 004 016	Retaining plate
1	300 004 018	Cylinder casing
1	300 004 019	Piston rod
1	300 004 020	Piston guide
1	300 004 021	Cylinder cover
1	300 004 023	Cover
1	300 004 024	Cover
2	300 004 025	Washer
4	300 004 027	Wheel roller
1	300 004 032	Cover
2	300 071 006	Socket
1	S31021	Ball d = 3mm
4	S30904	Dowel pin 3x8 DIN7343
4	S31645	Screw M4x6 3M coated DIN7380
4	S30006	Screw M5x10 galv. DIN7991
1	S30572	Dowel screw M5x10
4	S31482	Countersunk screw M5x16 DIN7991
4	S31336	Screw M6x12 3M coated DIN912
4	S31322	Screw M6x14 3M coated DIN912
12	S31335	Countersunk screw M6x14 DIN7991
2	S31331	Screw M6x16 3M coated DIN916
2	S31332	Screw M6x35 3M coated DIN916
2	S30791	Screw nut M6 DIN934
4	S30837	Washer B 6.4 DIN125
2	S30724	Schnorr safety washer M6
4	S31325	Screw M8x25 3M coated DIN912
4	S31287	T-slotted screw M8
4	S30516	Washer B 8.4 galvanised DIN125 St
4	S30528	Screw nut M8 DIN934
1	S31265	O-ring 9x2.5
1	S31273	Lock nut M10
2	S31275	Notched ring ZA 14
1	S31261	KPK 15x10x18N
2	S31266	O-ring 44x3
4	S31262	Retaining ring 50x2 DIN472
2	S31263	Ball bushing KH 1428 P
2	S30550	Groove ball bearing 6006 2 Z
4	S31264	Groove ball bearing 698 2 Z
2	S32177	Belts for all standard U90
2	S31342	Throttle check valve GRLA 1/8QS6, Festo no.13327

11.3 300 918 001 Transfer unit 90° - PB200-400 / UB > 400

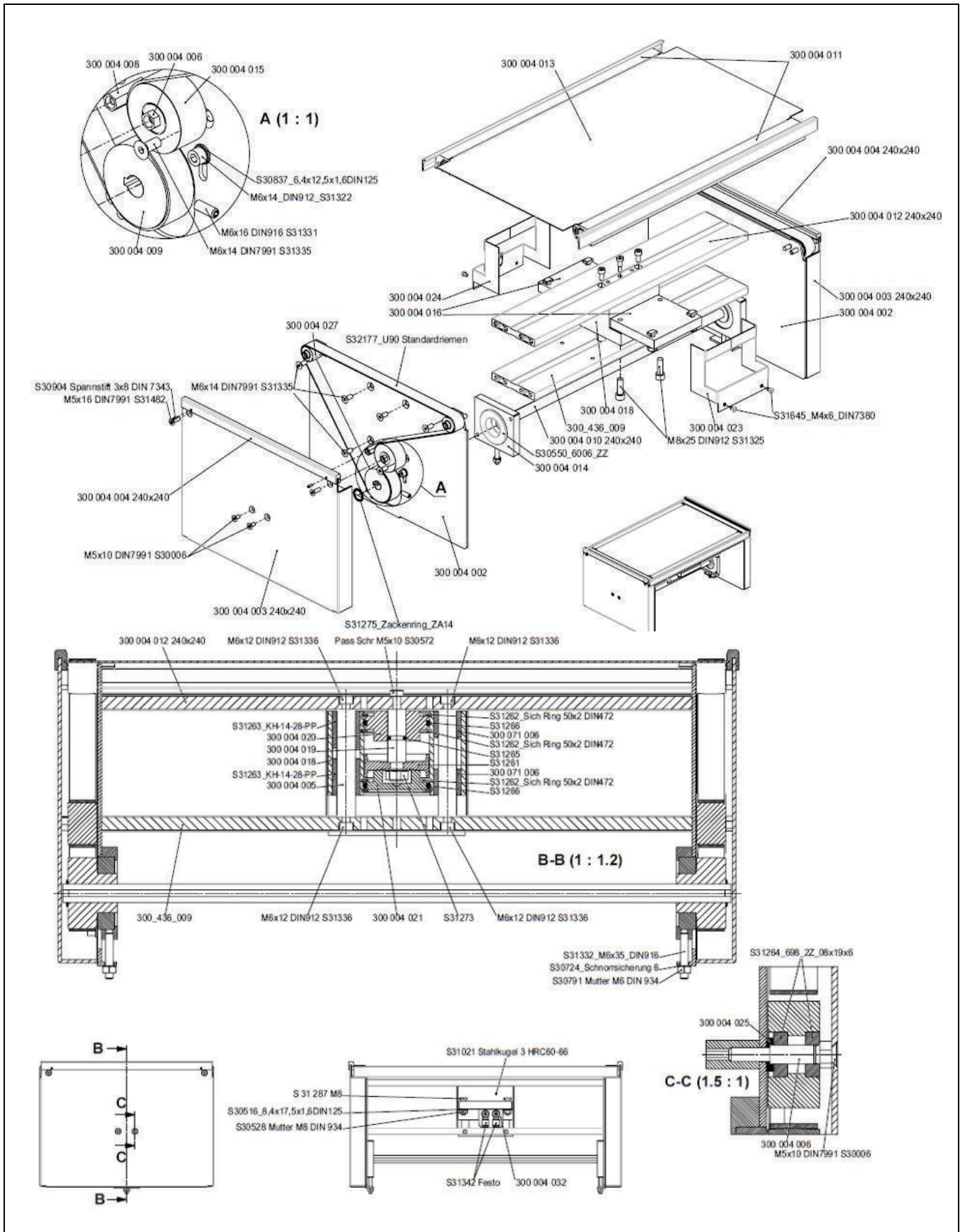

Fig. 11-3: Transfer unit 90° - 300 918 001 – PB200-400 / UB >400

Quantity	Order number	Description
2	300 004 002	Side panel
2	300 004 003	Cover
2	300 004 004	Guide
2	300 004 005	Guide shaft
2	300 004 006	Screw
2	300 004 008	Spacer bolt
2	300 004 009	Drive wheel
1	300 004 010	Drive shaft
2	300 004 011	Skirt for U90 and U180
1	300 004 012	Stiffener
1	300 004 013	Cover plate
2	300 004 014	Bearing plate
2	300 004 015	Deflector roller
2	300 004 016	Retaining plate
1	300 004 018	Cylinder casing
1	300 004 019	Piston rod
1	300 004 020	Piston guide
1	300 004 021	Cylinder cover
1	300 004 023	Cover
1	300 004 024	Cover
2	300 004 025	Washer
4	300 004 027	Wheel roller
1	300 004 032	Cover
2	300 071 006	Socket
1	300 436 009	Stiffener
4	S30904	Dowel pin 3x8 DIN7343
1	S31021	Steel ball 3
4	S31645	M4x6 DIN7380
4	S30006	M5x10 DIN7991
1	S30572	Dowel screw M5x10
4	S31482	M5x16 DIN7991
4	S31336	M6x12 3M coated DIN912
12	S31335	M6x14 3M coated DIN7991
4	S31322	M6x14 DIN912
2	S31331	M6x16 DIN916
2	S31332	M6x35 3M coated DIN916
2	S30791	Nut M6 DIN EN 24035 (DIN439)
4	S30837	Washer B6.4 DIN125 galv.
2	S30724	Schnorr protection ring 6
4	S30528	M8 Nut DIN934
4	S30516	Washer 8.4x17.5x1 DIN125
4	S31287	T-slotted screw M8
4	S31325	M8x25 DIN912
1	S31273	Lock nut M10
1	S31265	O-ring 9x2.5
2	S31275	Notched ring ZA 14
1	S31261	KPK 15x10x18N
2	S31266	O-ring 44x3
4	S31262	Retaining ring 50x2 DIN472
2	S31263	Ball bushing
4	S31264	698 ZZ 08x19x6 DIN625-T1
2	S30550	Groove ball bearing 6006 ZZ DIN625-T1
2	S31342	Throttle check valve GRLA 1/8 QS6 Festo
2	S32177	Belt for U90

11.4 300 939 001 Transfer unit 90° - PB160-200 / UB >400

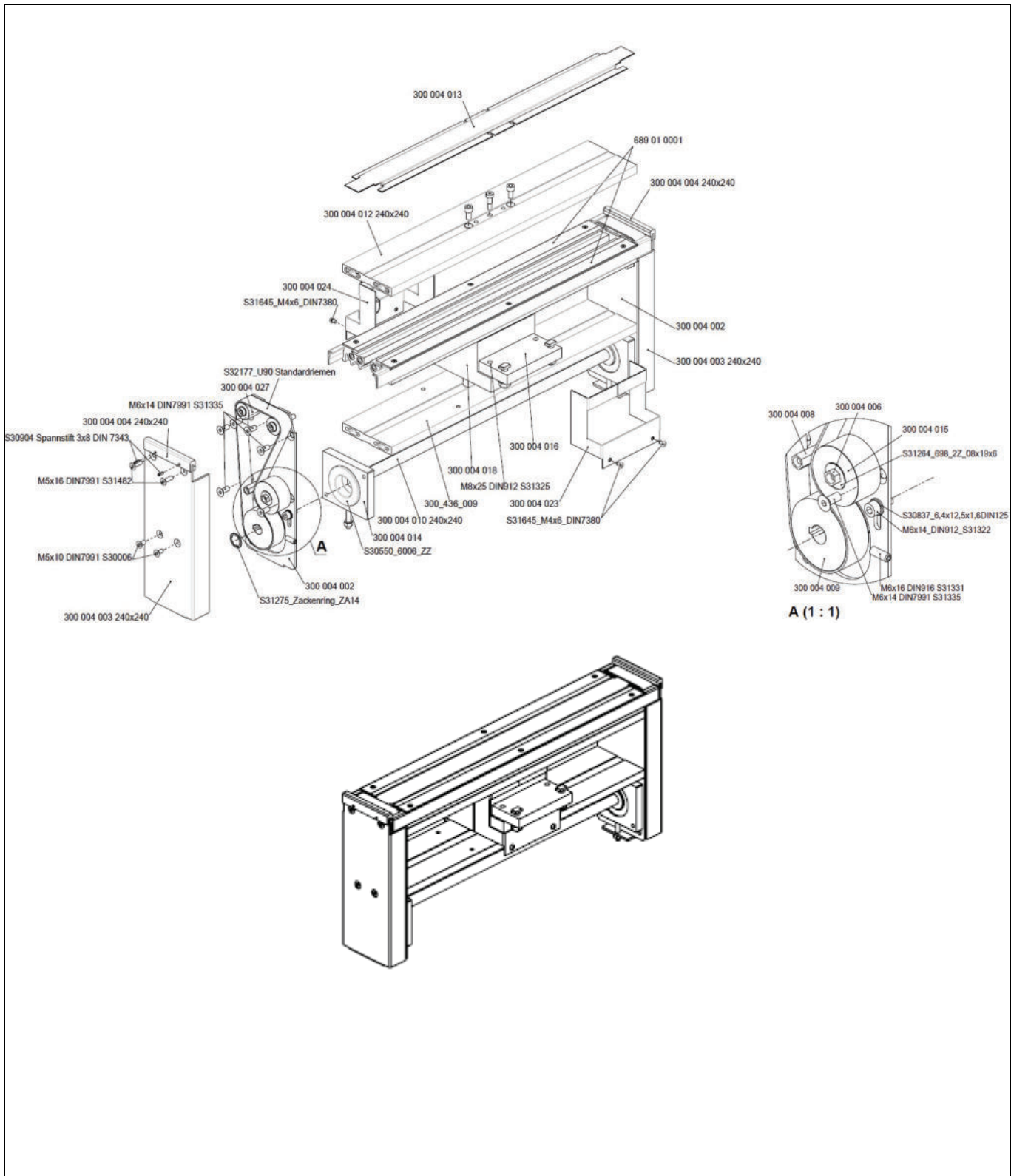

Fig. 11-4: Transfer unit 90° - 300 918 001 – PB160-200 / UB >400 - sheet 1

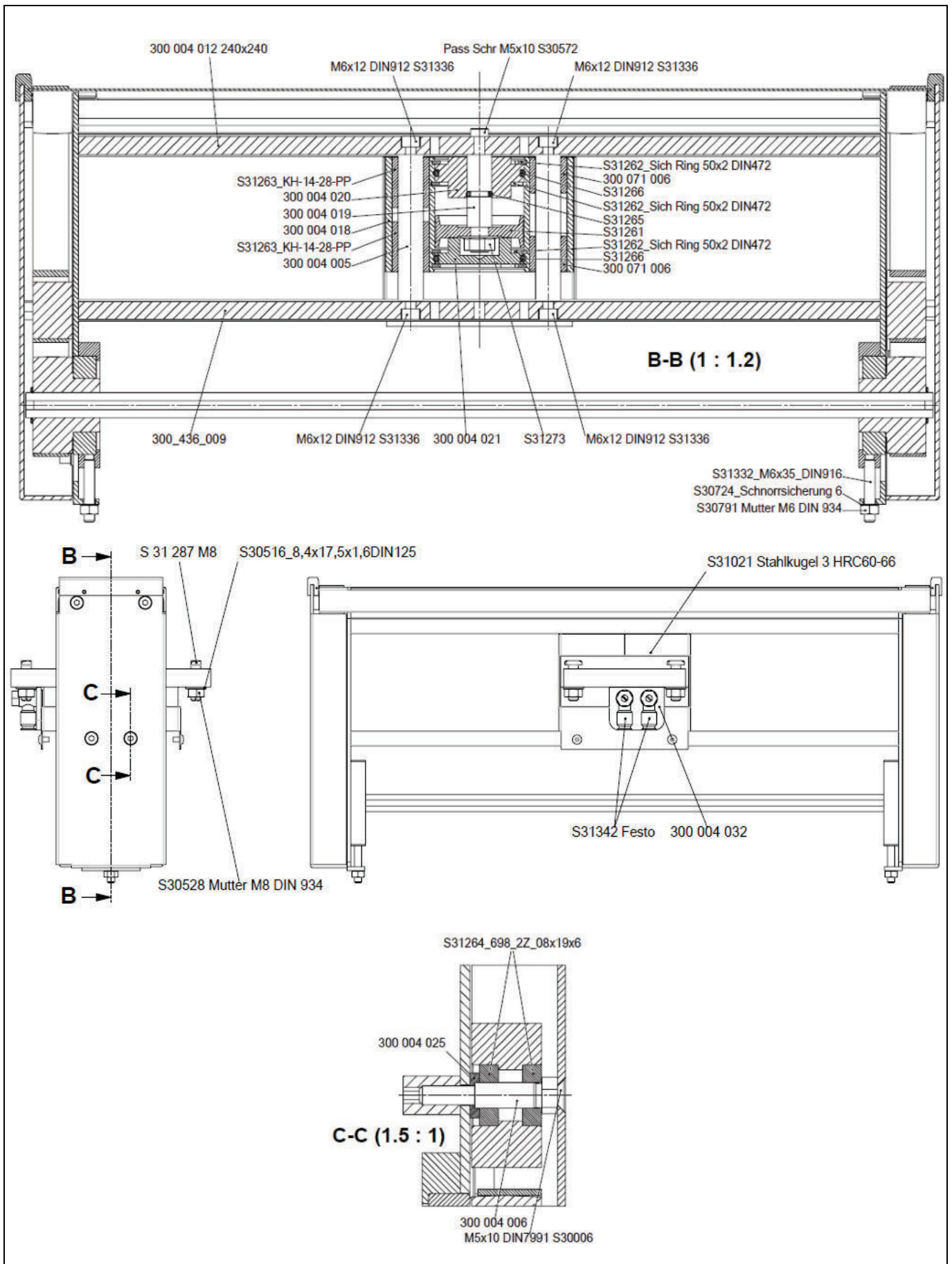

Fig. 11-5: Transfer unit 90° - 300 918 001 – PB160-200 / UB >400 - sheet 2

Quantity	Order number	Description
2	300 004 002	Side panel
2	300 004 003	Cover
2	300 004 004	Guide
2	300 004 005	Guide shaft
2	300 004 006	Screw
2	300 004 008	Spacer bolt
2	300 004 009	Drive wheel
1	300 004 010	Drive shaft
1	300 004 012	Stiffener
1	300 004 013	Cover plate
2	300 004 014	Bearing plate
2	300 004 015	Deflector roller
2	300 004 016	Retaining plate
1	300 004 018	Cylinder casing
1	300 004 019	Piston rod
1	300 004 020	Piston guide
1	300 004 021	Cylinder cover
1	300 004 023	Cover
1	300 004 024	Cover
2	300 004 025	Washer
4	300 004 027	Wheel roller
1	300 004 032	Cover
2	300 071 006	Socket
1	300 436 009	Stiffener
2	689 01 0001	Edge trim kit
4	S30904	Dowel pin 3x8 DIN7343
1	S31021	Steel ball 3
4	S31645	M4x6 DIN7380
4	S30006	M5x10 DIN7991
1	S30572	Dowel screw M5x10
4	S31482	M5x16 DIN7991
4	S31336	M6x12 3M coated DIN912
12	S31335	M6x14 3M coated DIN7991
4	S31322	M6x14 DIN912
2	S31331	M6x16 DIN916
2	S31332	M6x35 3M coated DIN916
2	S30791	Nut M6 DIN EN 24 035 (DIN439)
4	S30837	Washer B6.4 DIN 125 galv.
2	S30724	Schnorr protection ring 6
4	S30528	M8 Nut DIN934
4	S30516	Washer 8.4x17.5x1 DIN125
4	S31287	T-slotted screw M8
4	S31325	M8x25 DIN912
1	S31273	Lock nut M10
1	S31265	O-ring 9x2.5
2	S31275	Notched ring ZA14
1	S31261	KPK 15x10x18N
2	S31266	O-ring 44x3
4	S31262	Retaining ring 50x2 DIN472
2	S31263	Ball bushing
4	S31264	698 ZZ 08x19x6 DIN625-T1
2	S30550	Groove ball bearing 6006 ZZ DIN625-T1
2	S31342	Throttle check valve GRLA 1/8 QS6 Festo
2	S32177	Belt for U90

11.5 300 931 001 Attachment of two transfer units 90° (Soft Move)

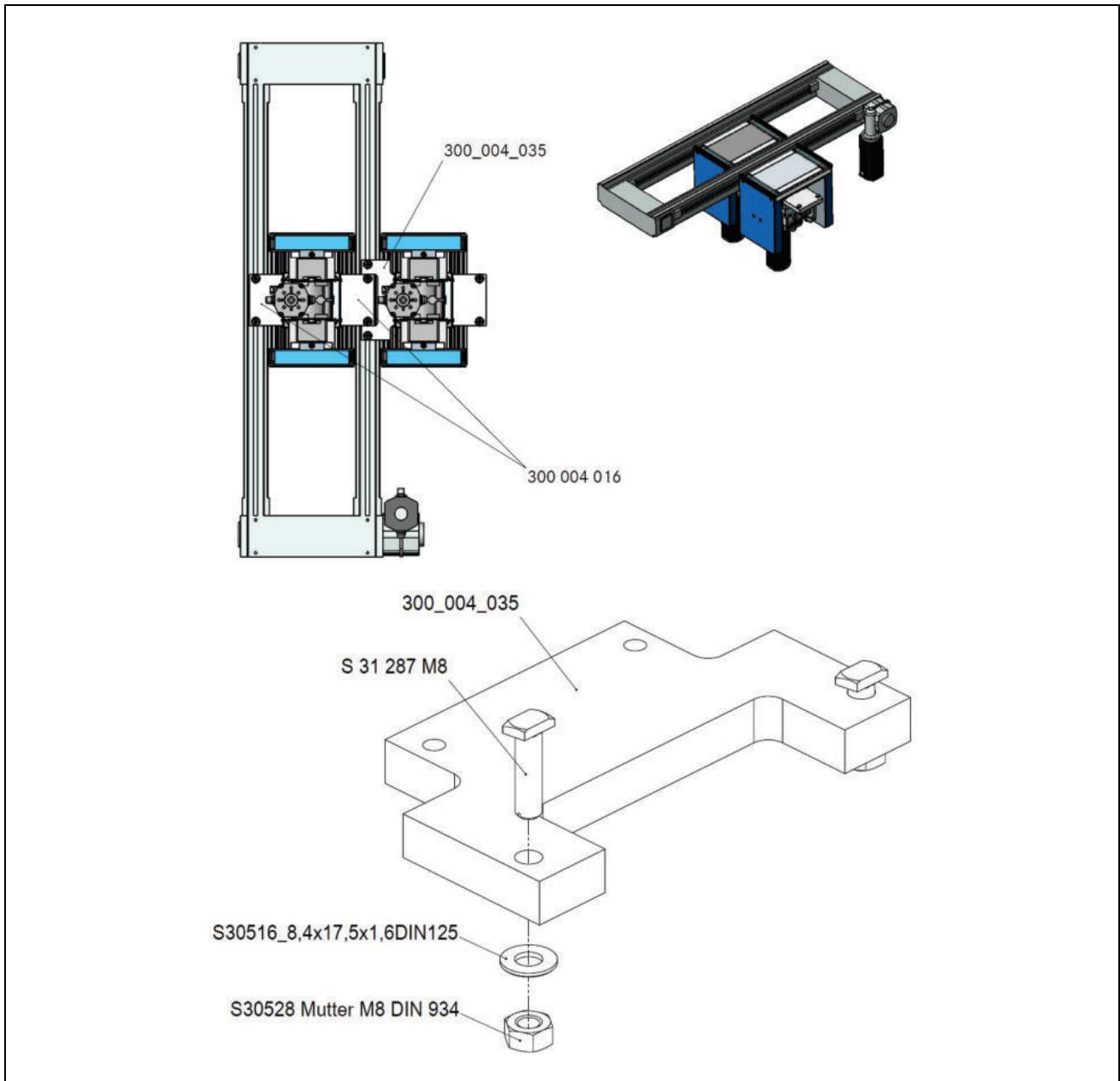

Fig. 11-6: Transfer unit 90° - 300 931 001

Quantity	Order number	Description
1	300 004 035	Retaining plate
2	300 004 016	Retaining plate
2	S31287	T-slotted screw
2	S30528	Screw nut M8 DIN934
2	S30516	Washer 8.4x17.5x1.6 DIN 125



A different mounting plate is required if two 90° transfer units are mounted on one profile.

11.6 300 921 001 Transfer unit 180° - PB160-200 / UB160 - 400

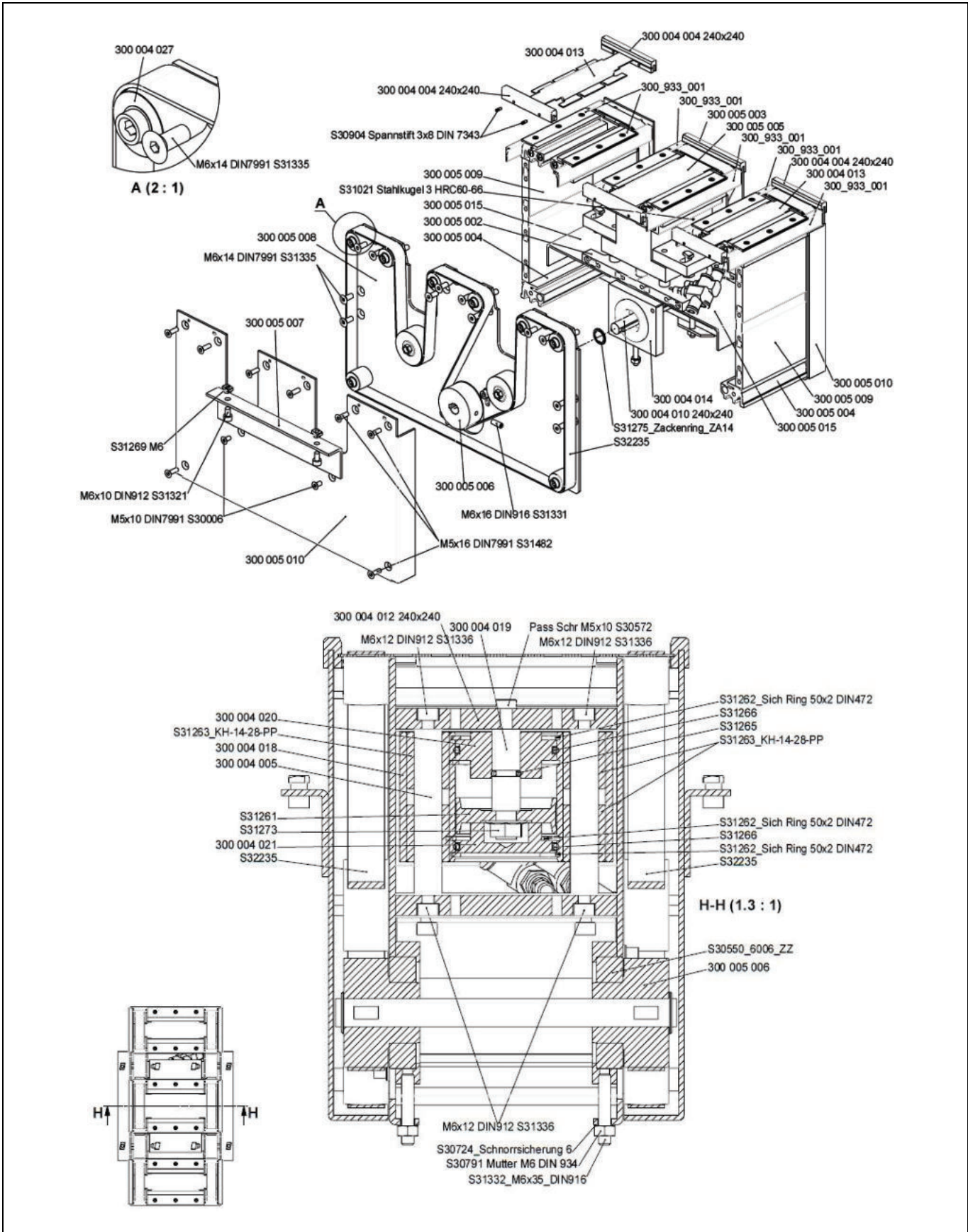

Fig. 11-7: Transfer unit 180° - 300 921 001 – PB160-200 / UB160-400 - sheet 1

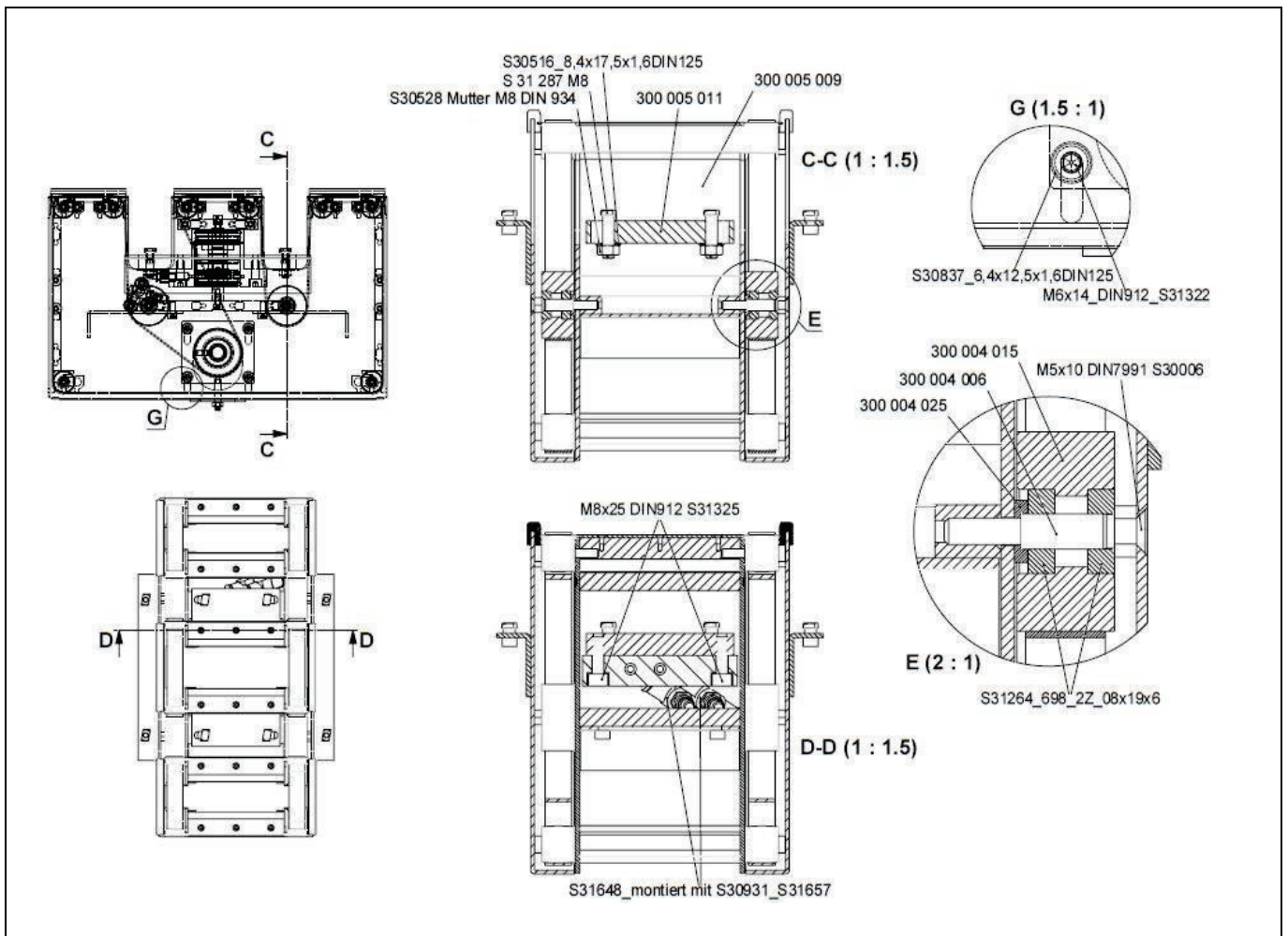

Fig. 11-8: Transfer unit 180° - 300 921 001 – PB160-200 / UB160-400 - sheet 2

Quantity	Order number	Description
1	300 005 002	Stiffener centre
2	300 005 003	Guide
2	300 005 004	Skirt
1	300 005 005	Cover plate
2	300 005 006	Drive wheel
2	300 005 007	Cover angle
2	300 005 008	Side panel
2	300 005 009	Stiffener exterior
2	300 005 010	Cover
2	300 005 011	Retaining plate
2	300 005 015	Edge protector
4	300 004 004	Guide
2	300 004 005	Guide shaft
4	300 004 006	Screw
1	300 004 010	Drive shaft
1	300 004 012	Stiffener
2	300 004 013	Cover plate
2	300 004 014	Bearing plate
4	300 004 015	Deflector roller
1	300 004 018	Cylinder casing
1	300 004 019	Piston rod
1	300 004 020	Piston guide

Quantity	Order number	Description
1	300 004 021	Cylinder cover
4	300 004 025	Washer B 6.4 DIN 125
16	300 004 027	Wheel roller
6	300 933 001	Conversion kit for standard U90 and U180
1	S31021	Ball d = 3mm
12	S30904	Dowel pin 3x8 DIN7343
1	S30572	Dowel screw M5x10
4	S30006	Screw M5x10 galv. DIN7991
24	S31335	M6x14 DIN7991
16	S31482	Countersunk screw M5x16 DIN7991
4	S31269	Sliding block M6
4	S31321	M6x10 DIN912 galv.
8	S31336	Screw M6x12 3M coated DIN912
4	S31322	ISK screw M6x14 3M coated DIN912
2	S31331	Screw M6x16 3M coated DIN916
2	S31332	Screw M6x35 3M coated DIN916
2	S30791	Screw nut M6 DIN934
2	S30724	Schnorr safety washer M6
4	S30837	Washer B 6.4 DIN 125
4	S31325	Screw M8x25 3M coated DIN912
4	S31287	T-slotted screw
4	S30516	Washer B 8.4 galvanised DIN 125 St
4	S30528	Hexagonal nut M8
4	S31263	Ball bushing KH 1428 P
2	S31275	Notched ring ZA 14
4	S31262	Retaining ring 50x2 DIN472
1	S31261	KPK 15x10x18N
1	S31265	O-ring 9x2.5
2	S31266	O-ring 44x3
1	S31273	Lock nut M10
2	S30550	Groove ball bearing 6006 2 Z
8	S31264	Groove ball bearing 698 2 Z
2	S31648	Throttle check valve GR-QS-6-LF
2	S30931	Hose PUN4 blue
2	S31657	Screw connection QS-1/8-6
2	S32235	Belt standard U180 PB<200

11.7 300 922 001 Transfer unit 180° - PB≤200-280 / UB160 - 400

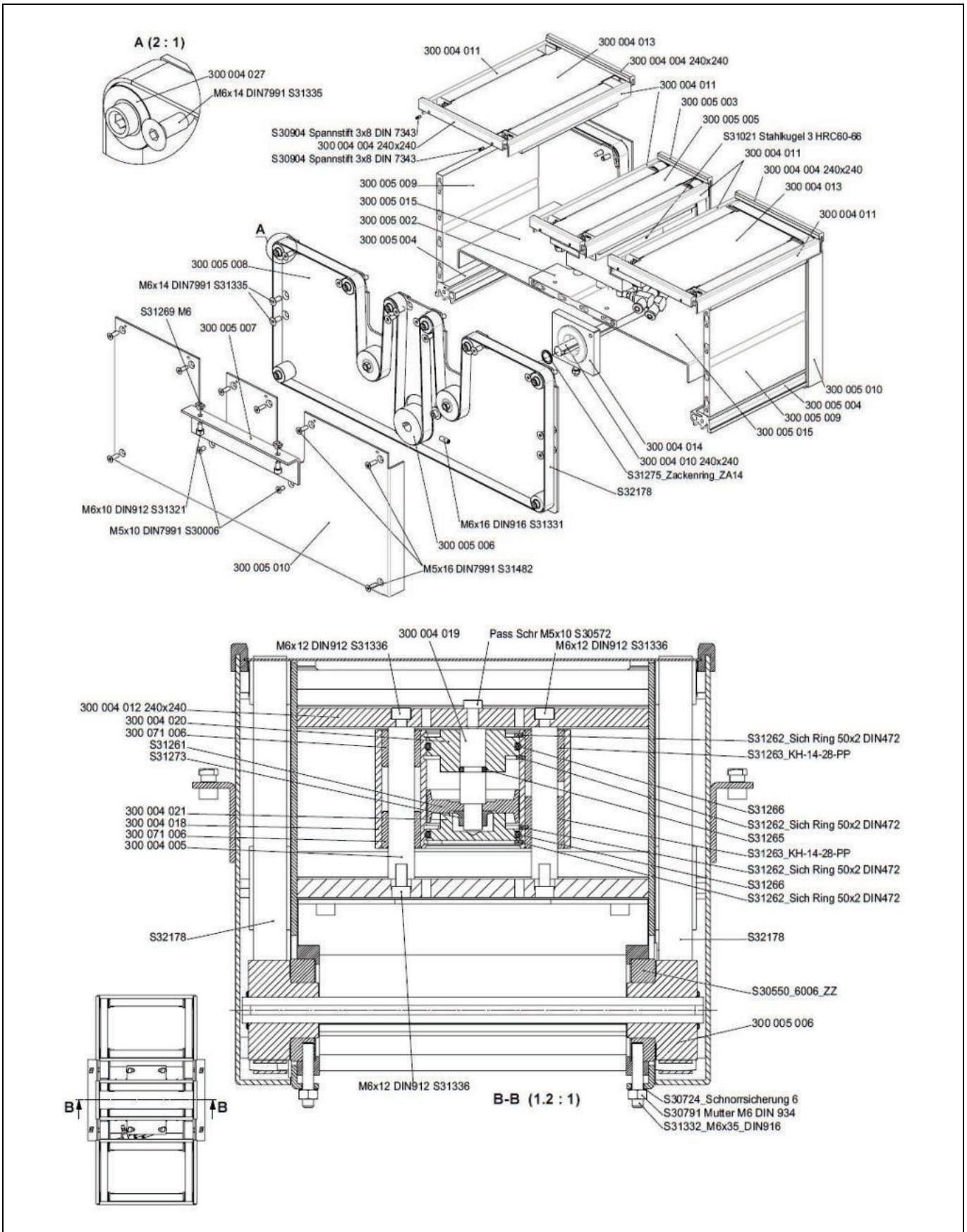

Fig. 11-9: Transfer unit 180° - 300 922 001 – PB≤200-280 / UB160-400 - sheet 1

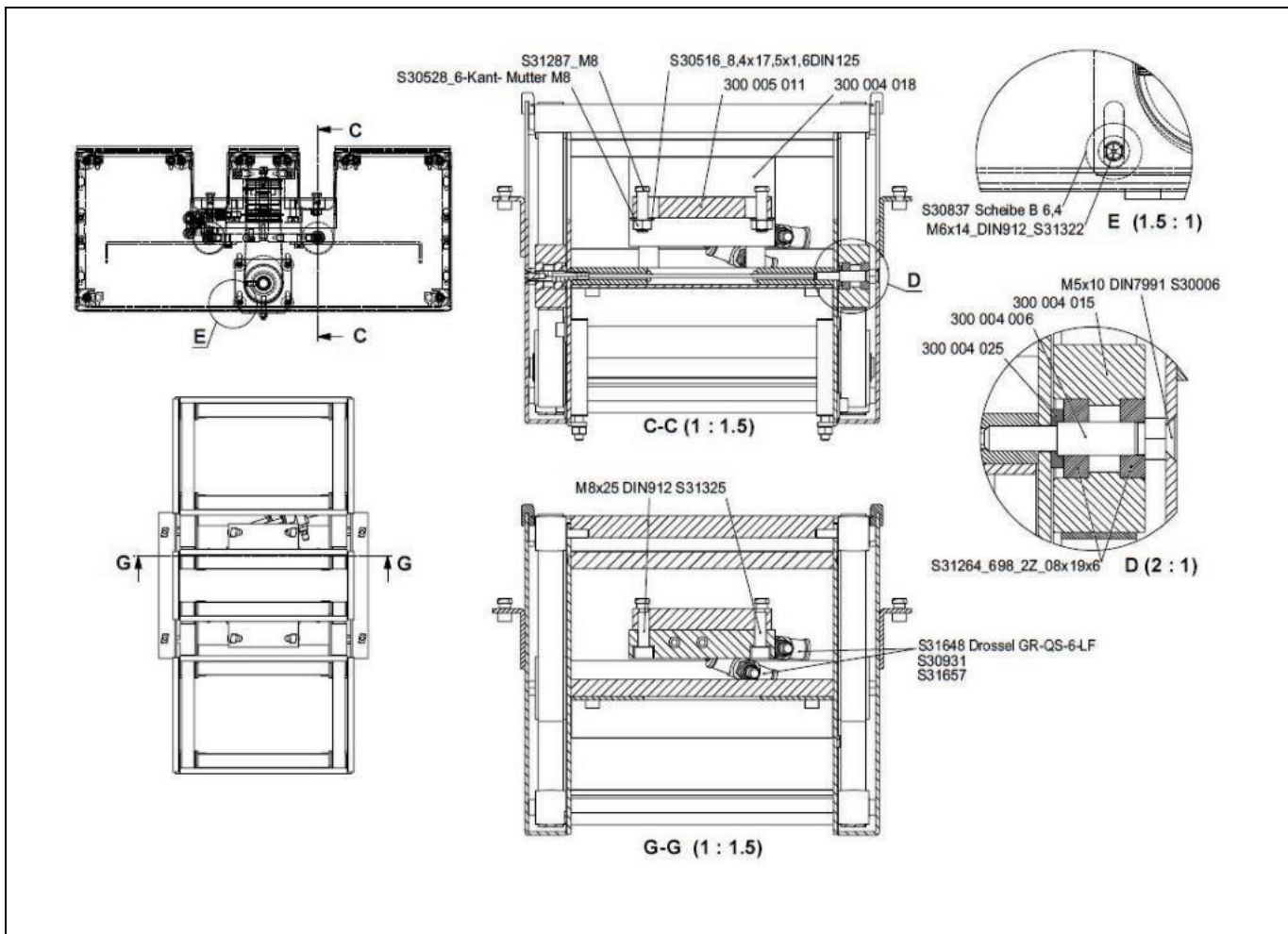

Fig. 11-10: Transfer unit 180° - 300 922 001 – PB≤200-280 / UB160-400 - sheet 2

Quantity	Order number	Description
4	300 004 004	Guide
2	300 004 005	Guide shaft
4	300 004 006	Screw
1	300 004 010	Drive shaft
6	300 004 011	Skirt
1	300 004 012	Stiffener
2	300 004 013	Cover plate
2	300 004 014	Bearing plate
4	300 004 015	Deflector roller
1	300 004 018	Cylinder casing
1	300 004 019	Piston rod
1	300 004 020	Piston guide
1	300 004 021	Cylinder cover
4	300 004 025	Washer B 6.4 DIN 125
16	300 004 027	Wheel roller
1	300 005 002	Stiffener centre
2	300 005 003	Guide
2	300 005 004	Skirt
1	300 005 005	Cover plate
2	300 005 006	Drive wheel
2	300 005 007	Cover angle

Quantity	Order number	Description
2	300 005 008	Side panel
2	300 005 009	Stiffener exterior
2	300 005 010	Cover
2	300 005 011	Retaining plate
2	300 005 015	Edge protector
2	300 071 006	Socket
4	S30006	Screw M5x10 galv. DIN7991
4	S30516	Washer B 8.4 galvanised DIN125 St
4	S30528	Screw nut M8 DIN934
2	S30550	Groove ball bearing 6006 2 Z
1	S30572	Dowel screw M5x10
2	S30724	Schnorr safety washer M6
2	S30791	Screw nut M6 DIN934
4	S30837	Washer B 6.4 DIN125
12	S30904	Dowel pin 3x8 DIN7343
2	S30931	Hose PUN4 blue
1	S31021	Ball d = 3mm
1	S31261	KPK 15x10x18N
4	S31262	Retaining ring 50x2 DIN472
1	S31263	Ball bushing KH 1428 P
8	S31264	Groove ball bearing 698 2 Z
1	S31265	O-ring 9x2.5
2	S31266	O-ring 44x3
4	S31269	Sliding block M6
1	S31273	Lock nut M10
2	S31275	Notched ring ZA 14
4	S31287	T-slotted screw
4	S31321	M6x10 DIN912 galv.
4	S31322	ISK screw M6x14 3M coated DIN912
4	S31325	Screw M8x25 3M coated DIN912
2	S31331	Screw M6x16 3M coated DIN916
2	S31332	Screw M6x35 3M coated DIN916
24	S31335	M6x14 DIN7991
8	S31336	Screw M6x12 3M coated DIN912
16	S31482	Countersunk screw M5x16 DIN7991
2	S32178	Belt: TT5/1-HC 18 wide
2	S31648	Throttle check valve GR-QS-6-LF
2	S31657	Screw connection QS-1/8-6

11.8 300 923 001 Transfer unit 180° - PB160-200 / UB >400

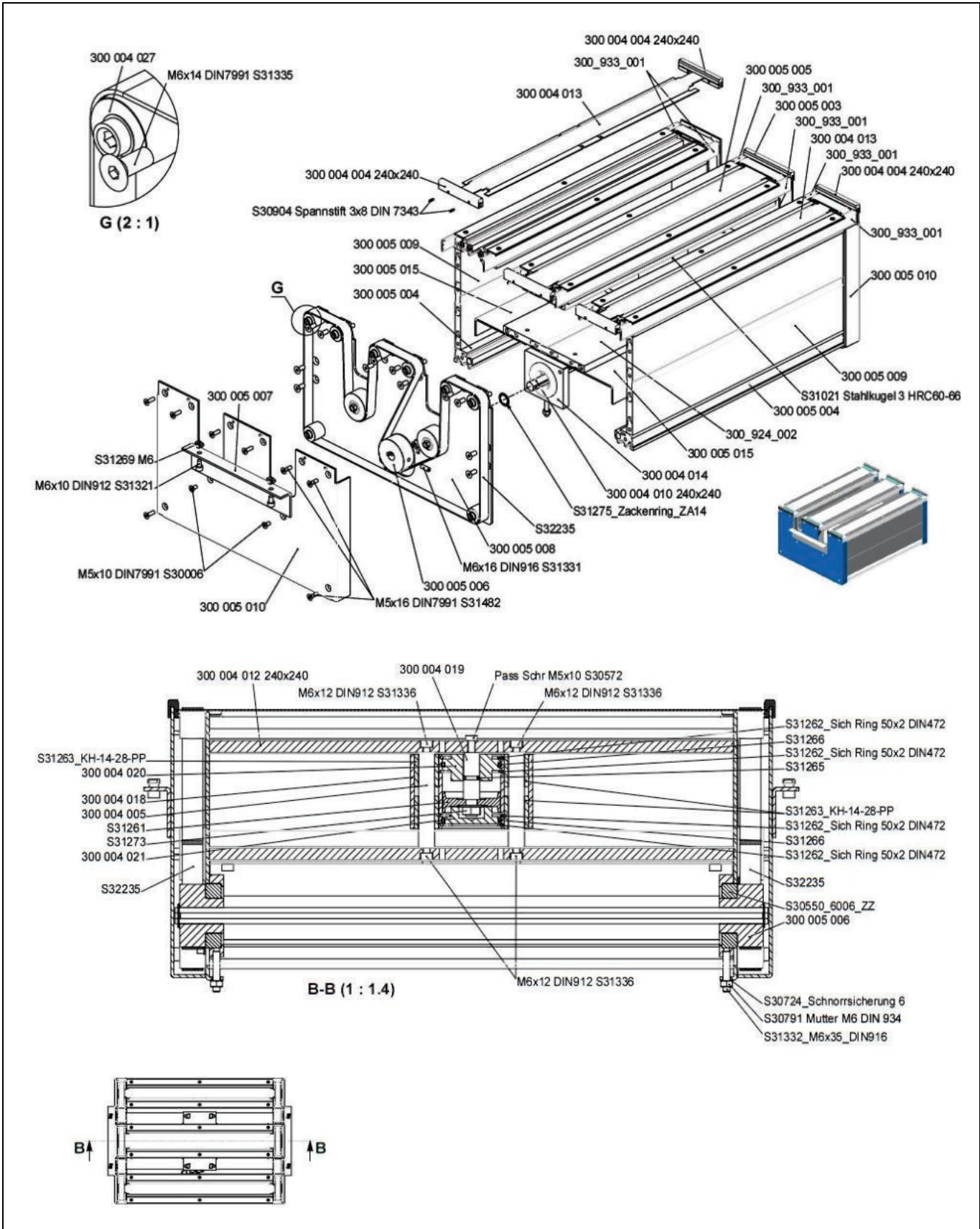

Fig. 11-11: Transfer unit 180° - 300 923 001 – PB160-200 / UB >400 - sheet 1

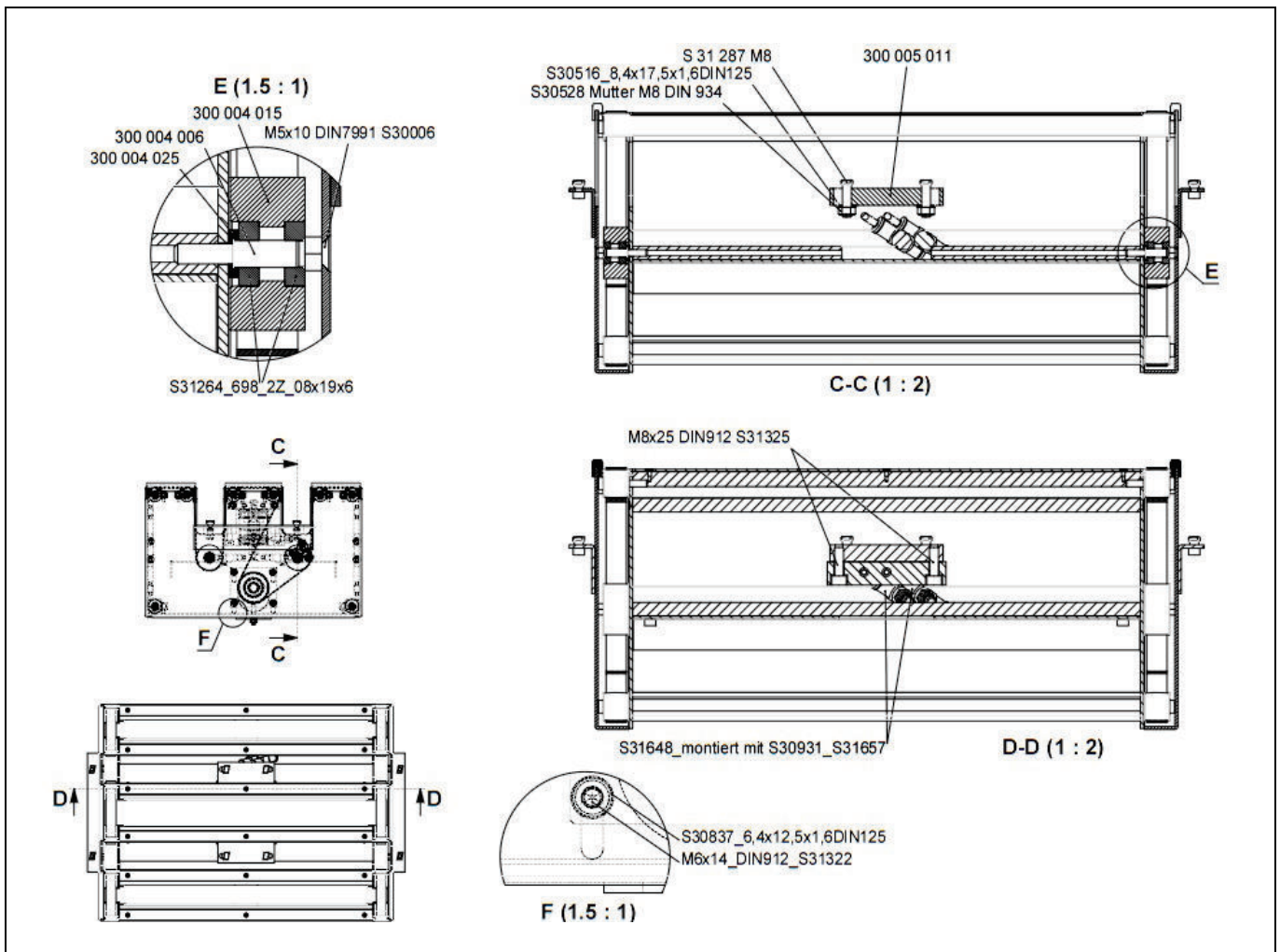

Fig11-12: Transfer unit 180° - 300 923 001 – PB160-200 / UB >400 - sheet 2

Quantity	Order number	Description
1	300 924 002	Stiffener centre
2	300 005 003	Guide
2	300 005 004	Skirt
1	300 005 005	Cover plate
2	300 005 006	Drive wheel
2	300 005 007	Cover angle
2	300 005 008	Side panel
2	300 005 009	Stiffener exterior
2	300 005 010	Cover
2	300 005 011	Retaining plate
2	300 005 015	Edge protector
4	300 004 004	Guide
2	300 004 005	Guide shaft
4	300 004 006	Screw
1	300 004 010	Drive shaft
1	300 004 012	Stiffener
2	300 004 013	Cover plate
2	300 004 014	Bearing plate
4	300 004 015	Deflector roller
1	300 004 018	Cylinder casing
1	300 004 019	Piston rod

Quantity	Order number	Description
1	300 004 020	Piston guide
1	300 004 021	Cylinder cover
4	300 004 025	Washer B 6.4 DIN 125
16	300 004 027	Wheel roller
6	300 933 001	Conversion kit for standard U90 and U180
1	S31021	Ball d = 3mm
12	S30904	Dowel pin 3x8 DIN7343
1	S30572	Dowel screw M5x10
4	S30006	Screw M5x10 galv. DIN7991
24	S31335	M6x14 DIN7991
16	S31482	Countersunk screw M5x16 DIN7991
4	S31269	Sliding block M6
4	S31321	M6x10 DIN912 galv.
8	S31336	Screw M6x12 3M coated DIN912
4	S31322	ISK screw M6x14 3M coated DIN912
2	S31331	Screw M6x16 3M coated DIN916
2	S31332	Screw M6x35 3M coated DIN916
2	S30791	Screw nut M6 DIN934
2	S30724	Schnorr safety washer M6
4	S30837	Washer B 6.4 DIN 125
4	S31325	Screw M8x25 3M coated DIN912
4	S31287	T-slotted screw
4	S30516	Washer B 8.4 galvanised DIN 125 St
4	S30528	Nut M8
4	S31263	Ball bushing KH 1428 P
2	S31275	Notched ring ZA 14
4	S31262	Retaining ring 50x2 DIN472
1	S31261	KPK 15x10x18N
1	S31265	O-ring 9x2.5
2	S31266	O-ring 44x3
1	S31273	Lock nut M10
2	S30550	Groove ball bearing 6006 2 Z
8	S31264	Groove ball bearing 698 2 Z
2	S31648	Throttle check valve GR-QS-6-LF
2	S30931	Hose PUN4 blue
2	S31657	Screw connection QS-1/8-6
2	S32235	Belt standard U 180 PB<200

11.9 300 924 001 Transfer unit 180° - PB200-280 / UB >400

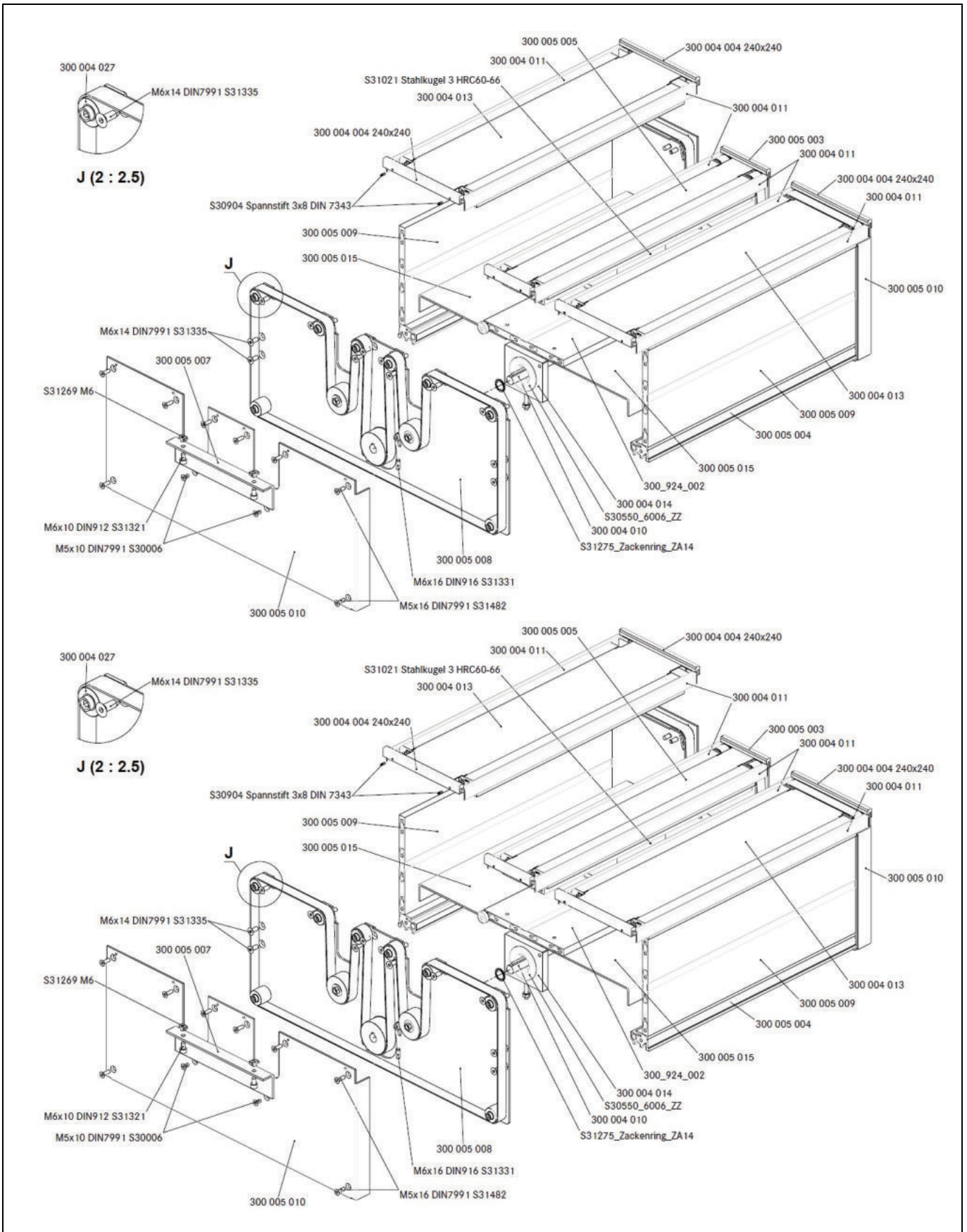

Fig11-13: Transfer unit 180° - 300 924 001 – PB200-280 / UB >400 - sheet 1

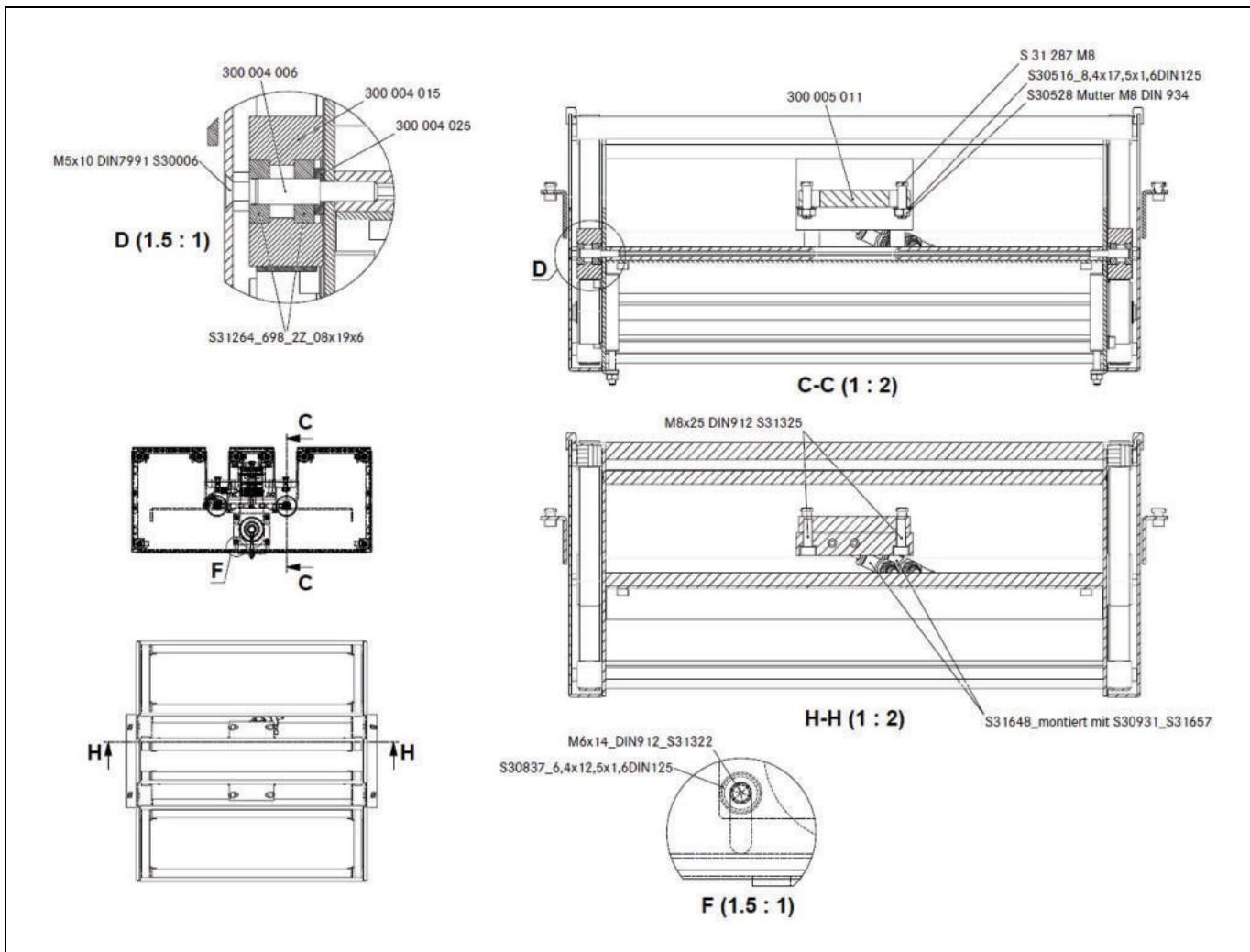

Fig. 11-14: Transfer unit 180° - 300 924 001 – PB200-280 / UB >400 - sheet 2

Quantity	Order number	Description
1	300 924 002	Stiffener centre
2	300 005 003	Guide
2	300 005 004	Skirt
1	300 005 005	Cover plate
2	300 005 006	Drive wheel
2	300 005 007	Cover angle
2	300 005 008	Side panel
2	300 005 009	Stiffener exterior
2	300 005 010	Cover
2	300 005 011	Retaining plate
2	300 005 015	Edge protector
4	300 004 004	Guide
2	300 004 005	Guide shaft
4	300 004 006	Screw
1	300 004 010	Drive shaft
6	300 004 011	Skirt
1	300 004 012	Stiffener
2	300 004 013	Cover plate
2	300 004 014	Bearing plate
4	300 004 015	Deflector roller
1	300 004 018	Cylinder casing

Quantity	Order number	Description
1	300 004 019	Piston rod
1	300 004 020	Piston guide
1	300 004 021	Cylinder cover
4	300 004 025	Washer B 6.4 DIN 125
16	300 004 027	Wheel roller
2	300 071 006	Socket
1	S31021	Ball d = 3mm
12	S30904	Dowel pin 3x8 DIN7343
1	S30572	Dowel screw M5x10
4	S30006	Screw M5x10 galv. DIN7991
24	S31335	M6x14 DIN 7991
16	S31482	Countersunk screw M5x16 DIN7991
4	S31269	Sliding block M6
4	S31321	M6x10 DIN912 galv.
8	S31336	Screw M6x12 3M coated DIN912
4	S31322	ISK screw M6x14 3M coated DIN912
2	S31331	Screw M6x16 3M coated DIN916
2	S31332	Screw M6x35 3M coated DIN916
2	S30791	Screw nut M6 DIN934
2	S30724	Schnorr safety washer M6
4	S30837	Washer B 6.4 DIN 125
4	S31325	Screw M8x25 3M coated DIN912
4	S31287	T-slotted screw
4	S30516	Washer B 8.4 galvanised DIN 125
4	S30528	Nut M8
2	S31263	Ball bushing KH 1428 P
2	S31275	Notched ring ZA 14
4	S31262	Retaining ring 50x2 DIN472
1	S31261	KPK 15x10x18N
1	S31265	O-ring 9x2.5
2	S31266	O-ring 44x3
1	S31273	Lock nut M10
2	S30550	Groove ball bearing 6006 2 Z
8	S31264	Groove ball bearing 698 2 Z
2	S31648	Throttle check valve GR-QS-6-LF
2	S30931	Hose PUN4 blue
2	S31657	Screw connection QS-1/8-6
2	S32178	Belt standard U180 PB200-280

11.10 300 925 001 Transfer unit 180° - PB280-400 / UB to 400

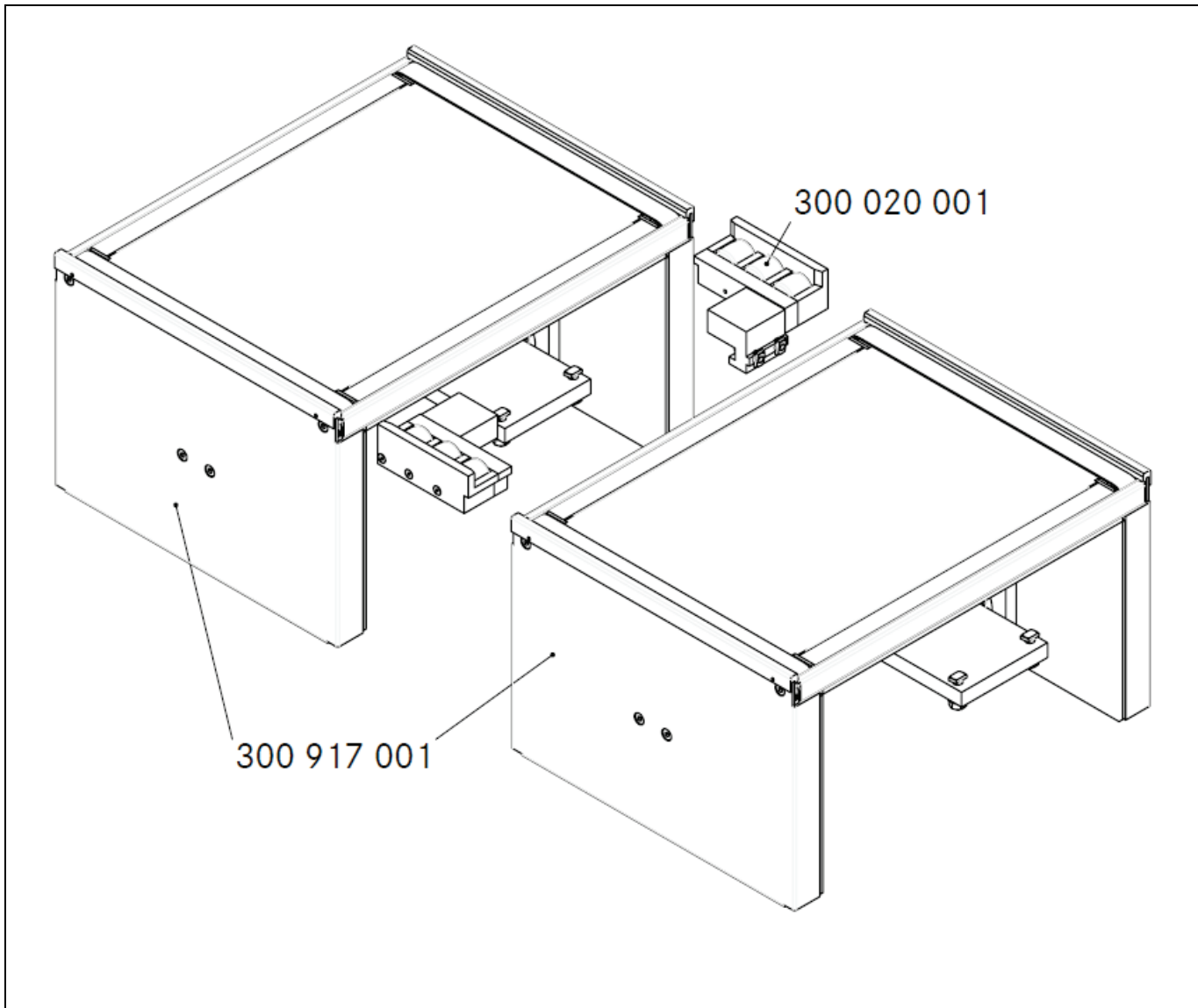

Fig. 11-15: Transfer unit 180° - 300 925 001 – PB280-400 / UB to 400

Quantity	Order number	Description
2	300 917 001	Transfer unit U90 PB200-400 UB to 400
1	300 020 001	WT guide

11.11 300 948 001 Transfer unit 180° - PB280-400 / UB >400

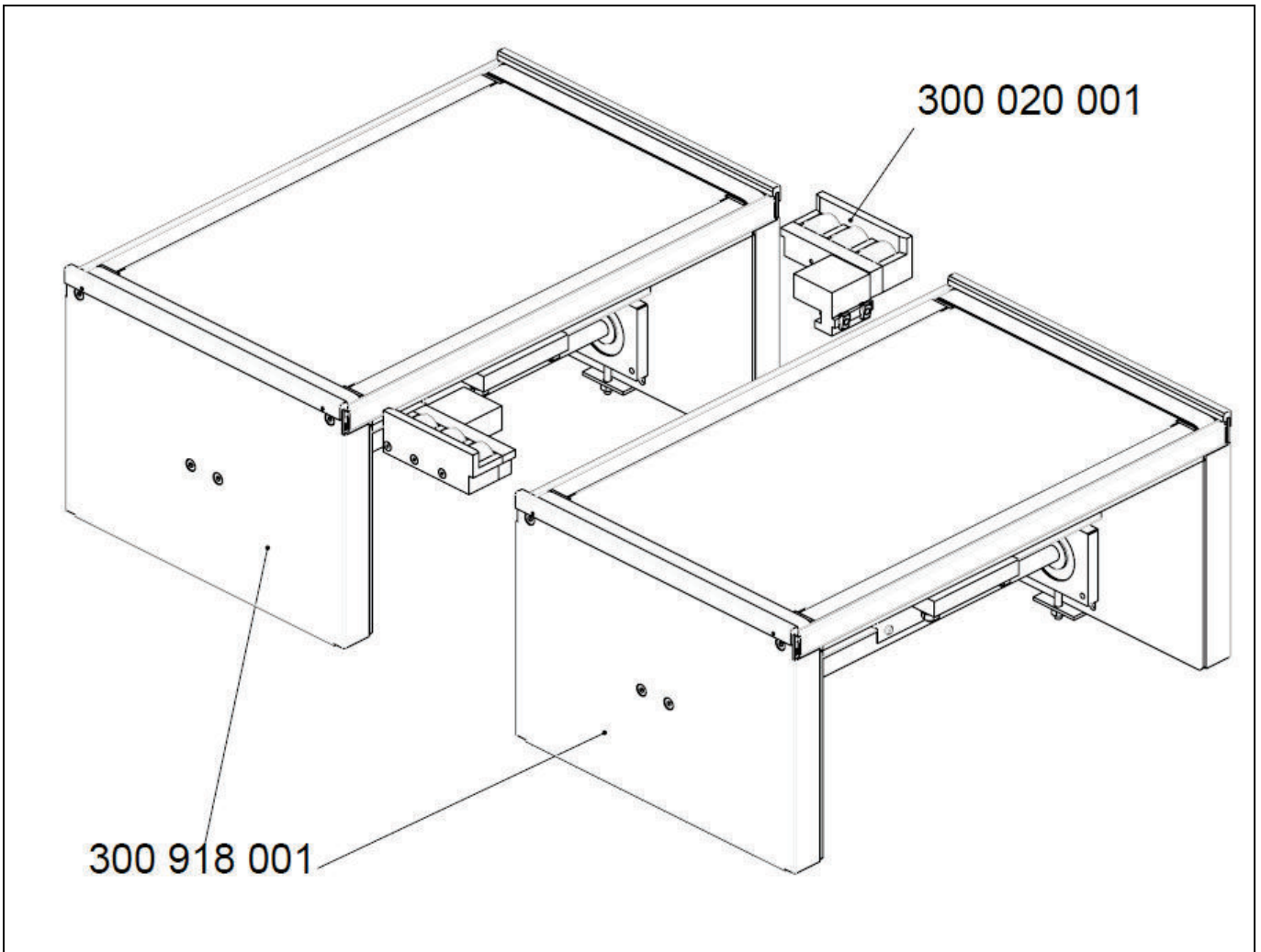

Fig. 11-16: Transfer unit 180° - 300 948 001 – PB280-400 / UB >400 - sheet 1

Quantity	Order number	Description
2	300 918 001	Transfer unit U90 PB200-400 UB>400
1	300 020 001	WT guide

11.12 300 919 001 Transfer unit 90° 1 ½-fold – for Wafer carrier

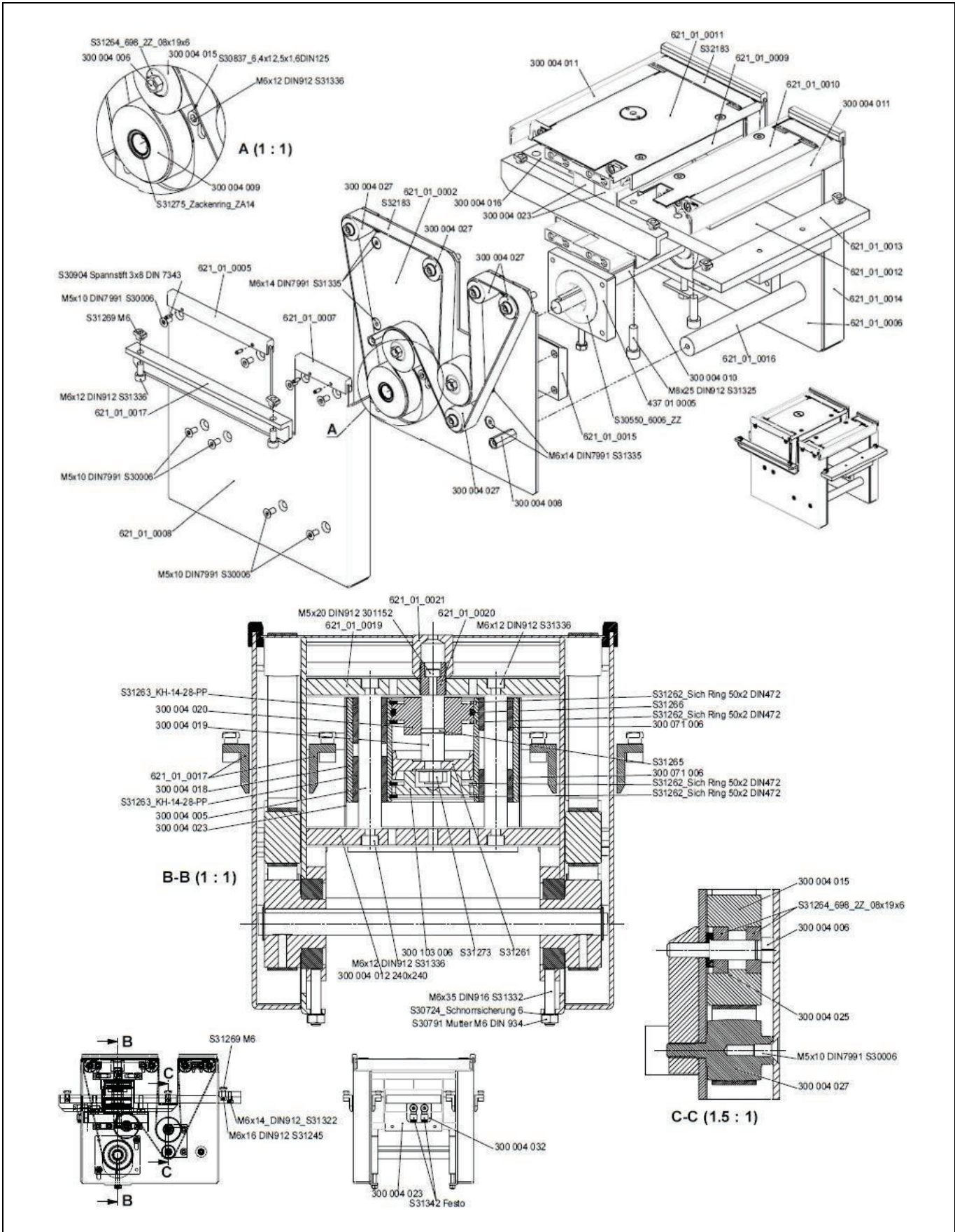

Fig. 11-17: Transfer unit 90° 1 ½-fold – for Wafer carrier - 300 919 001

Quantity	Order number	Description
2	300 004 005	Guide shaft
4	300 004 006	Screw
4	300 004 008	Spacer bolt
2	300 004 009	Drive wheel
1	300 004 010	Drive shaft
2	300 004 011	Skirt
1	300 004 012	Stiffener
4	300 004 015	Deflector roller
1	300 004 016	Retaining plate
1	300 004 018	Cylinder casing
1	300 004 019	Piston rod
1	300 004 020	Piston guide
2	300 004 023	Cover
4	300 004 025	Washer
10	300 004 027	Wheel roller
1	300 004 032	Cover
2	300 071 006	Socket
1	300 103 006	Cylinder cover
2	437 01 0005	Bearing plate
1	621 01 0002	Side panel
2	621 01 0005	Guide
1	621 01 0006	Side panel
2	621 01 0007	Outer guide
1	621 01 0008	Cover
2	621 01 0009	Skirt
1	621 01 0010	Cover plate
1	621 01 0011	Cover plate, centre
1	621 01 0012	Retaining plate
1	621 01 0013	Joining plate
1	621 01 0014	Cover
2	621 01 0015	Bearing block
1	621 01 0016	Stiffening shaft
4	621 01 0017	Stiffener
1	621 01 0019	Stiffening plate
1	621 01 0020	Bolt
1	621 01 0021	Adjusting bush
8	S30904	Dowel pin 3x8 DIN7343
20	S30006	M5x10 DIN7991 galv.
1	301152	Adjusting screw M5x20 DIN912
16	S31336	M6x12 3M coated DIN912
20	S31335	M6x14 3M coated DIN7991
2	S31322	M6x14 DIN912
2	S31765	M6x16 DIN912
2	S31332	M6x35 3M coated DIN916
2	S30791	Nut M6 DIN EN 24035 (DIN439)
10	S31269	Slotted nut M6
4	S30837	Washer B6.4 DIN125 galv.
2	S30724	Schnorr protection ring 6
4	S31325	M8x25 DIN912
1	S31273	Lock nut M10
1	S31265	O-ring 9x2.5
2	S31275	Notched ring ZA14
1	S31261	KPK 15x10x18N
2	S31266	O-ring 44x3
4	S31262	Retaining ring 50x2 DIN472
2	S31263	Ball bushing
8	S31264	698 ZZ 08x19x6 DIN625-T1
2	S30550	Groove ball bearing 6006 ZZ DIN625-T1
2	S31342	Throttle check valve GRLA 1/8 QS6 Festo
2	S32183	Belt for U90

11.13 300 920 001 Transfer unit 90° 1 1/2-fold

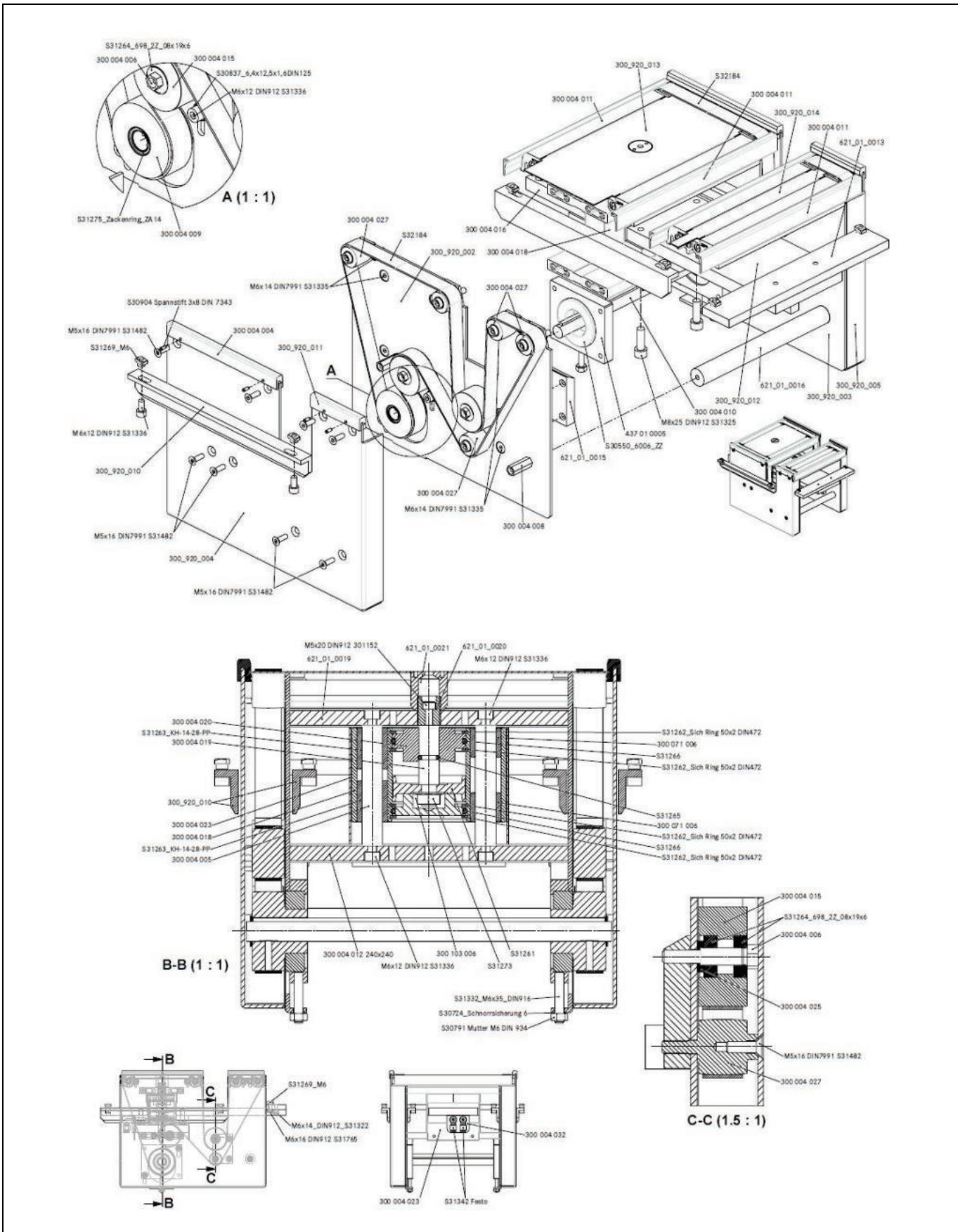

Fig. 11-18: Transfer unit 90° 1 1/2-fold - 300 920 001

Quantity	Order number	Description
2	300 004 004	Guide
2	300 004 005	Guide shaft
4	300 004 006	Screw
4	300 004 008	Spacer bolt
2	300 004 009	Drive wheel
1	300 004 010	Drive shaft
4	300 004 011	Skirt
1	300 004 012	Stiffener
4	300 004 015	Deflector roller
1	300 004 016	Retaining plate
1	300 004 018	Cylinder casing
1	300 004 019	Piston rod
1	300 004 020	Piston guide
2	300 004 023	Cover
4	300 004 025	Washer
10	300 004 027	Wheel roller
1	300 004 032	Cover
2	300 071 006	Socket
1	300 103 006	Cylinder cover
2	437 01 0005	Bearing plate
1	300 920 002	Side panel
1	300 920 003	Side panel
1	300 920 004	Cover
1	300 920 005	Cover
4	300 920 010	Stiffener
2	300 920 011	Outer guide
1	300 920 012	Retaining plate
1	300 920 013	Cover plate, centre
1	300 920 014	Cover plate
1	621 01 0013	Joining plate
2	621 01 0015	Bearing block
1	621 01 0016	Stiffening shaft
1	621 01 0019	Stiffening plate
1	621 01 0020	Bolt
1	621 01 0021	Adjusting bush
8	S30904	Dowel pin 3x8 DIN7343
16	S31482	M5x16 DIN7991
1	301152	Adjusting screw M5x20 DIN912
16	S31336	M6x12 3M coated DIN912
20	S31335	M6x14 3M coated DIN7991
2	S31322	M6x14 DIN912
2	S31765	M6x16 DIN912
2	S31332	M6x35 3M coated DIN916
2	S30791	Nut M6 DIN EN 24035 (DIN439)
10	S31269	Slotted nut M6
4	S30837	Washer B6.4 DIN125 galv.
2	S30724	Schnorr safety washer 6
4	S31325	M8x25 DIN912
1	S31273	Lock nut M10
1	S31265	O-ring 9x2.5
2	S31275	Notched ring ZA14
1	S31261	KPK 15x10x18N
2	S31266	O-ring 44x3
4	S31262	Retaining ring 50x2 DIN472
2	S31263	Ball bushing
8	S31264	698 2Z 08x19x6 DIN625-T1
2	S30550	Groove ball bearing 6006 ZZ DIN625-T1
2	S31342	Throttle check valve GRLA 1/8 QS6 Festo
2	S32184	Belt for U90

11.14 930 191 001 Transfer unit 90° - with 4G read head right

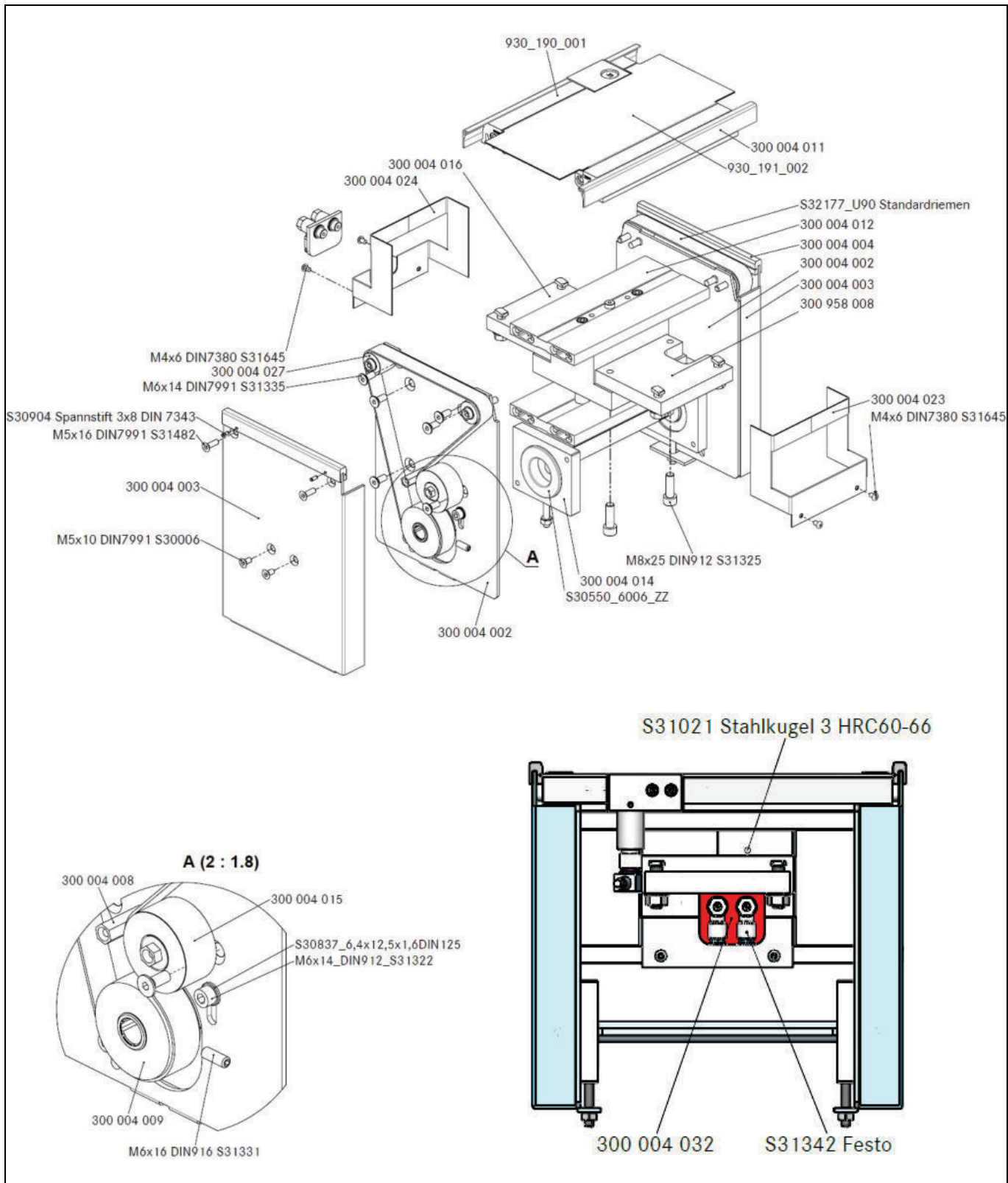

Fig. 11-19: Transfer unit 90° with 4G read head right - 930 191 001

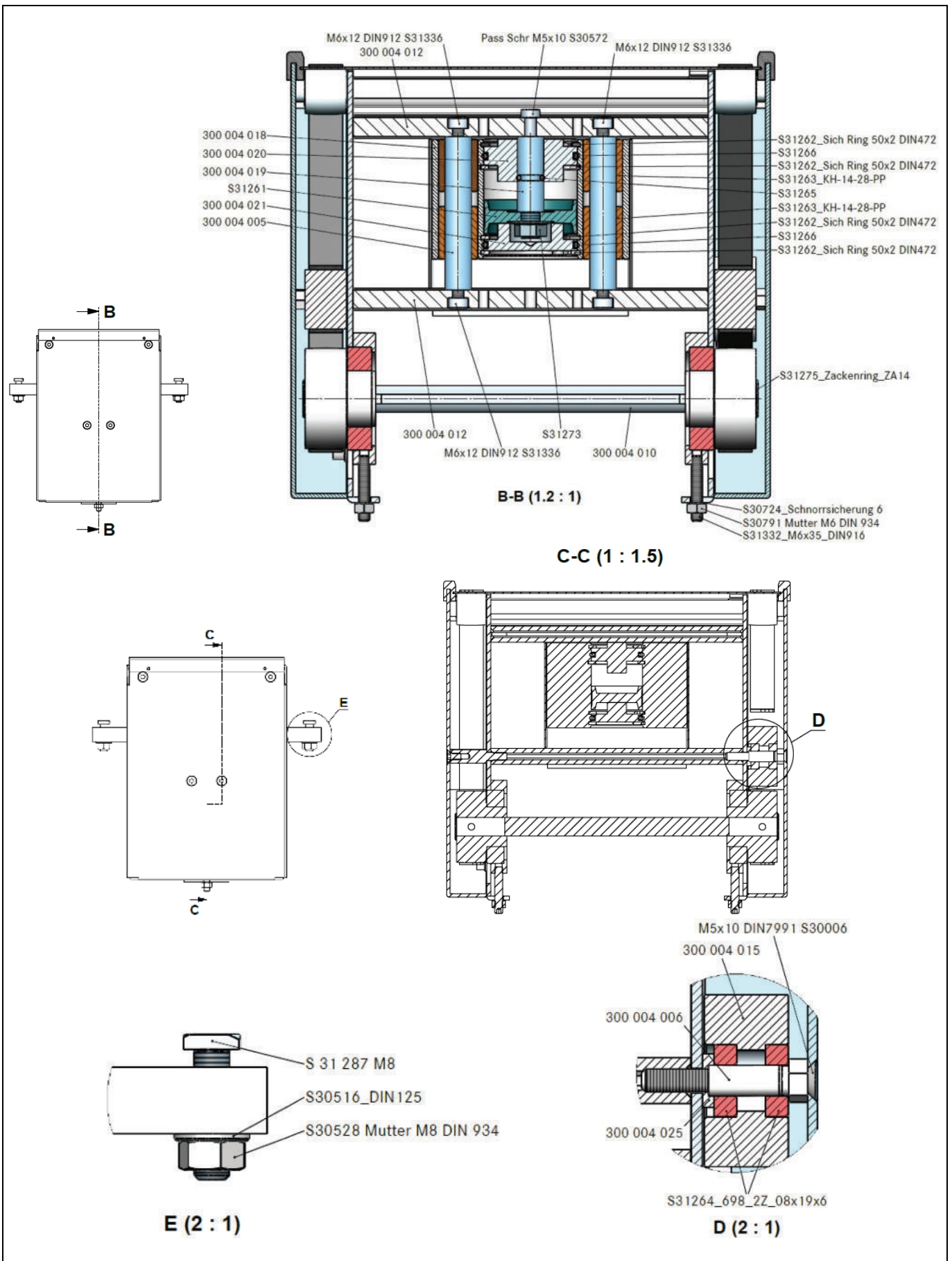

Fig. 11-20: Transfer unit 90° with 4G read head right - 930 191 001

Quantity	Order number	Description
1	930 191 002	Cover plate
2	300 004 002	Side panel 90°
2	300 004 003	Cover 90°
2	300 004 004	Guide
2	300 004 005	Guide shaft
2	300 004 006	Screw
2	300 004 008	Spacer bolt
2	300 004 009	Drive wheel
1	300 004 010	Drive shaft
1	300 004 011	Skirt
2	300 004 012	Stiffener
2	300 004 014	Bearing plate
2	300 004 015	Deflector roller
1	300 004 016	Retaining plate
1	300 004 018	Cylinder casing
1	300 004 019	Piston rod
1	300 004 020	Piston guide
1	300 004 021	Cylinder cover
1	300 004 023	Cover
1	300 004 024	Cover
2	300 004 025	Washer
4	300 004 027	Wheel roller
1	300 004 032	Cover
1	300 958 008	Retaining plate
1	930 190 001	Skirt
1	S31021	Ball d = 3mm
4	S30904	Dowel pin 3x8 DIN7343
4	S31645	M4x6 3M coated DIN7380
4	S30006	M5x10 DIN7991
1	S30572	Dowel screw M5x10
4	S31482	M5x16 DIN7991
4	S31336	M6x12 3M coated DIN 912
12	S31335	M6x14 DIN7991
4	S31322	M6x14 3M coated DIN 912
2	S31331	M6x16 3M coated DIN 916
2	S31332	M6x35 3M coated DIN 916
2	S30791	Nut M6 DIN934
2	S30724	Schnorr safety washer M6
4	S30837	Washer B 6,4 DIN125
4	S31325	M8x25 3M coated DIN912
2	S30550	Groove ball bearing 6006 2 Z
1	S31261	KPK 15x10x18N
4	S31262	Retaining ring 50x2 DIN472
4	S31263	Ball bushing KH 1428 P
4	S31264	Groove ball bearing 698 2 Z
1	S31265	O-Ring 9x2,5
2	S31266	O-Ring 44x3
1	S31273	Lock nut M10
2	S31342	Throttle check valve GRLA1/8QS6
2	S31275	Notched ring ZA 14
2	S32177	Belt: TT5/1-HC 18
4	S31287	T-slotted screw
4	S30528	Nut M8 DIN934
4	S30516	Washer B 8,4 galvanised DIN125

11.15 930 187 001 Transfer unit 90° - with 4G read head left

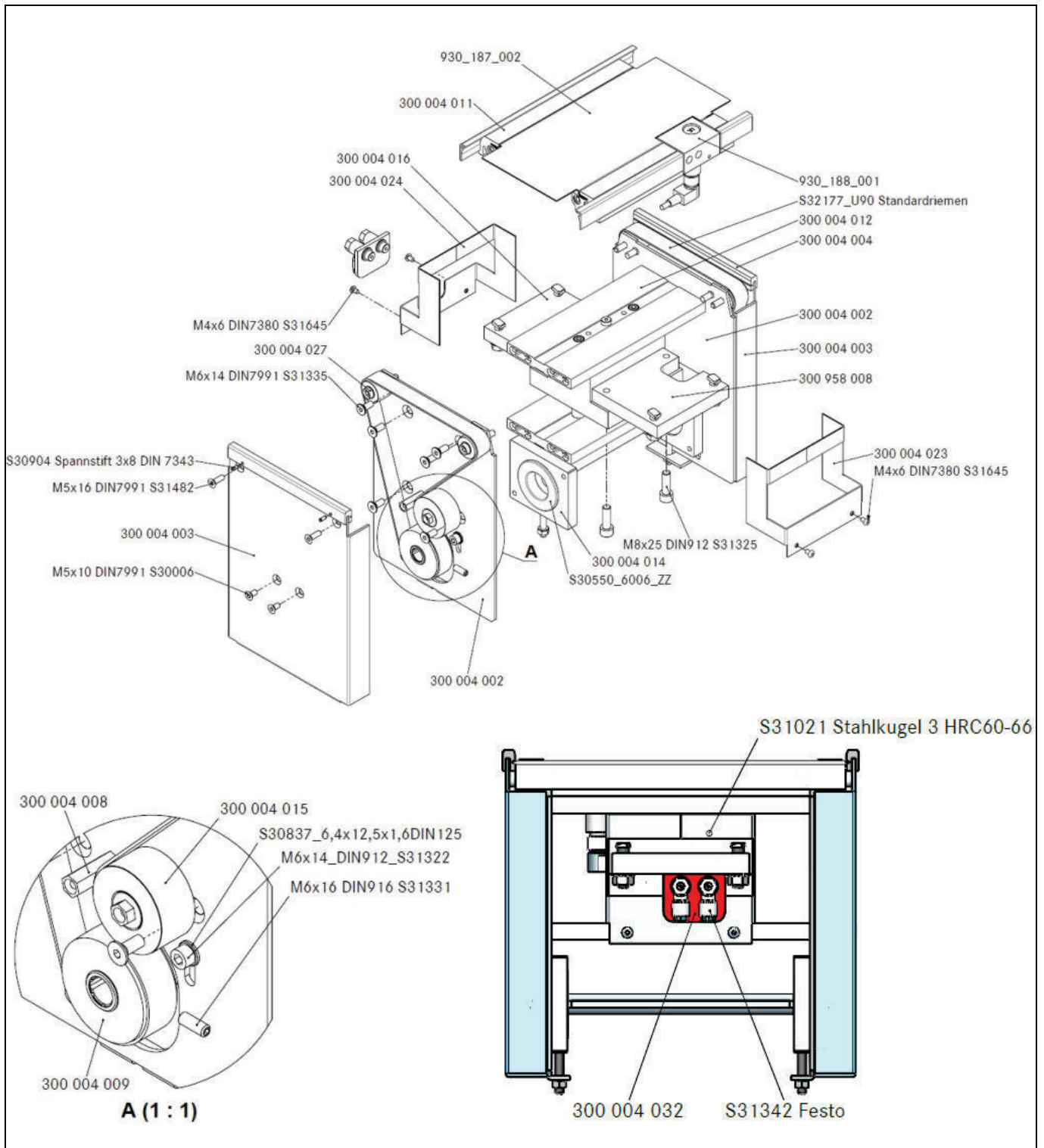

Fig. 11-21: Transfer unit 90° with 4G read head left - 930 187 001

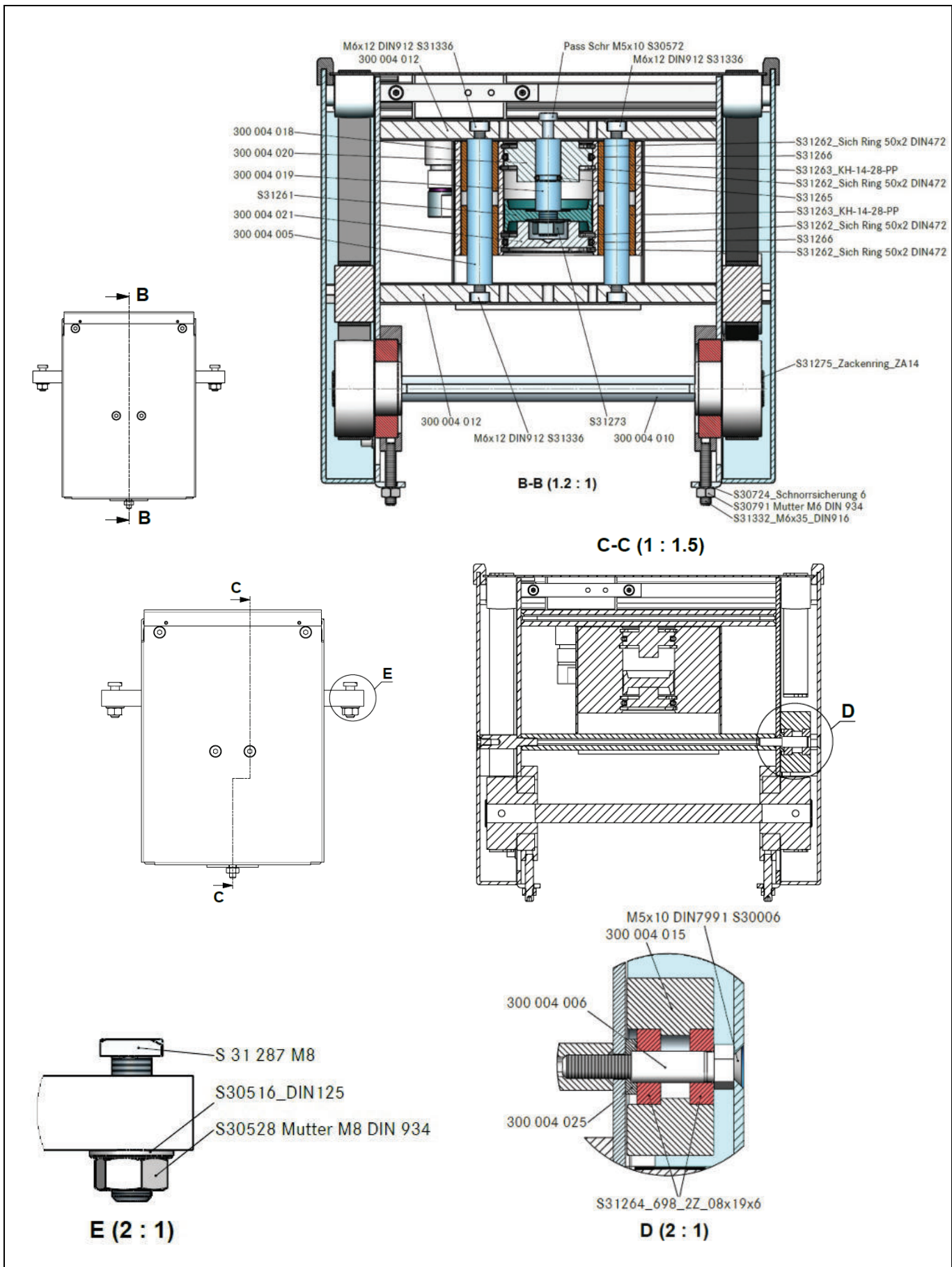

Fig. 11-22: Transfer unit 90° with 4G read head left - 930 187 001

Quantity	Order number	Description
1	930 187 002	Cover plate
2	300 004 002	Side panel
2	300 004 003	Cover
2	300 004 004	Guide
2	300 004 005	Guide shaft
2	300 004 006	Screw
2	300 004 008	Spacer bolt
2	300 004 009	Drive wheel
1	300 004 010	Drive shaft
1	300 004 011	Skirt
2	300 004 012	Stiffener
2	300 004 014	Bearing plate
2	300 004 015	Deflector roller
1	300 004 016	Retaining plate
1	300 004 018	Cylinder casing
1	300 004 019	Piston rod
1	300 004 020	Piston guide
1	300 004 021	Cylinder cover
1	300 004 023	Cover
1	300 004 024	Cover
2	300 004 025	Washer
4	300 004 027	Wheel roller
1	300 004 032	Cover
1	300 958 008	Retaining plate
1	930 188 001	Skirt
1	S31021	Ball d = 3mm
4	S30904	Dowel pin 3x8 DIN7343
4	S31645	M4x6 DIN7380
4	S30006	M5x10 DIN7991
1	S30572	Dowel screw M5x10
4	S31482	M5x16 DIN7991
4	S31336	M6x12 DIN912
12	S31335	M6x14 DIN7991
4	S31322	M6x14 DIN912
2	S31331	M6x16 DIN916
2	S31332	M6x35 DIN916
4	S31325	M8x25 DIN912
2	S30791	Screw nut M6 DIN934
4	S30528	Screw nut M8 DIN934
4	S31287	T-slotted screw M8
2	S30724	Schnorr safety washer M6
4	S30837	Washer B 6,4 DIN125
4	S30516	Washer B 8,4 DIN125
2	S30550	Groove ball bearing 6006 2 Z
1	S31261	KPK 15x10x18N
4	S31262	Retaining ring 50x2 DIN472
2	S31275	Notched ring ZA 14
2	S31263	Ball bushing KH 1428 P
4	S31264	Groove ball bearing 698 2 Z
1	S31265	O-Ring 9x2,5
2	S31266	O-Ring 44x3
1	S31273	Lock nut M10
2	S31342	Throttle check valve GRLA1/8QS6
2	S32177	Belt for all standard U90

11.16 930 146 001 Transfer unit 90° - with 4G read head right, HGL valve

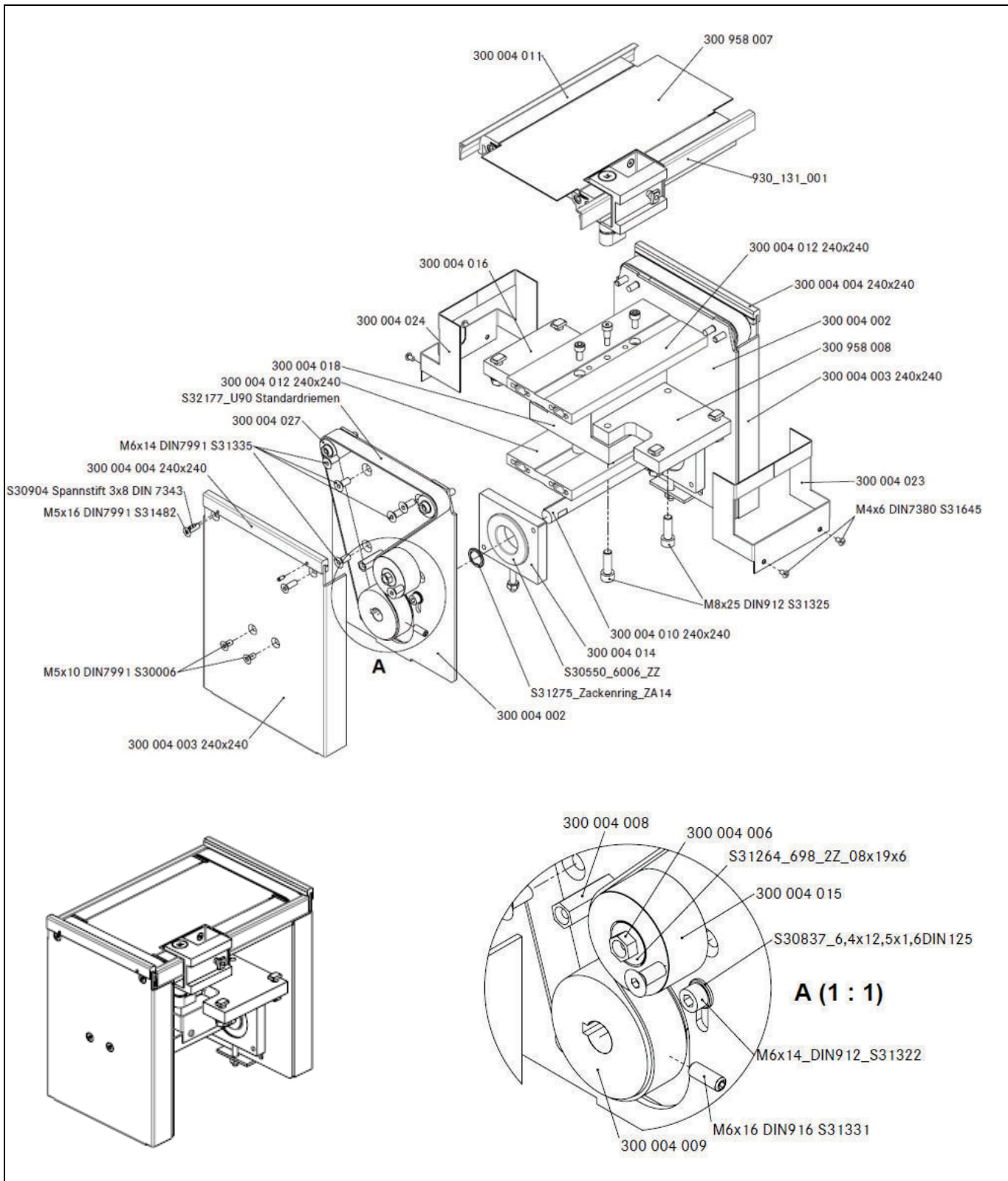

Fig. 11-23: Transfer unit 90° with 4G read head right, with HGL valve - 930 146 001

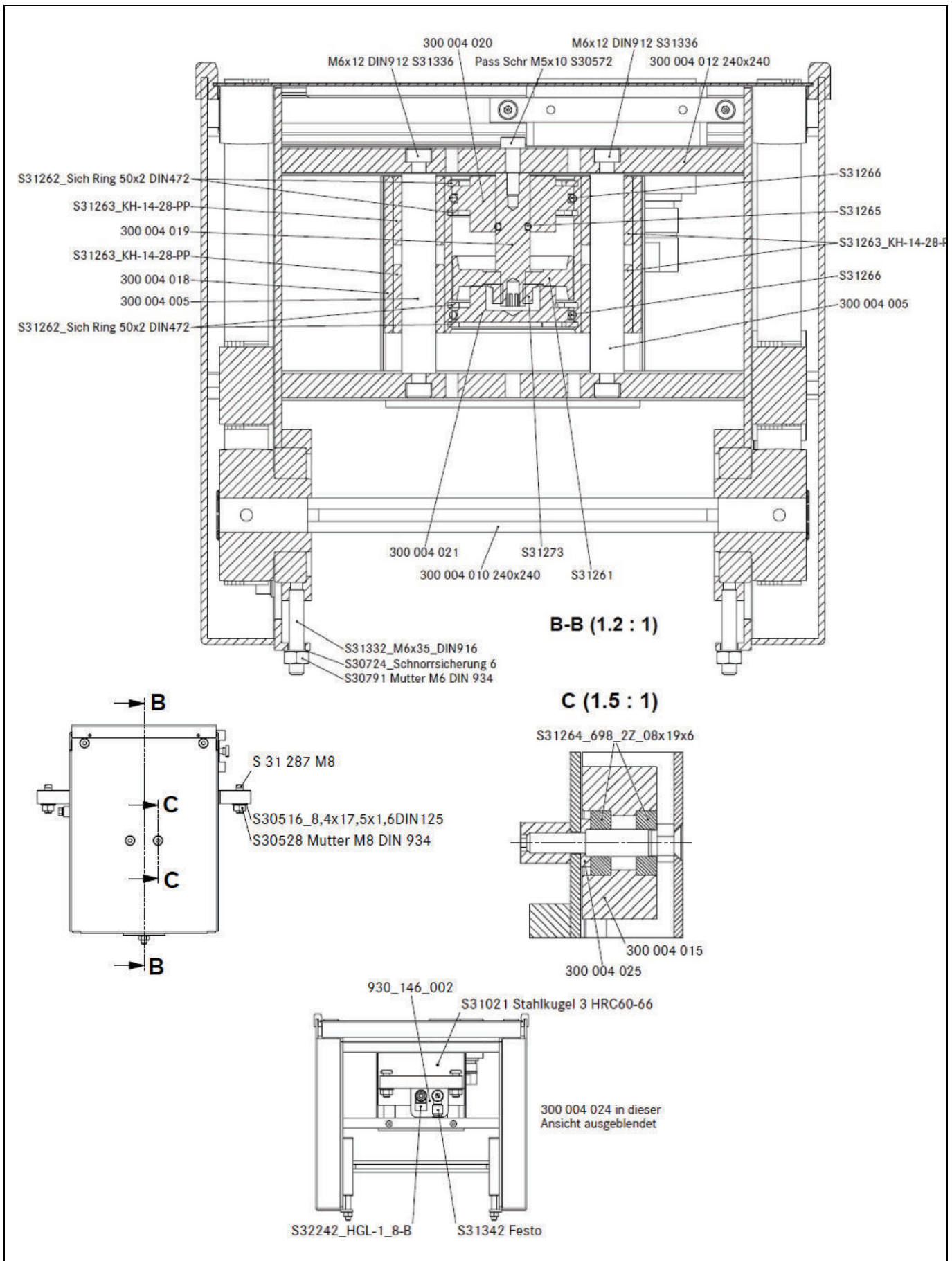

Fig. 11-24: Transfer unit 90° with 4G read head right, with HGL valve - 930 146 001

Quantity	Order number	Description
1	930 146 002	Cover plate
2	300 004 002	Side panel
2	300 004 003	Cover
2	300 004 004	Guide
2	300 004 005	Guide shaft
2	300 004 006	Screw
2	300 004 008	Spacer bolt
2	300 004 009	Drive wheel
1	300 004 010	Drive shaft
1	300 004 011	Skirt
2	300 004 012	Stiffener
2	300 004 014	Bearing plate
2	300 004 015	Deflector roller
1	300 004 016	Retaining plate
1	300 004 018	Cylinder casing
1	300 004 019	Piston rod
1	300 004 020	Piston guide
1	300 004 021	Cylinder cover
1	300 004 023	Cover
1	300 004 024	Cover
2	300 004 025	Washer
4	300 004 027	Wheel roller
1	300 958 007	Cover
1	300 958 008	Retaining plate
1	930 131 001	Skirt
1	S31021	Ball d = 3mm
4	S30904	Dowel pin 3x8 DIN7343
4	S31645	M4x6 DIN7380
4	S30006	M5x10 DIN7991
1	S30572	Dowel screw M5x10
4	S31482	M5x16 DIN7991
4	S31336	M6x12 DIN912
12	S31335	M6x14 DIN7991
4	S31322	M6x14 DIN912
2	S31331	M6x16 DIN916
2	S31332	M6x35 DIN916
2	S30791	Screw nut M6 DIN934
2	S30724	Schnorr safety washer M6
4	S30837	Washer B 6,4 DIN125
4	S31325	Screw M8x25 DIN912
2	S30550	Groove ball bearing 6006 2 Z
1	S31261	KPK 15x10x18N
4	S31262	Retaining ring 50x2 DIN472
2	S31263	Ball bushing KH 1428 P
4	S31264	Groove ball bearing 698 2 Z
1	S31265	O-Ring 9x2,5
2	S31266	O-Ring 44x3
1	S31273	Lock nut M10
1	S31342	Throttle check valve GRLA1/8QS6
1	S32242	Throttle check valve HGL-1/8-B
2	S31275	Notched ring ZA 14
2	S32177	Belt for all standard U90
4	S31287	T-slotted screw M8
4	S30528	Screw nut M8 DIN934
4	S30516	Washer B 8,4 DIN125

12 Accessories

12.1 Drive motors - drive sets

12.1.1 AC WEG motor with terminal board / hanging – 300 932 001

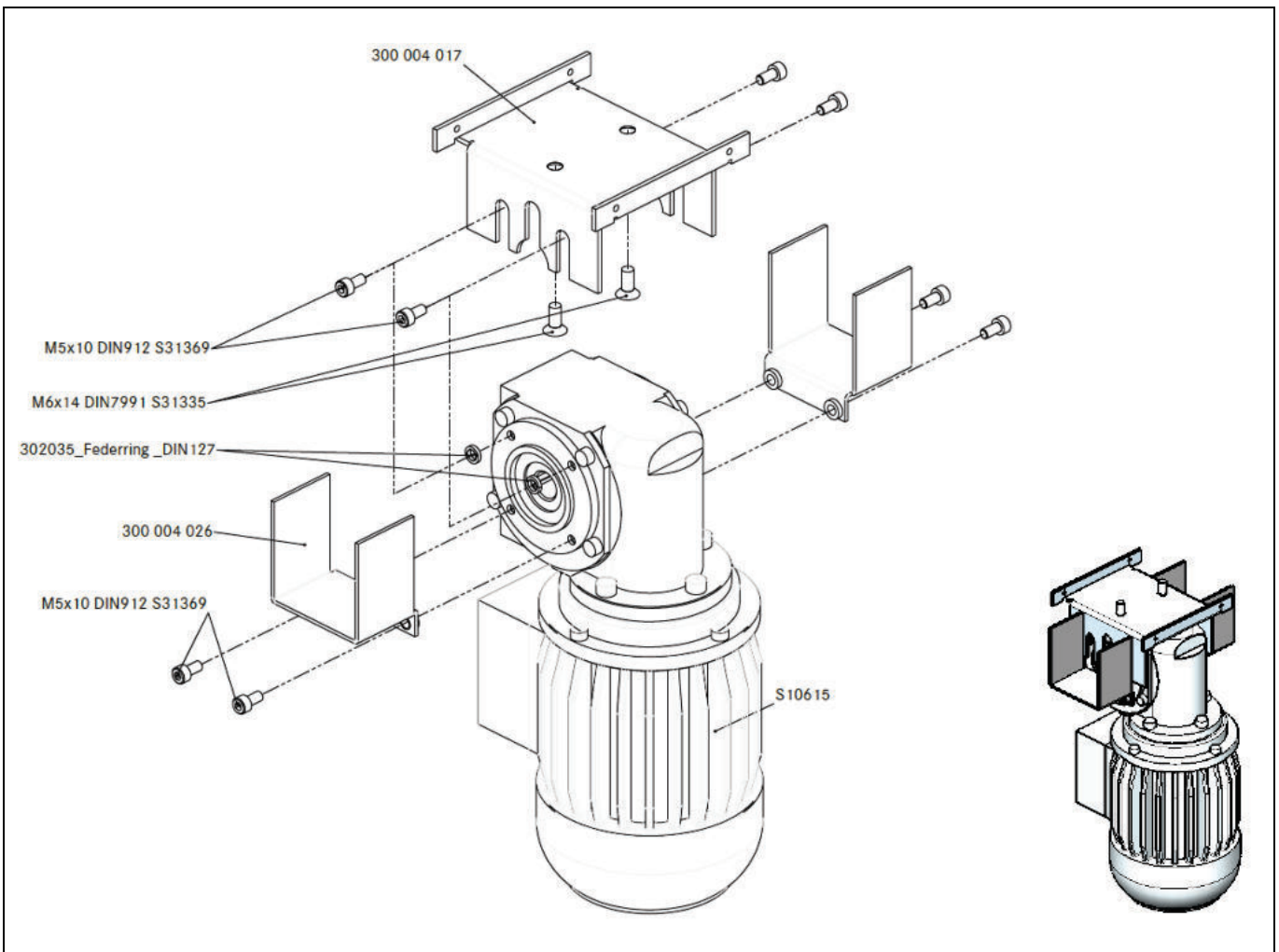







Fig. 12-1: AC WEG motor with terminal board – 300 932 001

	Order number	Description	Quantity
	300 004 017	Torque reaction support	1
	300 004 026	Cover	2
	S10615	WEG AC motor	1
	S31369	M5x10 DIN912	8
	S31335	M6x14 DIN7991	2
	302035	Spring lock washer DIN127	4

12.1.2 AC WEG motor with terminal board / fixed – 300 968 001

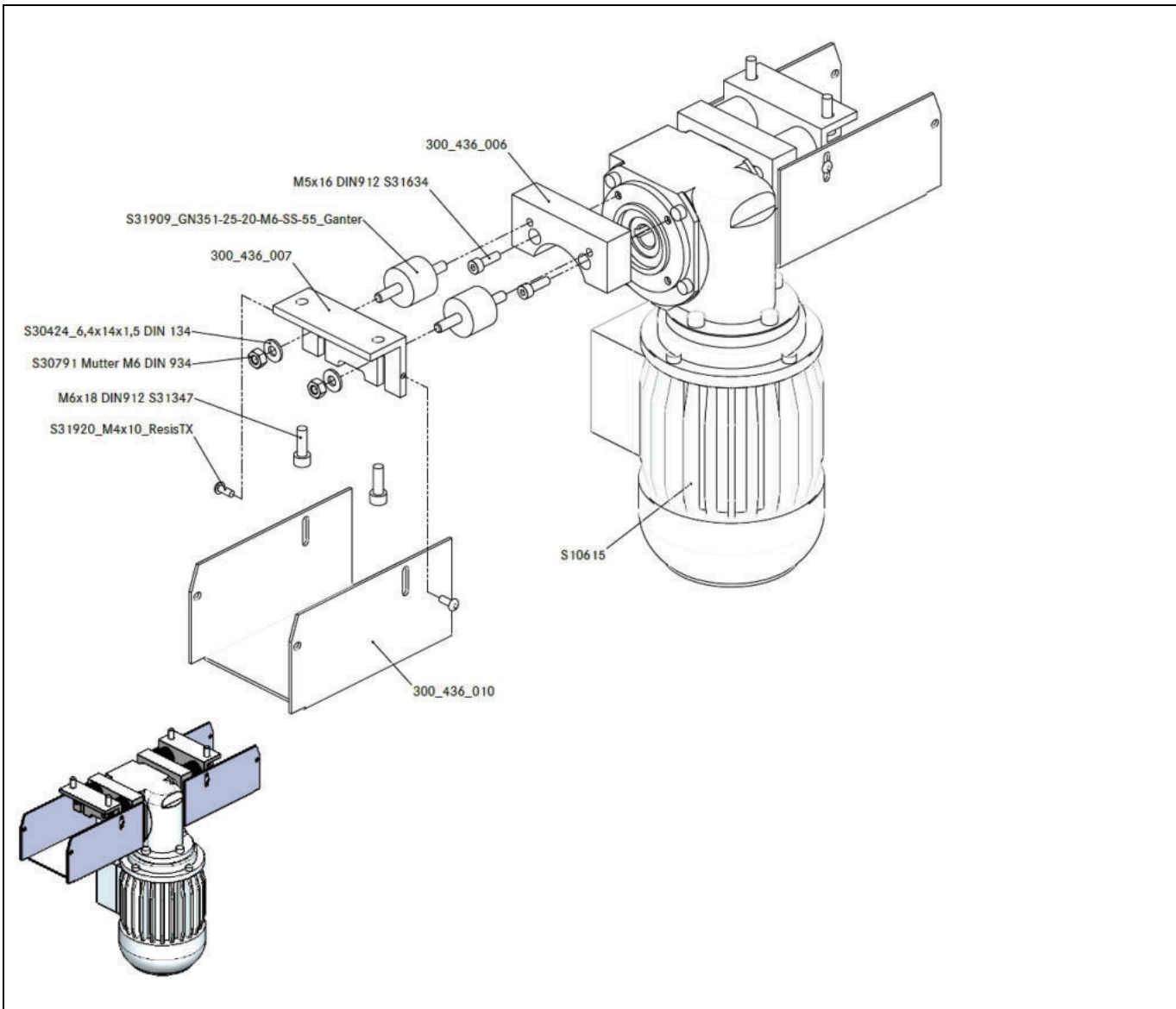











Fig. 12-2: AC WEG motor with terminal board / fixed – 300 968 001

	Order number	Description	Quantity
	300 436 006	Retaining block	2
	300 436 007	Bracket	2
	300 436 010	Cover	2
	S10615	AC WEG motor with terminal box	1
	S31920	M4x10 Resis TX	4
	S31634	M5x16 DIN912	4
	S31909	GN351-25-20-M6-SS-55	4
	S31347	M6x18 DIN912	4
	S30424	Washer 6.4x14x1.5 DIN134	4
	S30791	Screw nut M6 DIN934	4

12.1.3 AC WEG motor / hanging – 300 963 001

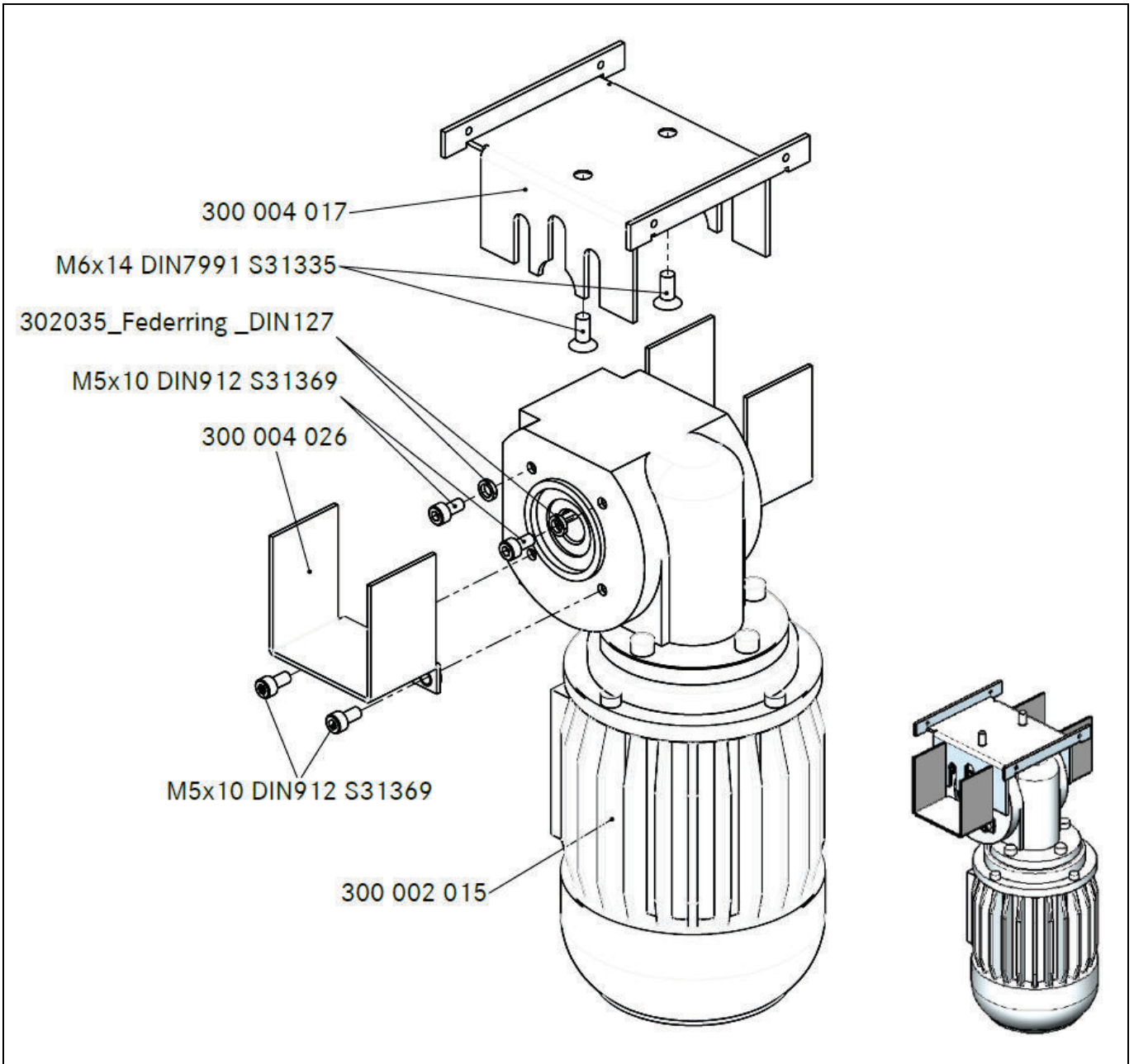







Fig. 12-3: AC WEG motor / hanging – 300 963 001

	Order number	Description	Quantity
	300 002 015	Gear motor	1
	300 004 017	Torque reaction support	1
	300 004 026	Cover	2
	S31369	M5x10 DIN912	8
	S31335	M6x14 DIN7991	2
	302035	Spring lock washer DIN127	4

12.1.4 AC WEG motor / fixed – 300 967 001

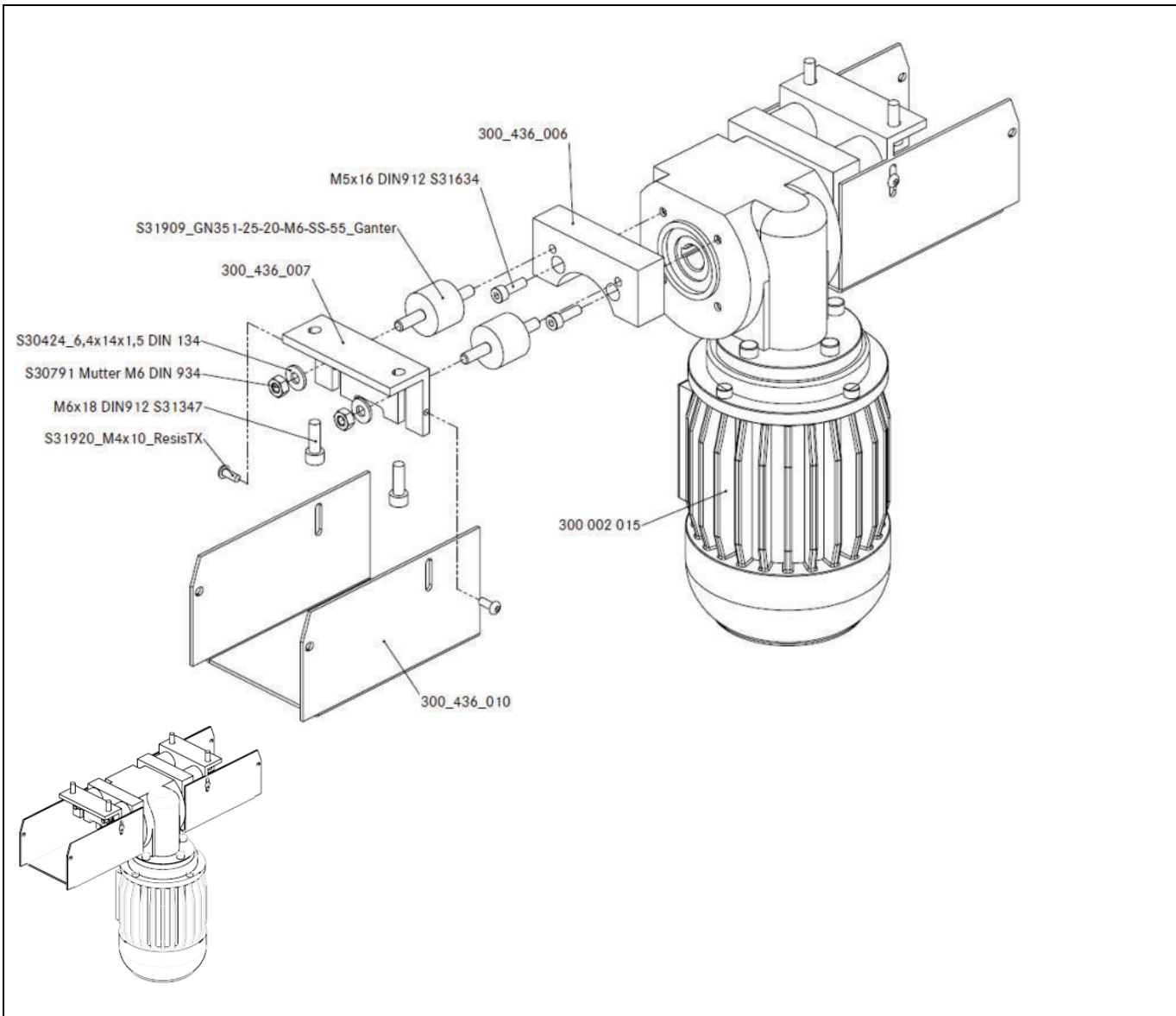











Fig12-4: AC WEG motor / fixed – 300 967 001

	Order number	Description	Quantity
	300 002 015	WEG AC motor	1
	300 436 006	Retaining block	2
	300 436 007	Bracket	2
	300 436 010	Cover	2
	S31920	M4x10 Resis TX	4
	S31634	M5x 16 DIN912	4
	S31909	GN35 1-25-20-M6-SS-55	4
	S31347	M6x18 DIN912	4
	S30424	Washer 6.4x14x1.5 DIN134	4
	S30791	Screw nut M6 DIN934	4

12.1.5 EC WEG motor / hanging – 300 965 001

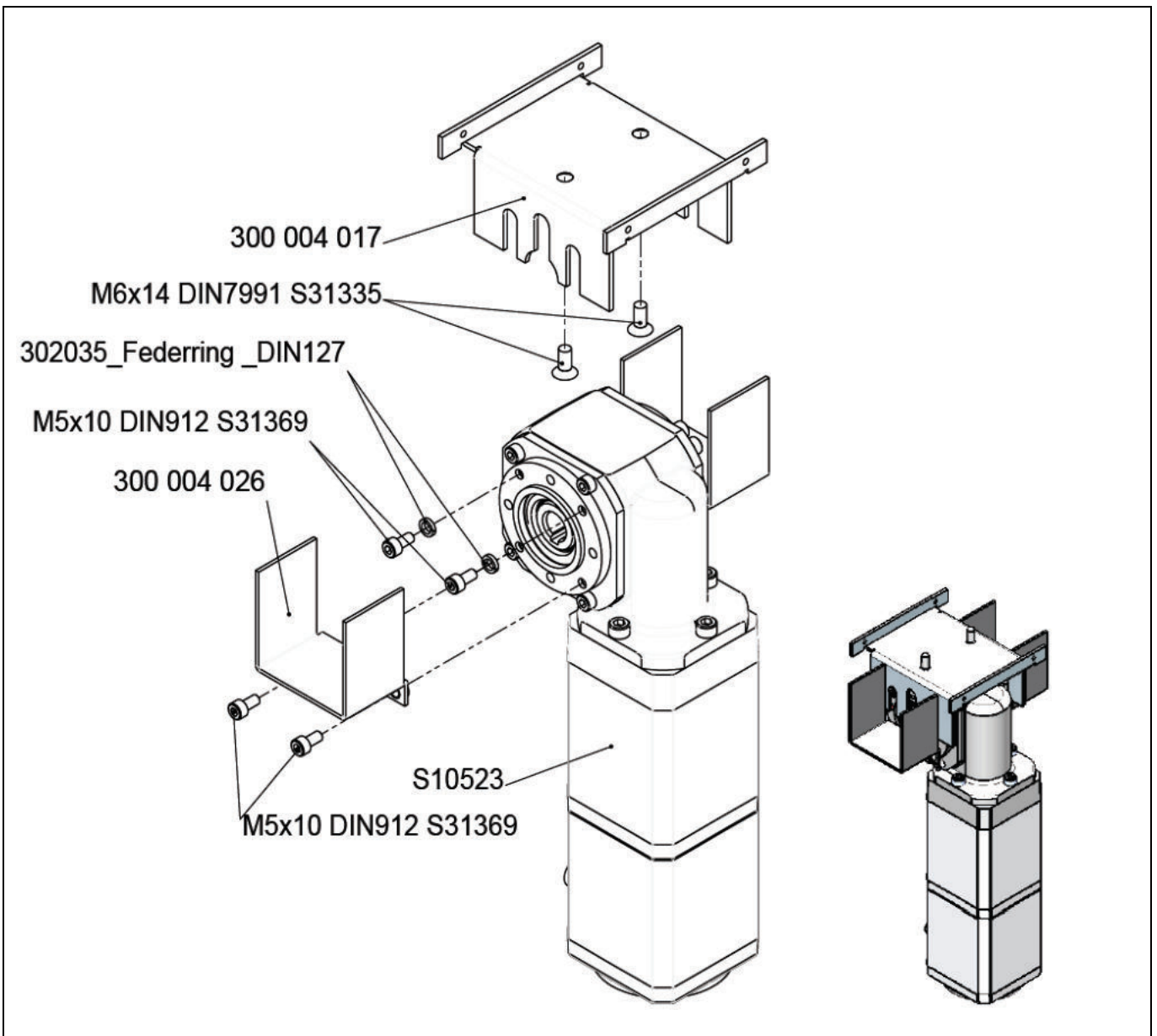





Fig. 12-5: EC WEG motor / hanging – 300 965 001

	Order number	Description	Quantity
	300 004 017	Torque reaction support	1
	300 004 026	Cover	2
	S10523	WEG Softmove motor	1
	S31369	M5x10 DIN912	8
	S31335	M6x14 DIN7991	2
	302035	Spring lock washer DIN127	4

12.1.6 EC WEG motor / fixed – 300 969 001

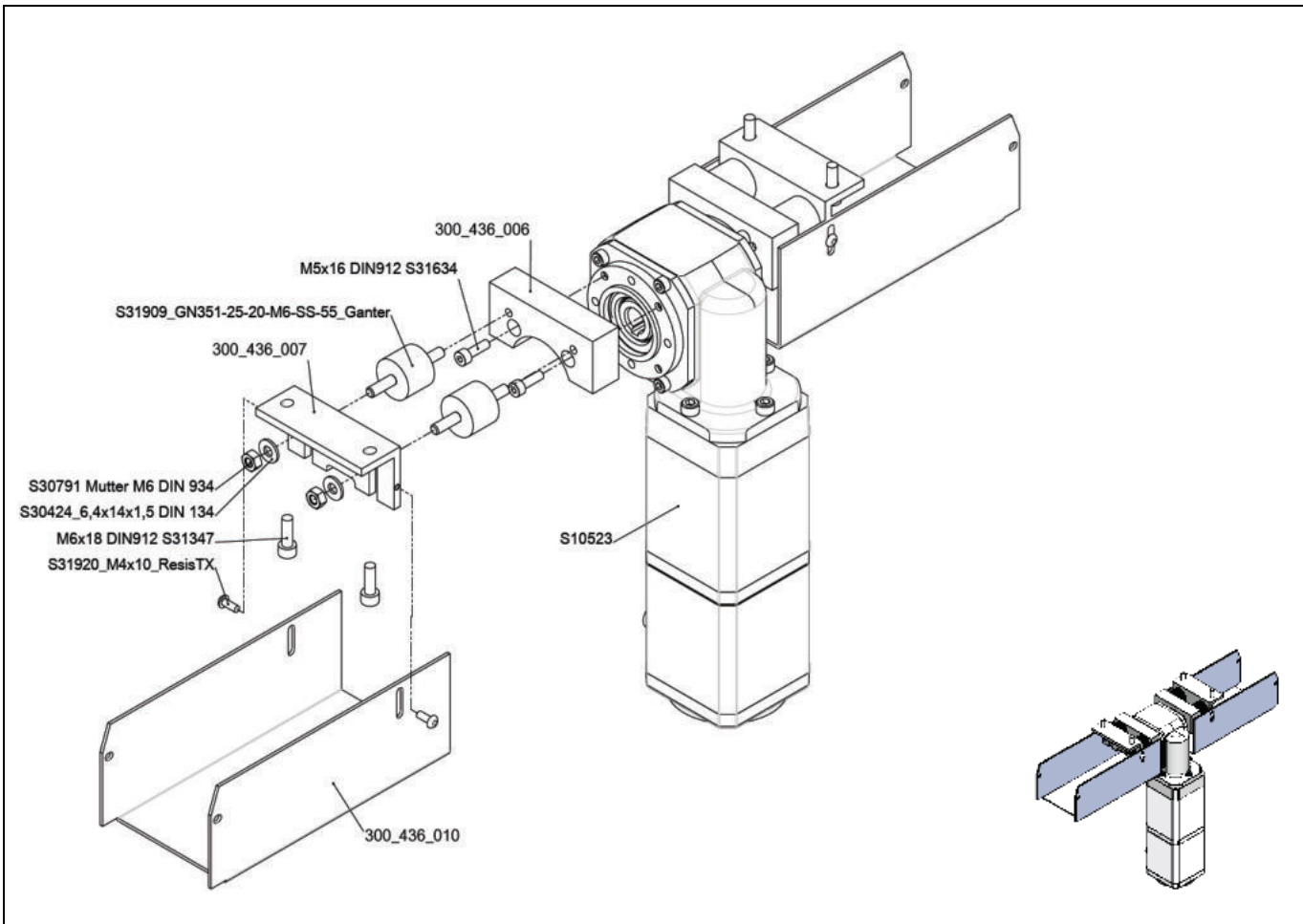











Fig. 12-6: EC WEG motor / fixed – 300 969 001

	Order number	Description	Quantity
	300 436 006	Retaining block	2
	300 436 007	Bracket	2
	300 436 010	Cover	2
	S10523	WEG Softmove motor	1
	S31920	M4x10 Resis TX	4
	S31634	M5x16 DIN912	4
	S31909	GN35 1-25-20-M6-SS-55	4
	S31347	M6x18 DIN912	4
	S30424	Washer 6.4x14x1.5 DIN134	4
	S30791	Screw nut M6 DIN934	4

12.1.7 EC EBM motor / hanging – 300 938 001

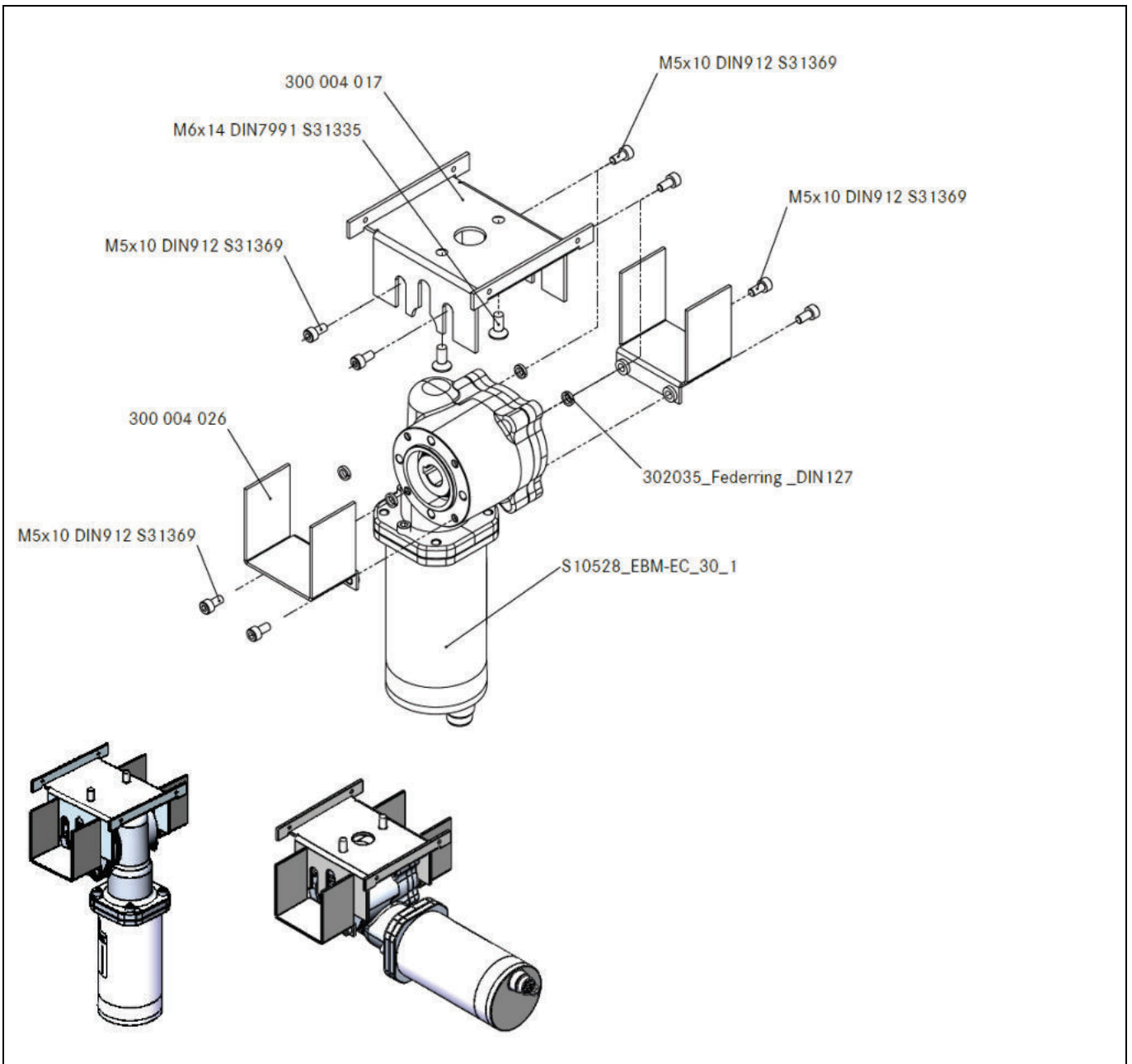







Fig. 12-7: EC EBM motor / hanging – 300 938 001

	Order number	Description	Quantity
	300 004 017	Torque reaction support	1
	300 004 026	Cover	2
	S10528	EC EBM motor with cables 30:1	1
	S31369	M5x10 DIN912	8
	S31335	M6x14 DIN7991	2
	302035	Spring lock washer DIN127	4

12.1.8 EC EBM motor / fixed – 300 970 001

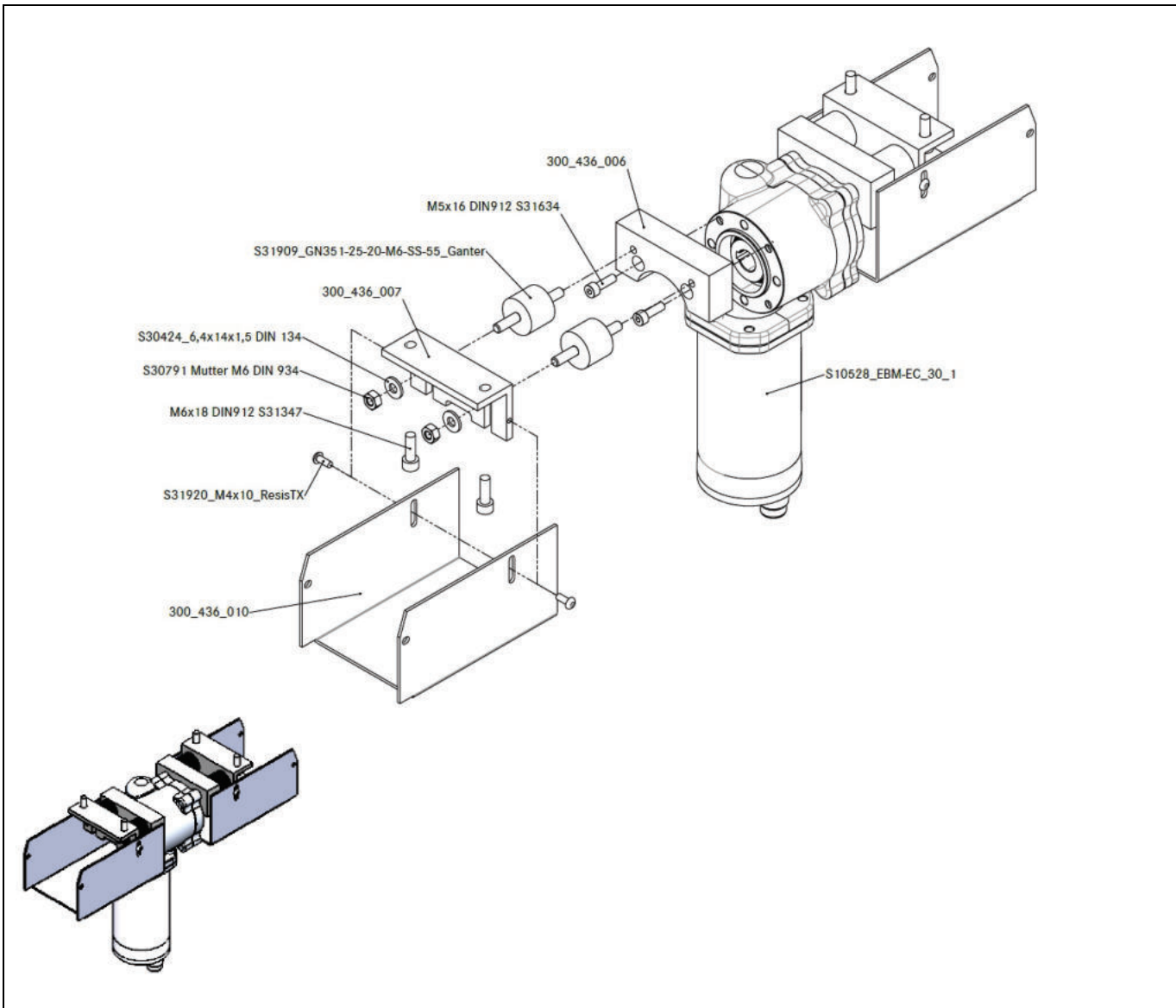











Fig. 12-8: EC EBM motor / fixed – 300 970 001

	Order number	Description	Quantity
	300 436 006	Retaining block	2
	300 436 007	Bracket	2
	300 436 010	Cover	2
	S10528	EC EBM motor with cables 30:1	1
	S31920	M4x10 Resis TX	4
	S31634	M5x16 DIN912	4
	S31909	GN351-25-20-M6-SS-55	4
	S31347	M6x18 DIN912	4
	S30424	Washer 6.4x14x1.5 DIN134	4
	S30791	Screw nut M6 DIN934	4

12.1.9 AC WEG motor / hanging – 300 935 001

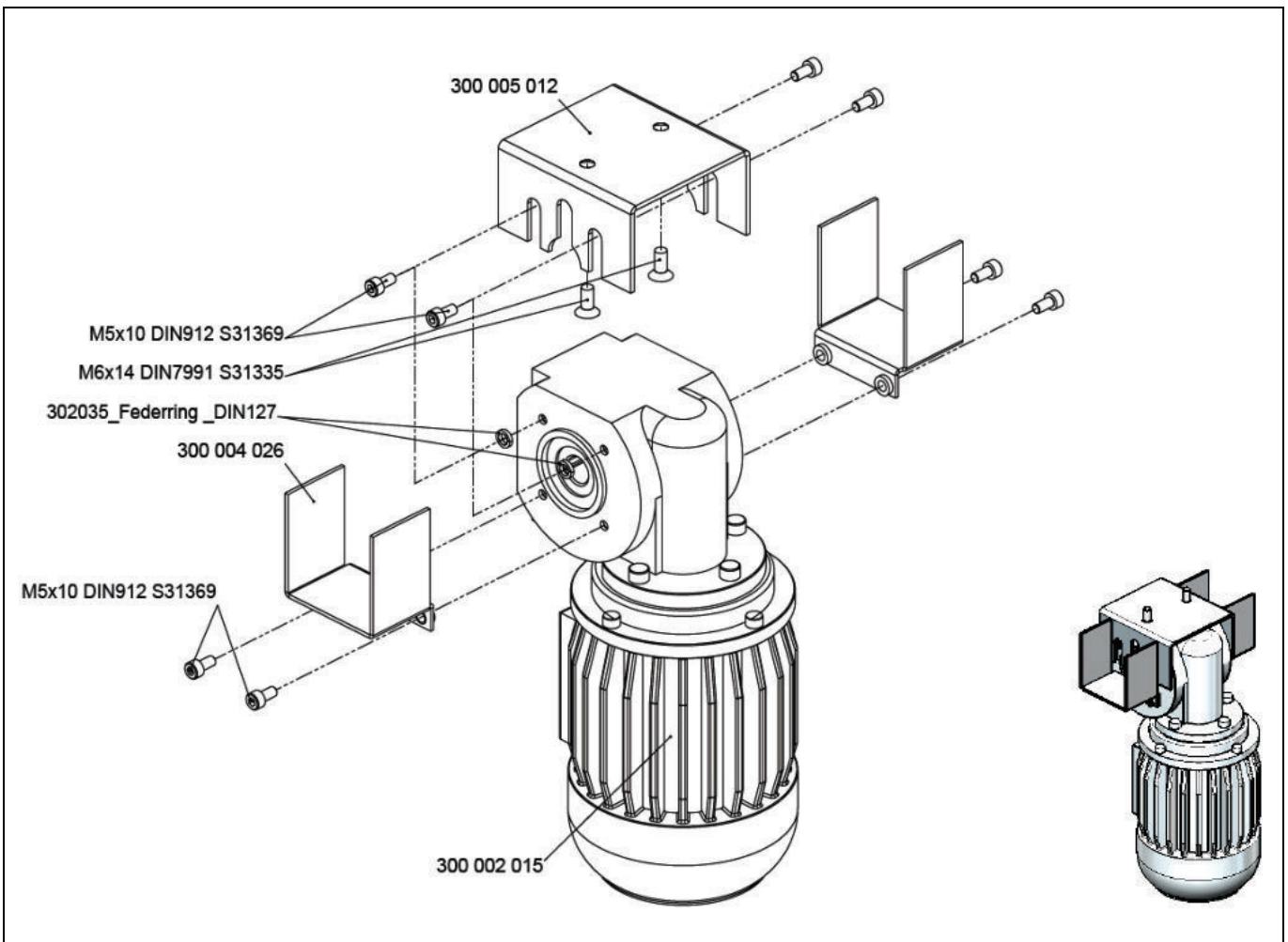







Fig. 12-9: AC WEG motor / hanging – 300 935 001

	Order number	Description	Quantity
	300 002 015	Gear motor	1
	300 004 026	Cover	2
	300 005 012	Torque reaction support	1
	S31369	M5x10 DIN912	8
	S31335	M6x14 DIN7991	2
	302035	Spring lock washer DIN127	4

12.1.10 AC WEG basic motor / hanging – 300 964 001

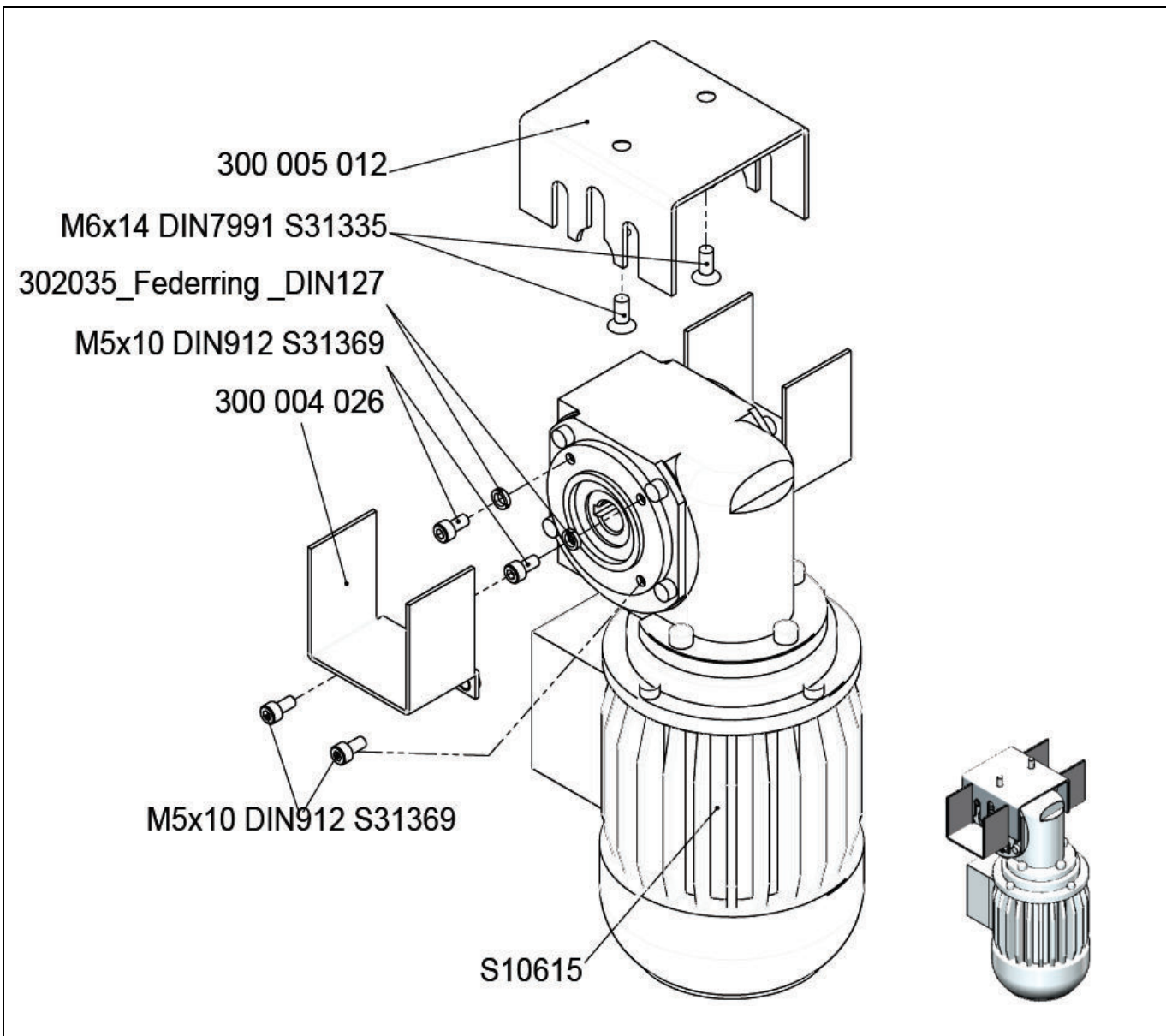







Fig. 12-10: AC WEG motor with terminal board / hanging – 300 964 001

	Order number	Description	Quantity
	300 004 026	Cover	2
	300 005 012	Torque reaction support	1
	S10615	AC WEG motor with terminal box	1
	S31369	M5x10 DIN912	8
	S31335	M6x14 DIN7991	2
	302035	Spring lock washer DIN127	4

12.1.11 EC WEG motor / hanging – 300 936 001

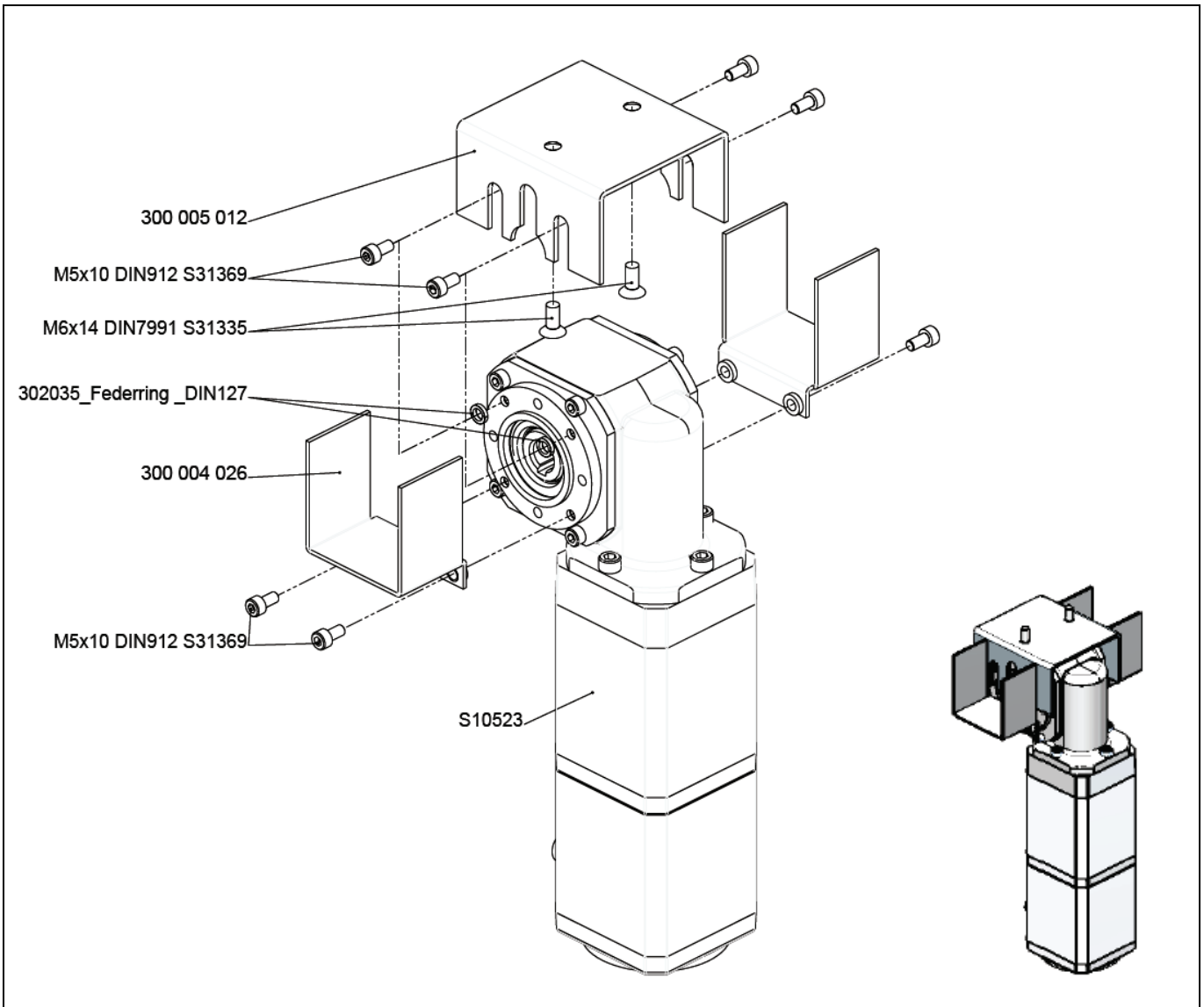







Fig. 12-11: EC WEG motor / hanging – 300 936 001

	Order number	Description	Quantity
	300 004 026	Cover	2
	300 005 012	Torque reaction support	1
	S10523	WEG Softmove motor	1
	S31369	M5x10 DIN912	8
	S31335	M6x14 DIN7991	2
	302035	Spring lock washer DIN127	4

12.1.12 EC EBM motor / hanging – 300 937 001

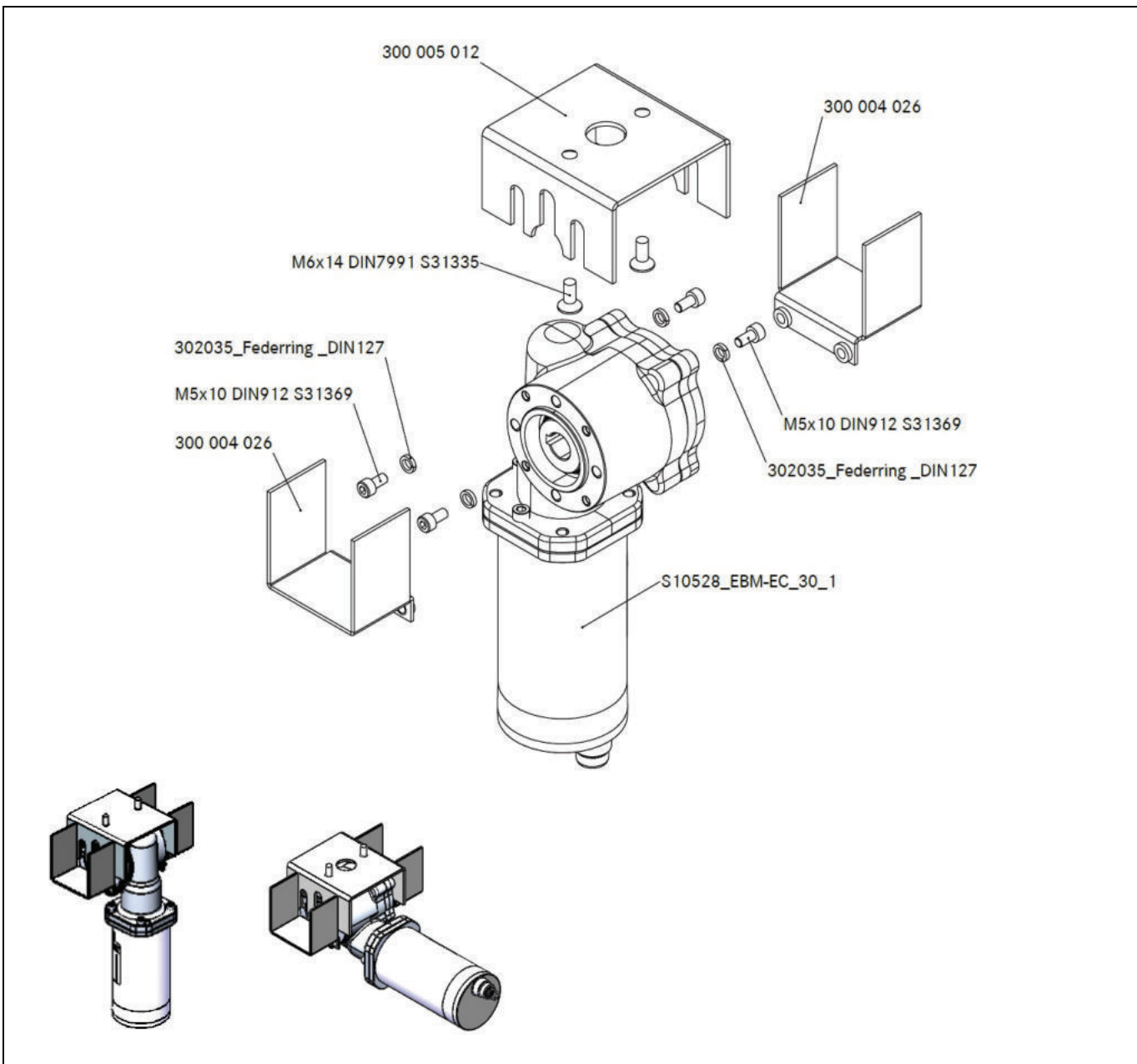





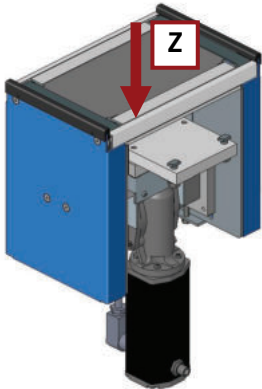

Fig. 12-12: EC EBM motor / hanging – 300 937 001

	Order number	Description	Quantity
	300 004 026	Cover	2
	300 005 012	Torque reaction support	1
	S10528	EC EBM motor with cables 30:1	1
	S31369	M5x10 DIN912	8
	S31335	M6x14 DIN7991	2
	302035	Spring lock washer DIN127	4

13 Appendix

13.1 Technical Specifications

90° transfer unit (SoftMove)	
Lift	15 mm
Sizes available	Any size with a side length between 160 to 400 mm, square or rectangular.
Dimensions	Length and width: 160 to 400 mm (depending on PB and UB)
Transfer unit weight	Approx. 12 kg
Permissible WT loading	 <p>in the Z axis: 120 N (WT + workpiece) if load is centred and under a STEIN working pressure of 4 bar.</p>
Electrical connections (at the power supply unit)	40 Volt power supply (direct current) 24 Volt control voltage
Lift cylinder	∅ 50 mm
Compressed air supply	Festo PUN 6x1, 4 bar Max. 6 bar

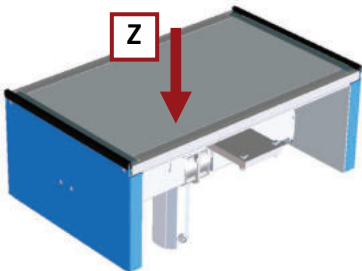
90° Transfer unit (SoftMove) - PB/UB >400mm	
Lift	15 mm
Dimensions	Special dimensions by arrangement with STEIN Automation
Transfer unit weight	Approx. 12 kg
Permissible WT loading	 <p>in the Z axis: 120 N (WT + workpiece) if load is centred and under a STEIN working pressure of 4 bar.</p>
Electrical connection (at the power supply unit)	40 Volt power supply (direct current) 24 Volt control voltage
Lift cylinder	∅ 50 mm
Compressed air supply	Festo PUN 6x1, 4 bar Max. 6 bar

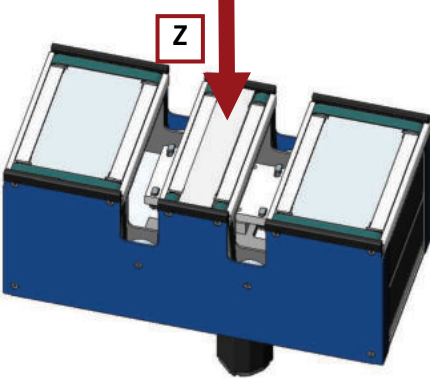
180° Transfer unit (SoftMove) - PB/UB <280mm	
Lift	15 mm
Sizes available	Any size with a side length between 160 to 400 mm, square or rectangular.
Dimensions	Length and width: 160 to 400 mm (depending on PB and UB)
Transfer unit weight	Approx. 18 kg
Permissible WT loading	<div style="display: flex; align-items: center;">  <div style="margin-left: 20px;"> <p>in the Z axis: 120 N (WT + workpiece) if load is centred and under a STEIN working pressure of 4 bar.</p> </div> </div>
Electrical connection (at the power supply unit)	40 Volt power supply (direct current) 24 Volt control voltage
Lift cylinder	∅ 50 mm
Compressed air supply	Festo PUN 6x1, 4 bar , Max. 6 bar

This information reflects the technical status at the time of printing.
STEIN Automation reserves the right to make technical alterations.

STEIN Automation GmbH & Co. KG

Carl-Haag-Straße 26

78054 VS-Schwenningen, Germany

Telephone +49 (0)7720 / 8307-0
info@stein-automation.de

www.stein-automation.de