

## Centring Device

**ZE - 300 246 001**

**ZED - 300 412 001**

STEIN Workpiece Carrier Transport System

## Operating instructions

For the attention all installation, operating and maintenance personnel -  
always keep these instructions by the centring device.

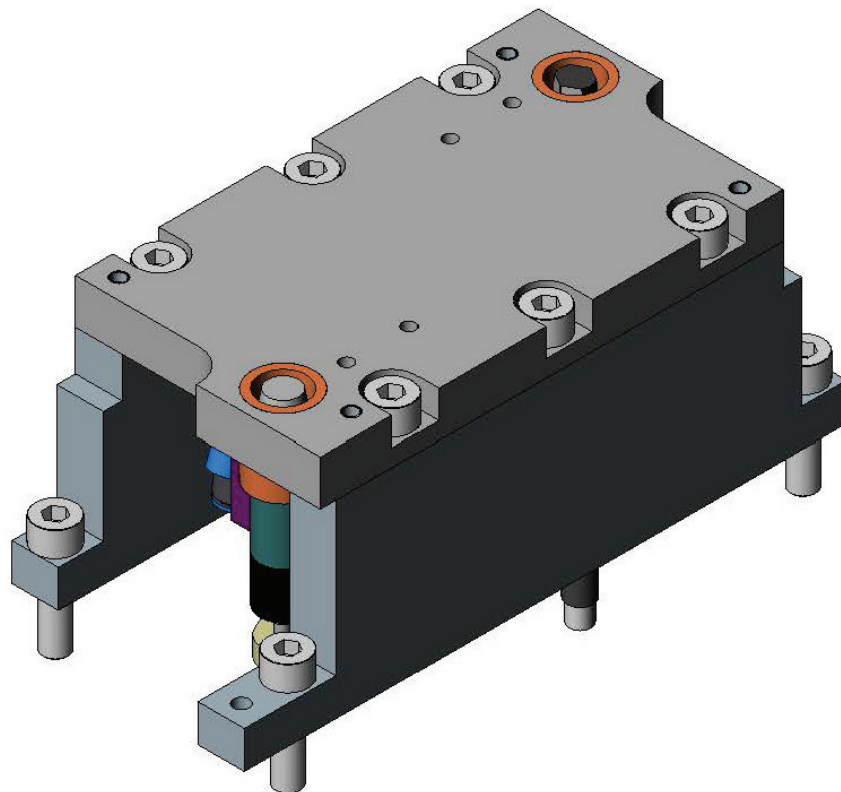

ZED

© by STEIN Automation

The copyright for these documents is reserved by STEIN Automation.

Original language of the documentation: German

These documents may not be altered, amended, reproduced or transferred to third parties without the prior written permission of STEIN Automation.

**STEIN Automation GmbH & Co. KG**

Carl-Haag-Straße 26  
78054 VS-Schwenningen, Germany

Telephone: (+)49 (0)7720 / 8307 – 0

Publication date: December 2018

The right to make changes in design and construction is reserved.

<b>1</b>	<b>Abbreviations and symbols</b> .....	<b>4</b>
1.1	Explanation of safety and warning notices .....	4
<b>2</b>	<b>Introduction</b> .....	<b>5</b>
2.1	Short description.....	6
2.2	Initial inspection.....	7
2.3	Complaints.....	7
2.4	Warranty .....	8
<b>3</b>	<b>Safety information</b> .....	<b>8</b>
3.1	General safety information .....	8
3.2	Appropriate use and liability exclusions .....	8
3.3	Residual danger.....	9
<b>4</b>	<b>Technical description</b> .....	<b>10</b>
4.1	Scope of delivery.....	10
4.2	General .....	10
4.3	Sub-assemblies .....	11
<b>5</b>	<b>Installing the centring device</b> .....	<b>13</b>
5.1	General points.....	13
5.2	Accident prevention .....	13
5.3	Installing the centring device (ZE) .....	14
5.4	Spring force of the thrust pieces.....	17
5.5	Installing the centring device (ZED).....	18
<b>6</b>	<b>Initial operation</b> .....	<b>18</b>
<b>7</b>	<b>Faults</b> .....	<b>19</b>
7.1	Causes of faults.....	19
<b>8</b>	<b>Cleaning and maintenance</b> .....	<b>20</b>
8.1	Cleaning.....	20
8.2	Maintenance .....	21
<b>9</b>	<b>Dimensions sheet</b> .....	<b>21</b>
<b>10</b>	<b>Spare parts</b> .....	<b>22</b>
10.1	300 246 001 Centring device (ZE) .....	22
10.2	300 412 001 Centring device (ZED).....	23
10.3	930 134 001 – Spring loaded roller bar (UB160 PB160-400) .....	24
10.4	930 135 001 – Spring loaded roller bar (UB240 PB160-400) .....	25
10.5	930 136 001 – Spring loaded roller bar (UB320 PB160-400) .....	26
10.6	930 137 001 – Spring loaded roller bar (UB400 PB160-400) .....	27
<b>11</b>	<b>Appendix</b> .....	<b>28</b>
11.1	Technical data .....	28

## 1 Abbreviations and symbols

- Action symbol
- 1 symbol for actions which must be carried out in a specified sequence.
- ⇒ Consequence, result of an action
- Count
- ZE Centring device
- ZED Centring device
- WT Workpiece carrier
- BE Belt element
- BA Operating instructions
- Abb. Figure

### i

This sign indicates information that will allow the centring device to be used more effectively and more economically.

The symbols used in the operating instructions for safety and hazard warnings are described in detail in Chapter 3.

### 1.1 Explanation of safety and warning notices

The following safety signs explain all the situations or actions where danger to life and limb for machine operators or their colleagues exists.

Strictly comply with these instructions and act with particular care in these cases. Pass all safety notices on to all other users.



**DANGER!**

**The symbol with the added designation DANGER describes a directly impending hazards!**

**The hazard results in serious injury to people or even fatalities.**



**WARNING!**

**The symbol with the added designation WARNING describes a potentially impending hazards!**

**The hazard may result in serious injury to people or even fatalities.**



**CAUTION!**

**The symbol with the added designation CAUTION describes a potentially hazardous situation!**

**The hazard can result in injury to people.**

The safety signs appear frequently in the text with a picture to explain what the source of the hazard is.



**CRUSHING HAZARD!**

This symbol gives warning of a location where there is a risk of being crushed.



**HIGH ELECTRICAL VOLTAGE!**

This symbol gives warning of possible electric shock.

It appears for all working and operating procedures that must be followed precisely, in order to avoid injury to personnel or damage to the system through high electrical voltage.

**Other warning signs:**



**ATTENTION!**

This symbol indicates warnings which, if ignored, will cause a hazard to the machine.



**Protective clothing must be worn!**

Wear your personal safety clothing:  
Safety footwear, hard hat, goggles and safety gloves.



**Environmental protection!**

This sign indicates warnings that will help to avoid harming the environment.

## 2 Introduction

The safety of all persons who come into contact with the centring device depends fundamentally on knowing how the centring device functions. Therefore:

**Read these operating instructions before using the device for the first time!**

These operating instructions contain important information that will ensure the correct, economical and safe operation of your centring device.

## 2.1 Short description

Centring devices from STEIN-Automation are optional modules for the workpiece carrier transport system from STEIN-Automation.

In accordance with the multi-faceted requirements profile of these installations and the different workpiece carrier sizes we offer two different standard variants for these installations:

- a centring device (ZE) for a maximum centring accuracy of the workpiece carrier of 0.15 mm
- a centring device (ZED) for a maximum centring precision of the workpiece carrier of 0.02 mm

In conjunction with the transport system, this device allows:

- exact positioning of workpiece carrier (and therefore of the workpieces located on them), and/or
- workpiece carrier elevation and support while power transfer operations are carried out on a workpiece.

Other advantages of these devices are that the belt element is not under tension during workpiece machining and therefore wear on the belts is minimised.

Fig. 2-1:  
Centring device (ZE)

- 1 Centring rail
- 2 Anvil plate
- 3 Sprung slide rail

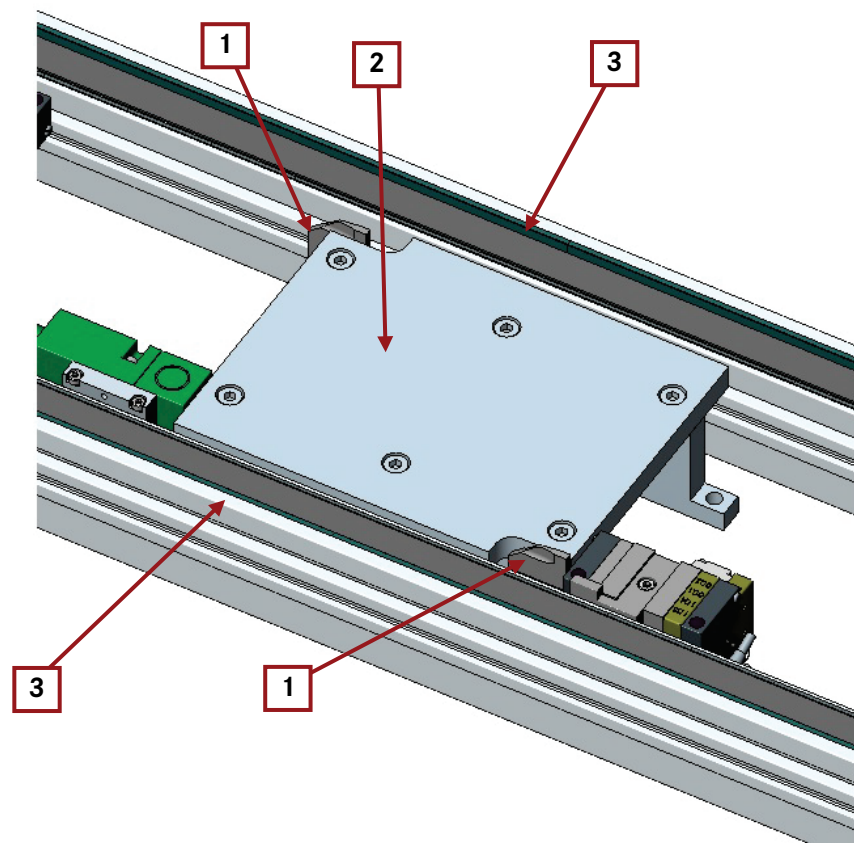
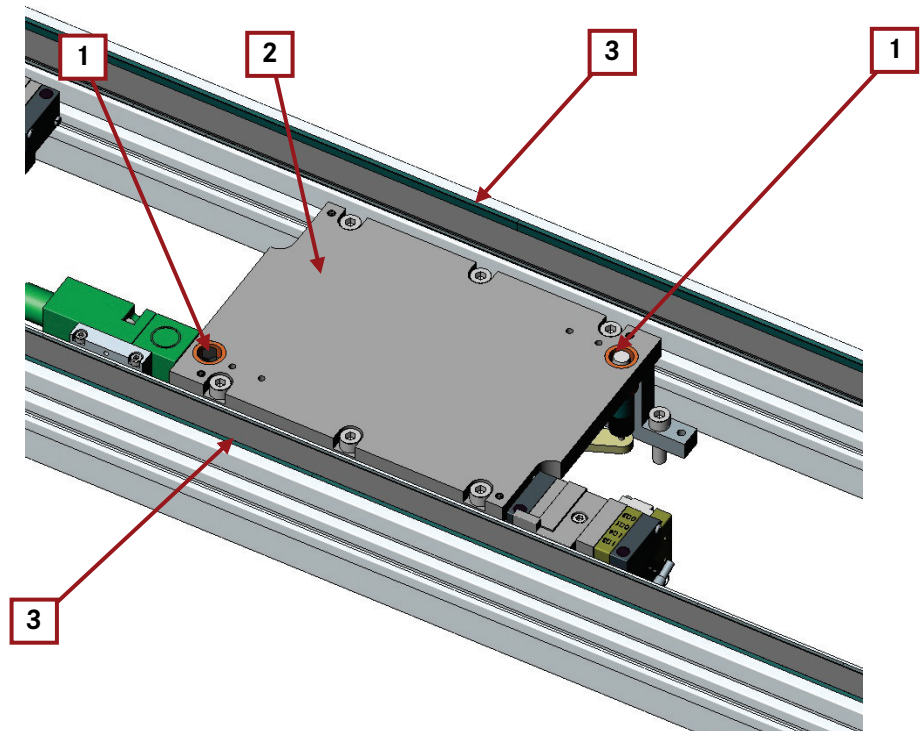

Fig. 2-2:  
Centring device (ZED)  
Exemplary representation

- 1 Retaining bolt
- 2 Anvil plate
- 3 Sprung slide rail



## 2.2 Initial inspection

- Unpack all the components supplied!



### Environmental protection!

Dispose of all packaging material in an environmentally responsible way.

Then carry out an initial inspection.

Check that:

- all components detailed on the delivery note have been supplied
- components have not been damaged during transport or are defective.

## 2.3 Complaints

In order for claims for damages caused in transit to be accepted, follow this procedure:

- Inform the freight company.
- Draw up a damage report giving the following details
  - Name and address of recipient
  - Item or order number
  - A description of the damage.
- Send components, if possible in their original packaging, with the damage report, back to the manufacturer.

## 2.4 Warranty

For the centring device and its spare parts we grant the legal guarantee period or rather the defined guarantee period in the contract, starting with the day of delivery.

During this warranty period we will replace any components defective in manufacture or materials free of charge.

STEIN Automation's general warranty and warranty conditions apply.

## 3 Safety information

### 3.1 General safety information

- Centring units from STEIN Automation are high quality products, manufactured to recognised technical specifications.  
The centring units left the manufacturing plant in a perfectly safe technical condition!
- All versions of the centring units comply with the requirements of UVV, the German accident prevention regulations.
- To maintain this situation, installation staff, users and service technicians must observe the notices and warnings contained in these operating instructions.
- Centring units must only be installed and repaired by authorised personnel who have been trained by STEIN Automation.
- Only genuine spare parts from STEIN Automation may be used when carrying out repairs to the centring units.

### 3.2 Appropriate use and liability exclusions

The centring unit may only

- be used in workpiece carrier transport system belt systems,
- for suitable workpieces with the permitted dimensions and weights,
- only for the intended purpose of the model,
- indoors,
- in dry areas,
- in areas where there is no risk of an explosion,
- in an environment that is free of oil and shavings.

The centring accuracy and loading capacity of the installation can be taken from Chapter 11.1 Technical data.

#### **i**

Unauthorised interventions, alterations or repairs carried out on the centring device invalidate the guarantee.

STEIN Automation accepts no liability for damage caused by unauthorised interventions, changes or repairs!



### 3.3 Residual danger

The centring device is manufactured using state-of-the-art technology and to recognised safety standards. Nevertheless, its use can lead to dangerous situations for users or third parties or to impairments of the system and other material assets.

During the transport of workpiece carrier and products, amongst others, the following injuries can result:

- Jamming occurring between the workpiece carrier and guide centring device.



#### Only for the version: centring device (ZED):

There is a crushing hazard on the centring device between the lever and the buffer. This must be reduced by attaching protective covers and warning signs. See note in Chapter 4.1

Fig. 3-1:  
Possible  
crushing points

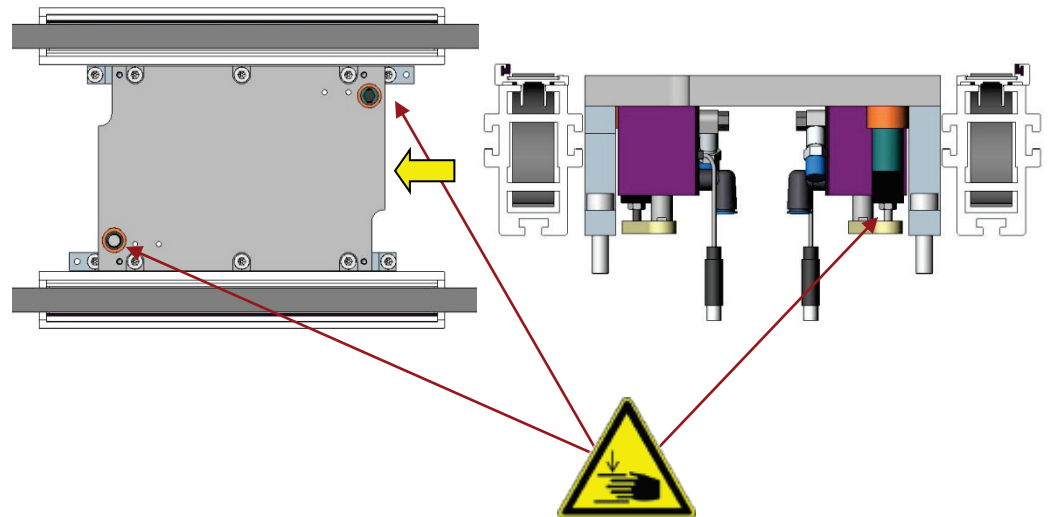

**i**

The warning signs must be attached by customers immediately in the area of the centring device.

	Order number	Description	Number	WP	SP
	S31798	Sign warning against a risk of injuring the hands SL 25 mm	2		x

## 4 Technical description

### 4.1 Scope of delivery

The centring devices can be supplied for workpiece carrier sizes from 160x160 to 400x400 mm (infinitely), also in a rectangular form.



**The centring devices are mounted complete and are supplied ready for connection - but without a protective cover! These should be adapted by the customer to the specific requirements and then mounted.**

The sprung slide rails are also in the scope of delivery.



**WARNING!**

The scope of delivery of the centring devices does not include a control system and also no stopper! These must be ordered separately.

### 4.2 General

The centring devices can be installed in the longitudinal and transverse sections. The solenoid valves and limit switches must be actuated by the automatic station.



**WARNING!**

The slide rails or roller cassettes of the belt elements should be replaced by sprung slide rails in the area of the centring device.

Sprung slide rails prevent the transport belts being jammed between the workpiece carrier and the belt profile.



**WARNING!**

The centring devices must not be mechanically connected with the workpiece carrier transport system to absorb forces from assembly processes.

The forces arising in the Z-axis must be taken up by the substructure of the centring device (base plate)!

This plate should be dimensioned by the customer and then mounted.

Any high forces arising at specific points should be transferred over floating mushroom heads in the workpiece carrier. Here the support plate of the centring device is also supported at the pressure points with columns on the base plate (see Fig. 4-2:

## 4.3 Sub-assemblies

### 4.3.1 Centring device (ZE)

Fig. 4-1:  
Centring device (ZE)

- 1 Centring rail
- 2 Anvil plate
- 3 Sprung slide rail
- 4 Base plate  
(on the customer side)

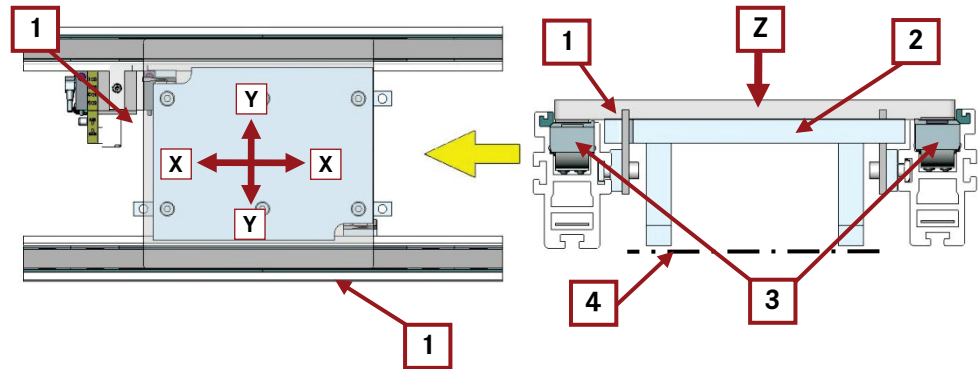

#### Function.

Stopping of the workpiece carrier by the stopper with centring of the centring rail.

The slide rail pushes the drive belt downwards by spring force when force is applied in the Z-axis. The workpiece carrier then lies on the anvil plate which is supported by the base plate. This prevents drive belts getting clamped.

The base plate is not included in the scope of delivery of the centring device.

#### Use.

In STEIN workpiece carrier transport systems (STEIN 300) for positioning workpiece carriers.

For manual and automatic workplaces for which a precise location of the workpiece carrier is required and high forces arise in the Z-axis.

#### Positioning accuracy.

Workpiece carrier positioning accuracy:

- X axis +/- 0.22 mm
- Y axis +/- 0.15 mm
- The location of the workpiece carrier can change in the Z-axis due to the bonding surface of the belt by up to 0.5 mm until the workpiece carrier is pressed onto the anvil plate.

Fig. 4-2:  
Support forces (optional)

- 1 Workpiece carrier
- 2 Floating bolt
- 3 Anvil plate
- 4 Column
- 5 Base plate  
(on the customer side)

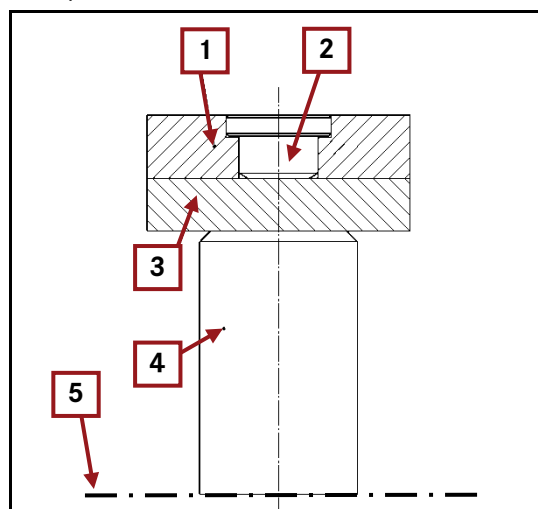

#### Remarks

The area around the sprung sliding rail must be predetermined in the belt element. Any high forces arising at specific points should be transferred over floating bolts in the workpiece carrier. Here the support plate of the centring device is also supported at the pressure points with columns on the base plate (on the customer side)

For the spring force of the thrust pieces see page 16.

### 4.3.2 Centring device (ZED)

Fig. 4-3:  
Centring device (ZED)

- 1 Centring pin
- 2 Anvil plate
- 3 Sprung slide rail
- 4 Base plate  
(on the customer side)

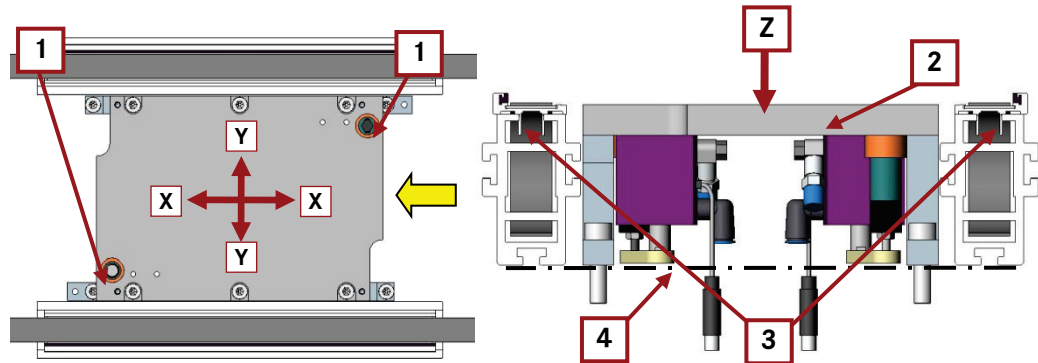

#### Function.

**Stopping of the workpiece carrier by the stopper with centring by the moving up centring pin.**

The slide rail pushes the drive belt downwards by spring force when force is applied in the Z-axis. The workpiece carrier then lies on the anvil plate which is supported by the base plate. This prevents drive belts getting clamped.

#### Use

In STEIN workpiece carrier transport systems (STEIN 300) for positioning workpiece carriers.

For automatic workplaces for which a precise location of the workpiece carrier is required and high forces arise in the Z-axis.

#### Positioning accuracy.

Workpiece carrier positioning accuracy

- +/- 0.2 mm in the X and Y axes
- the location of the workpiece carrier can change in the Z-axis due to the bonding surface of the belt by up to 0.5 mm until the workpiece carrier is pressed onto the anvil plate.

Fig. 4-4:  
Support forces  
(optional)

- 1 Workpiece carrier
- 2 Floating bolt
- 3 Anvil plate
- 4 Column
- 5 Base plate  
(on the customer side)

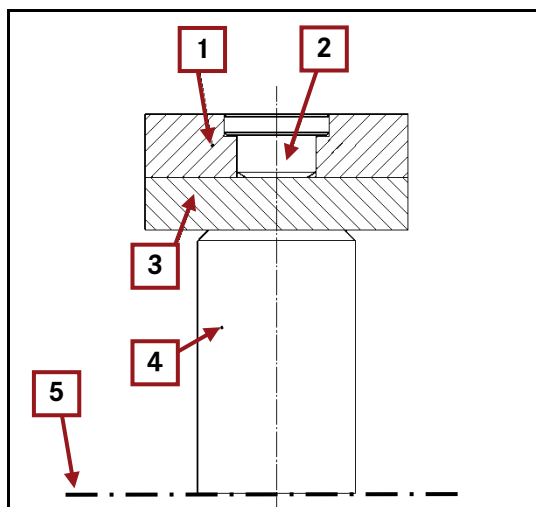

#### Remarks

The area around the sprung slide rail must be predetermined in the belt element. Any high forces arising at specific points should be transferred over floating bolts in the workpiece carrier. Here the support plate of the centring device is also supported at the pressure points with columns on the base plate (on the customer side)

For the spring force of the thrust pieces see page 16.

## 5 Installing the centring device

### 5.1 General points

The following description of the installation refers to assembly of the centring devices. General information for the assembly is given.

Attachment of the centring device to its mounting situation must be performed by the operating company or by STEIN specialist personnel.



You will find the respective dimensional and installation drawings in the following.



**WARNING!**

The centring devices must not be mechanically connected with the workpiece carrier transport system to absorb forces from assembly processes.



**WARNING!**

On operating stations which generate chips (for example drilling or thread-cutting machinery), covers should be installed to avoid chips or cooling fluid coming into contact with the belt element or the centring device.

Installation is subdivided into:

- Adaptation of the processing (machining) station,
- installation of the sprung slide rails in the belt element,
- installation of the centring device,
- assembly of stoppers\* and sensors,
- fitting the safety equipment (accident prevention) and
- connection of the electrical and pneumatic components to the electrical mains supply and the compressed air network.



Installation of the stopper/centring rails can be found in the documentation:

- Technical description
- Stopping devices (SE) for the STEIN workpiece carrier transport system

### 5.2 Accident prevention

Before you begin with the installation:

- Disconnect the workpiece carrier transport system concerned and the machining station from the electrical mains supply and the compressed air network!
- Put up warning signs to prevent the system being started up while installation work is being done!
- Remove any workpiece carrier located on the respective belt elements.

## 5.3 Installing the centring device (ZE)



Please note here the dimension sheet in Chapter 9.

Use of a ZE requires:

- provision by the customer of the base plate for mounting the ZE,
- replace the sliding rails,
- installation of sprung slide rails and
- installation of a stopping device.



Please note the documentation:

- Technical description
- Stopping devices (SE) for the STEIN workpiece carrier transport system

The ZE can be inserted at any desired point in the belt element (in as far as the sprung slide rails were mounted at the respective position).

### 5.3.1 Provision of the base plate

The centring device is mounted between the guide profile of the belt element on a base plate.



**WARNING!**

The ZE must not have any mechanical connection to the belt element.

The forces applied to the workpiece in the Z-axis by the machining station must be led away over the workpiece carrier, the anvil plate of the centring device and the base plate to their substructure.

### 5.3.2 Replacing the sliding rails

The drive belts on the transport system slide over slide rails or roller cassettes which are embedded in the guide profile of the belt element.

The forces applied to the workpiece in the Z-axis by the machining station, and therefore also on the belts, increases the friction between the belts and the rails and lead to rapid wear on the belts or the belt drive is blocked.

Therefore replace non-sprung slide rails or rollers with sprung slide rails in the area of a machining station in which forces > 100 N are exerted on the workpiece in the Z-axis!

The pressure is taken up by the base plate and the belts can be passed with low loading between the workpiece carrier and sprung slide rails.



The procedure for workpiece carrier transport system belt systems with slide rails and that for systems with roller cassettes is quite different.

Please note further description in Chapter 5.3.3 and 5.3.4.

### 5.3.3 Installation of sprung slide rails with roller cassettes

Fig. 5-1:  
Install sprung slide rails

- 1 Transport belt
- 2 Roller cassettes
- 3 Sprung slide rails
- 4 Guide profile
- 5 Guides
- 6 Guide rail

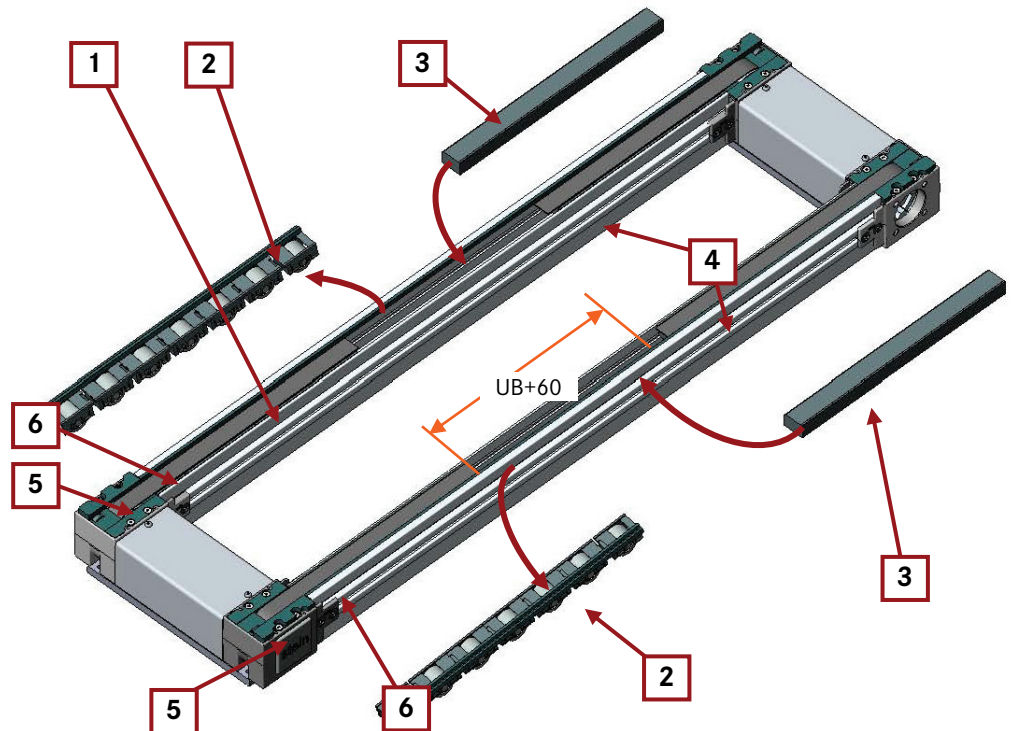

- Determine the area on the belt element in which the machining station and the centring device should be inserted.
- Dismantle the guides.
- Pull the guide rails out of the guide profile.
- Lift a transport belt into this area and pull it somewhat to the side.

Do not overstretch the belt!



**WARNING!**

- Using a screwdriver pry the respective roller cassettes out of the guide profile (over a minimum width of UB+60).
- Place the sprung slide rail in the gap between the roller cassettes.

Do not jam the sprung slide rail.



**WARNING!**

- Lay back the belt on the sprung slide rail.
- Change the opposing roller cassettes using the same procedure.

### 5.3.4 Installation of sprung slide rails in the belt element with a guide profile

Fig. 5-2:  
Install sprung slide rails

- 1 Transport belt
- 2 Removed slide rail
- 3 Sprung slide rails
- 4 Guide profile
- 5 Guides
- 6 Guide rail

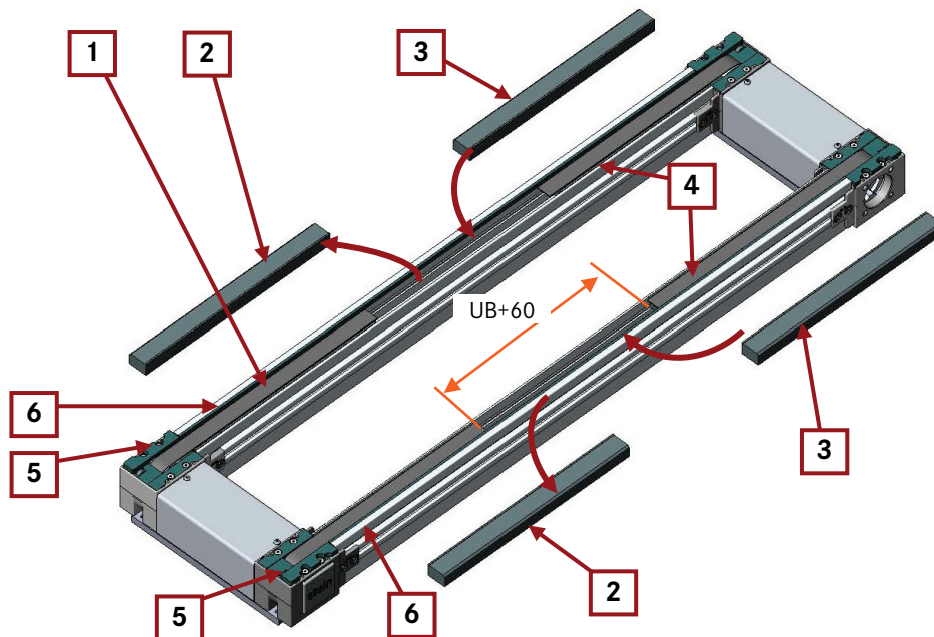

- Determine the area on the belt element in which the machining station and the centring device should be inserted.
- Dismantle the guides.
- Pull the guide rails out of the guide profile.
- Lift a transport belt into this area and pull it somewhat to the side.

Do not overstretch the belt!



**WARNING!**

- Place a screwdriver in the gap between two slide rails and pry out the rail to be replaced out of the guide profile until you can take hold of it and pull it out completely.
- Remove a piece from the removed slide rail (in the respective position) by sawing (UB+60) which should subsequently be replaced by the sprung slide rail.
- Remove burr on the sawing edges of the piece of unsprung slide rail which is again inserted into the belt element.
- Place the sprung slide rail in the gap between the pieces of unsprung slide rail.

Do not jam the sprung slide rail.



**WARNING!**

- Push the guide rails into the guide profile again.
- Mount the guides.
- Lay back the belt on the sprung slide rail.
- Change the opposing slide rail using the same procedure.



## 5.4 Spring force of the thrust pieces

Fig. 5-3:  
Sprung slide rails

- 1 Rail
- 2 Slide rail
- 3 Sprung thrust piece

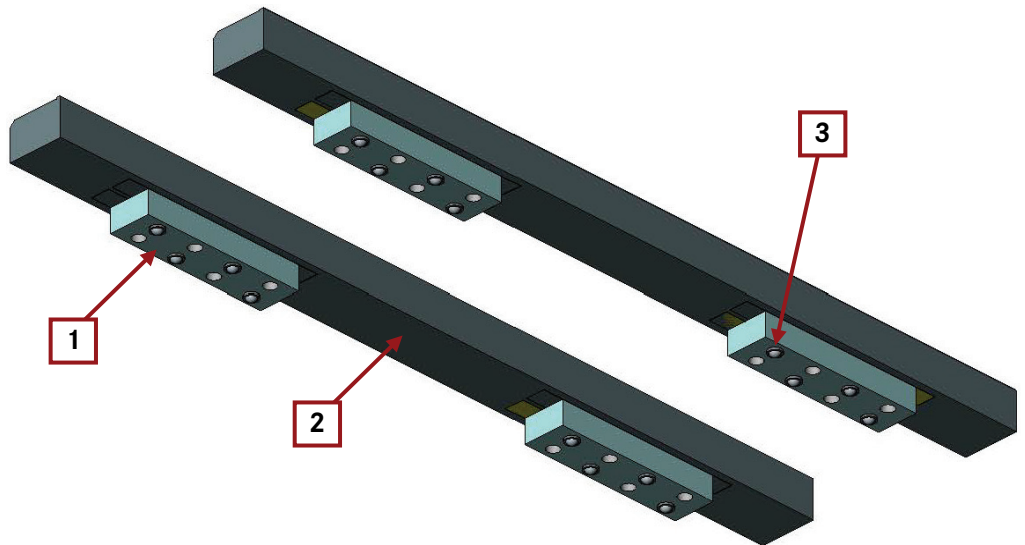

**i**

Installation of sprung slide rails with roller cassettes see Chapter 5.3.3.

Installation of sprung slide rails in the belt element with a guide profile see Chapter 5.3.4.

Fig. 5-4:  
Sprung slide rail  
Spring force  
300 519 001

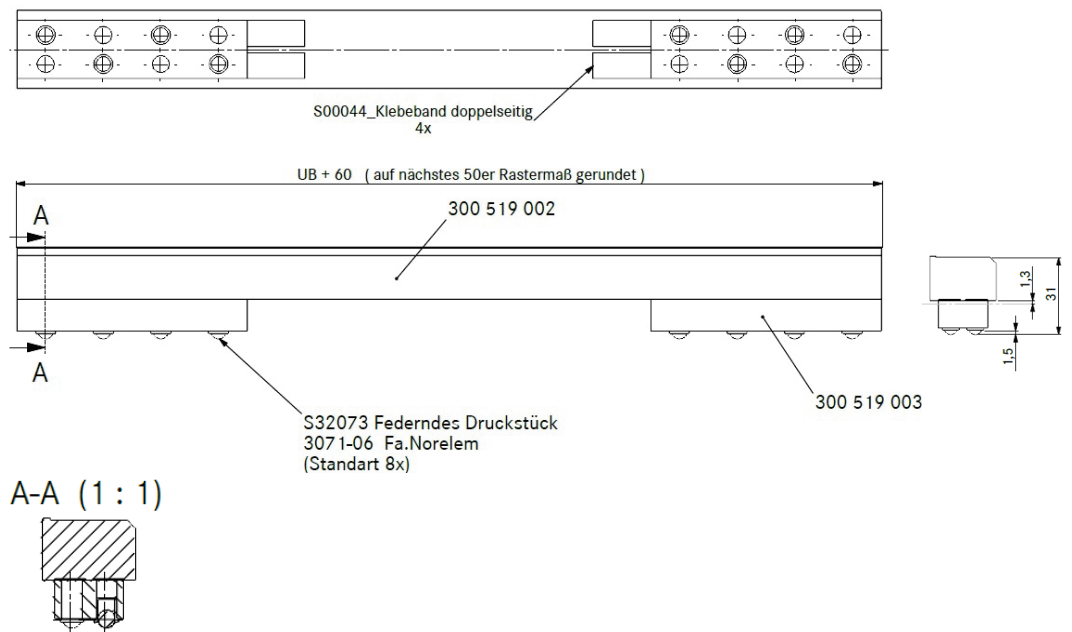

The spring force can be increased using additional thrust pieces.

For a starting pressure of 6N and a stroke of 0.8 mm, the spring force is about 9N per thrust piece.



**WARNING!**

**The number of thrust pieces must not be altered without consultation with the Technical Sales Department at STEIN Automation!**

## 5.5 Installing the centring device (ZED)

Installing the centring device (ZED - for a higher positioning accuracy) is identical to the procedure for the ZE.



Please note here the dimension sheet in Chapter 9.

## 6 Initial operation

Carry out the following checks before initial operation:

- Are all the electrical cables undamaged?
- Are all the electric and pneumatic leads / hoses correctly connected?
- Are all the mechanical components tightly fastened in place?
- Have all tools and other equipment been cleared from the transport area?
- Has all the safety equipment been installed and is it working correctly?
- Are all workpiece carriers in the correct position or is there a workpiece carrier jam present?

Once you have carried out all these checks, you can continue with the initial operation.

- Switch on the Transport System and its associated processing stations and carry out a trial run.
- Check the functions of the individual elements and processing stations as well as the proper (programmed) interaction of the complete system.
- Check the safety equipment is functioning correctly.



**WARNING!**

**Only release the transport system to be used after you have carried out a successful trial run!**

## 7 Faults



**WARNING!**

**When faults, malfunctions or damage affecting safety occur, immediately push the EMERGENCY STOP button to switch the transport system off!  
Have the cause of the malfunction identified and the problem fixed by authorised personnel!**

### 7.1 Causes of faults

Fault	Cause	Solution
The centring pins do not move upwards or do not settle	Failure of the electrical mains or compressed air system	<input type="checkbox"/> Check the electrical mains supply and compressed air supply for the system.
	Variable power supply or loss of pressure of the compressed air	<input type="checkbox"/> Check the electrical mains supply and compressed air supply for the system.
	Failure of the transport system control or the machining station.	<input type="checkbox"/> Check the subordinate control for the station
	Damage to cables or compressed air lines	<input type="checkbox"/> Check the cable and line routing for the installation
	Faulty assembly or connections	<input type="checkbox"/> Check the installation situation of the device
	Faulty programming	<input type="checkbox"/> see software description WTSWIN



**WARNING!**

**Only release the transport system to be used after you have carried out a successful trial run!**

## 8 Cleaning and maintenance

### 8.1 Cleaning

Depending on the ambient conditions of the transport system, the control console gets dirty

Clean the centring device regularly!

How frequently this is done depends on the degree of soiling.

**i**

Cleaning does not mean the transport system needs to be dismantled.



**DANGER!**

**DANGER!**

**Through the unexpected start up of the transport system.**



**DANGER!**

**HIGH ELECTRICAL VOLTAGE!**

**Electric shock hazard!**

- 1 Before carrying out any installation or repair work, disconnect the relevant workpiece carrier transport system from its electrical power supply!
- 2 Put up warning signs to prevent the system being started up while installation and repair work is being done!
- 3 Remove the workpiece carrier from the transport system!



**Protective clothing must be worn!**

When cleaning, wear goggles, safety gloves and, if necessary, a dust-mask.

Only use a vacuum cleaner to remove dust, shavings and other particles.

- 4 Remove dust, chips and other particles with a vacuum cleaner.
- 5 Clean dirty surfaces with a soft, lint free cloth, lightly dampened with cleaning fluid.



**WARNING!**

When cleaning, do not use any abrasive, corrosive or scouring cleaning fluids or cleaning materials.

Avoid fluid getting into the components of the system or of the processing stations.

**i**

STEIN Automation recommends the industrial cleaner from Würth, Article no.: 893140 or Arecal Clean manufactured by RECA Norm, article no.: 0895014500.



**Environmental protection!**

Dispose of waste material and used cleaning cloths in an environmentally responsible way.

## 8.2 Maintenance

Centring units require no maintenance.

## 9 Dimensions sheet

Fig. 9-1:  
Dimensions sheet  
Centring device (ZE)

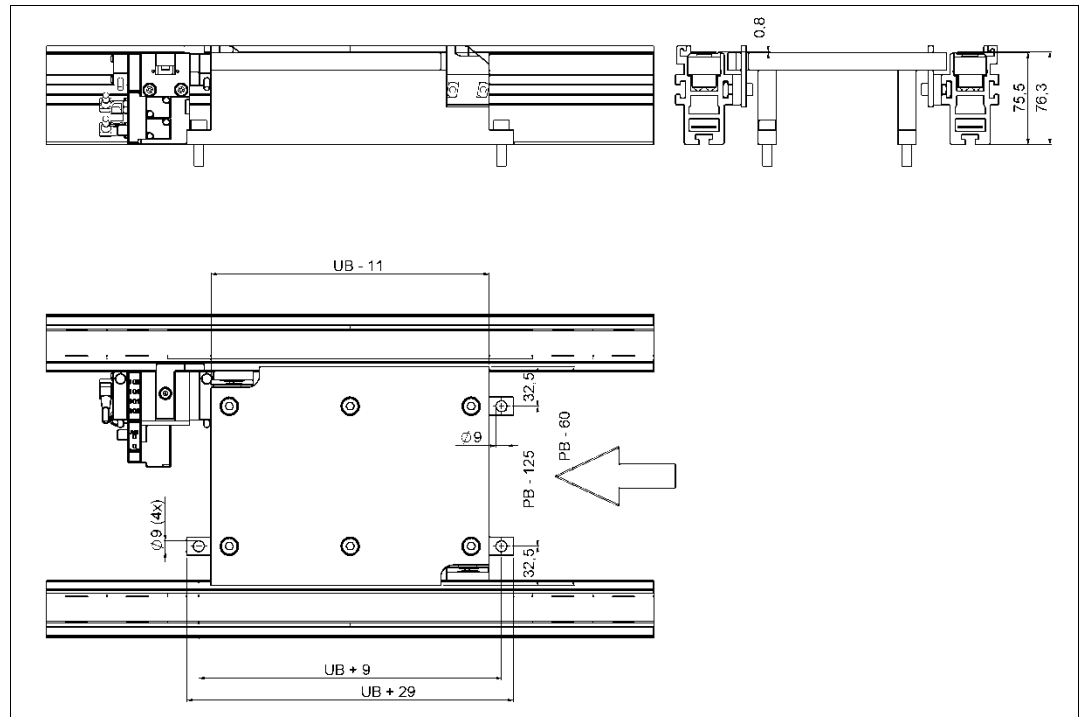
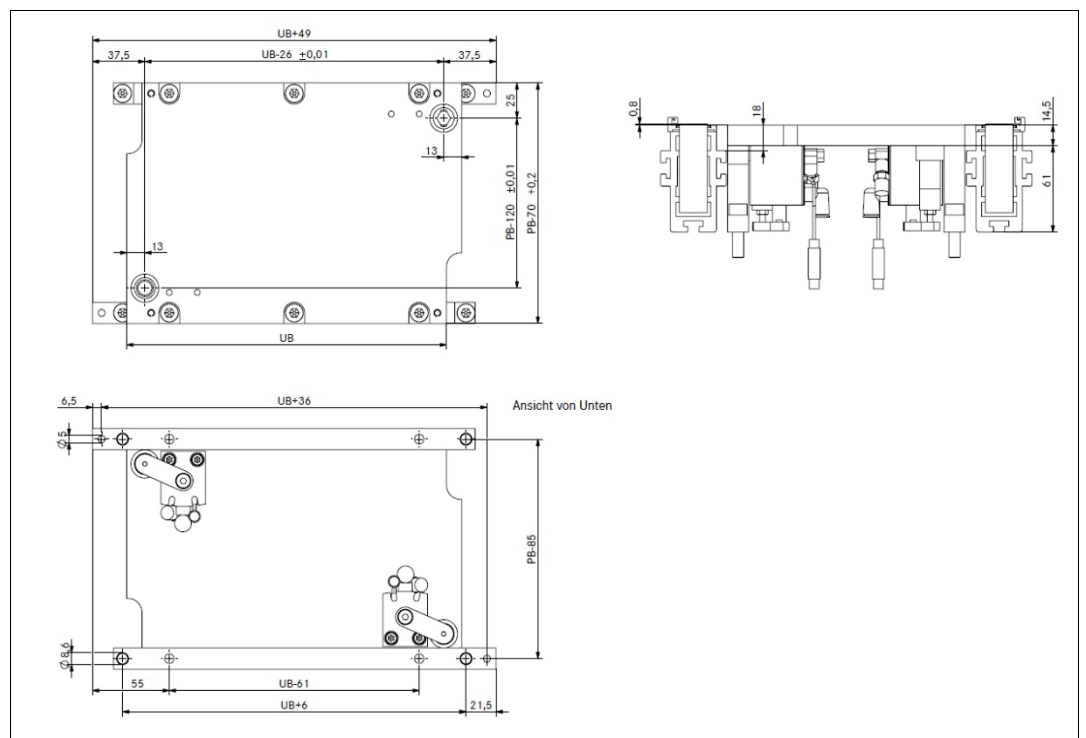

Fig. 9-2:  
Dimensions sheet  
Centring device (ZED)



## 10 Spare parts

### 10.1 300 246 001 Centring device (ZE)

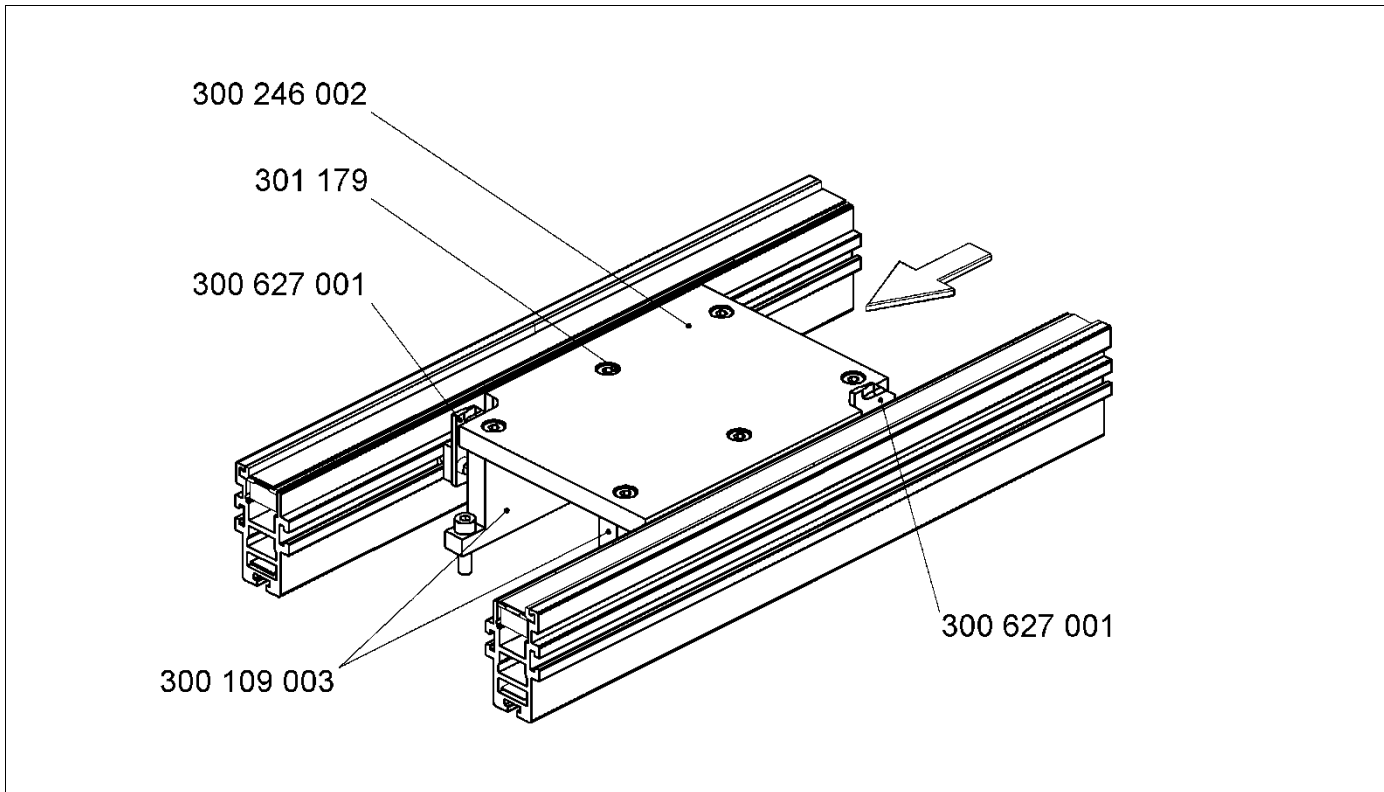

Fig. 10-1: Centring device (ZE)

Order number	Description	Number
300 627 001	<b>Centring rail complete</b>	1
300 109 003	<b>Support plate</b>	2
300 246 002	<b>Plate</b>	1
301 179	<b>Screw</b>	6

## 10.2 300 412 001 Centring device (ZED)

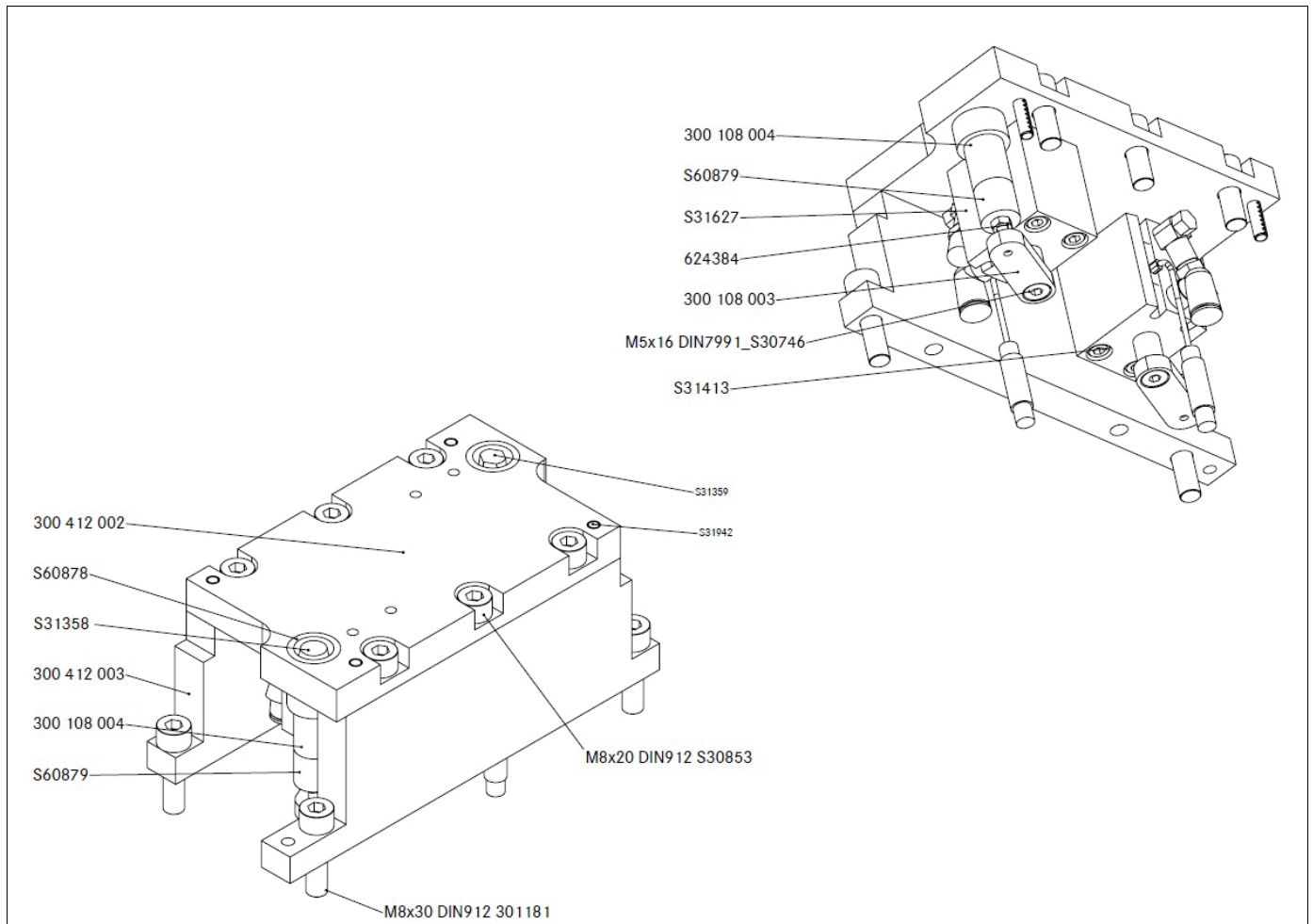

Fig. 10-2: Centring device (ZED)

Order number	Description	Number
300 412 002	<b>Plate ZED</b>	1
300 412 003	<b>Support plate ZED</b>	2
300 108 003	<b>Lever</b>	2
300 108 004	<b>Guide bolt</b>	2
S60878	<b>Guide bush</b>	2
S31358	<b>Retaining bolt</b>	1
S60879	<b>Buffer from the company Reiff</b>	2
S30853	<b>M8x20 DIN9 12</b>	6
S31627	<b>Festo cylinder complete</b>	2
S30746	<b>M5x16 DIN7991</b>	2
S31413	<b>M5x45 DIN9 12</b>	4
S31359	<b>Retaining bolt</b>	1
S31942	<b>Light coiled spring pin 5x30 Connex</b>	4
301181	<b>M8x30 DIN9 12</b>	4
624384	<b>M4 DIN934</b>	2
<b>optional</b>	<b>300 438 001 NT valve unit</b>	

### 10.3 930 134 001 – Spring loaded roller bar (UB160 PB160-400)

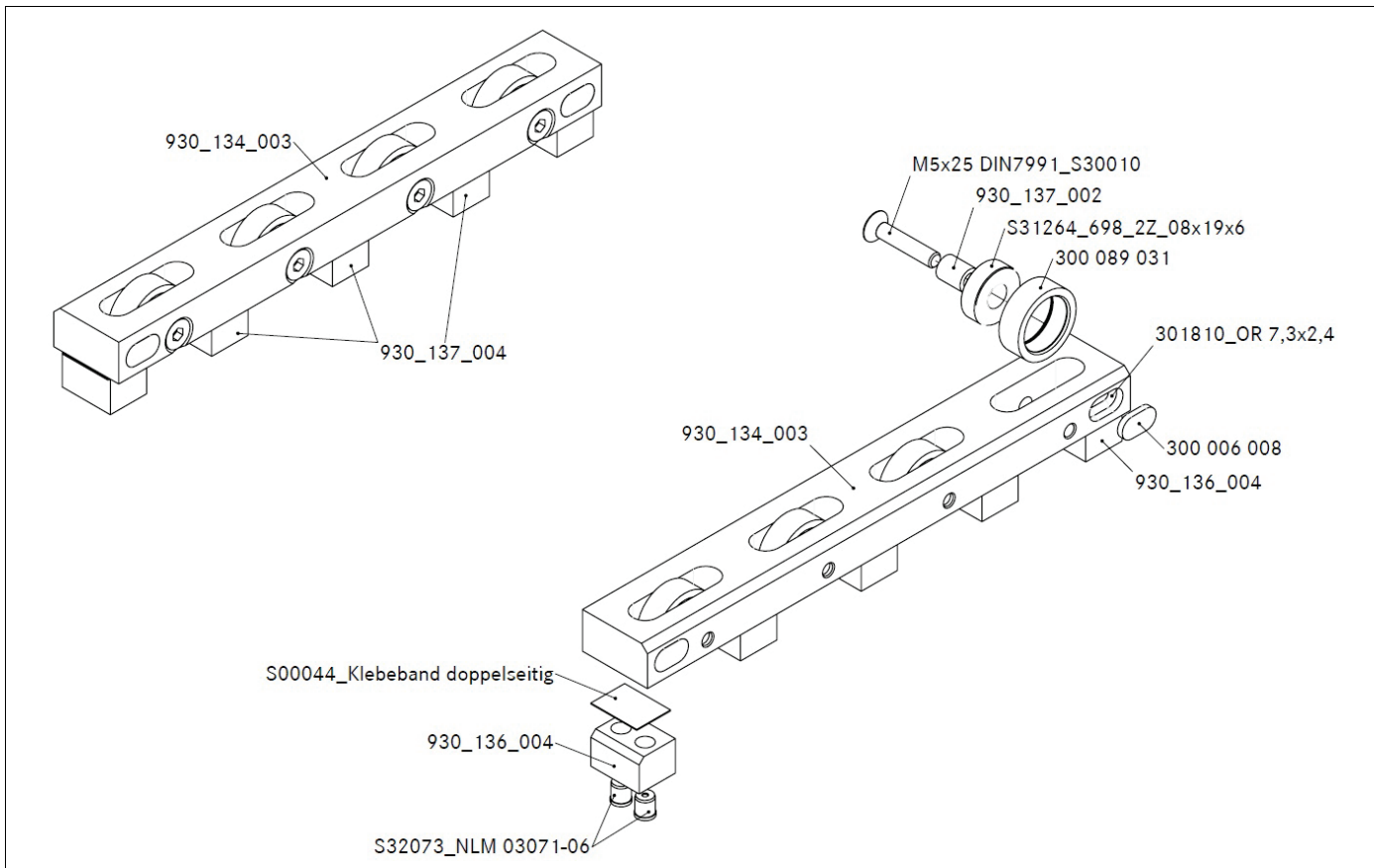

Fig. 10-3: Spring loaded roller bar for ZE/ZED in roller section (UB160 PB160-400)

**i**

Number of thrust pieces rounded up = (WT total weight (kg) : 0,9kg) + 2  
Spread evenly over the strips..

Order number	Description	Number
930_134_003	<b>Ledge</b>	2
300 006 008	<b>Sliding block</b>	8
300 089 031	<b>Bearing ring</b>	8
930_136_004	<b>Mounting for spring-loaded thrust pieces</b>	4
930_137_002	<b>Socket</b>	8
930_137_004	<b>Mounting for spring-loaded thrust pieces</b>	6
S31264	<b>Grooved ball bearing 698 2Z 8x19x6</b>	8
S30010	<b>M5x25 DIN7991</b>	8
S32073	<b>Sprung thrust piece</b>	20
S00044	<b>Double-sided adhesive tape H=0,35mm B=19mm L=50m</b>	10
301810	<b>O-Ring 7,3x2,4</b>	8



## 10.4 930 135 001 – Spring loaded roller bar (UB240 PB160-400)

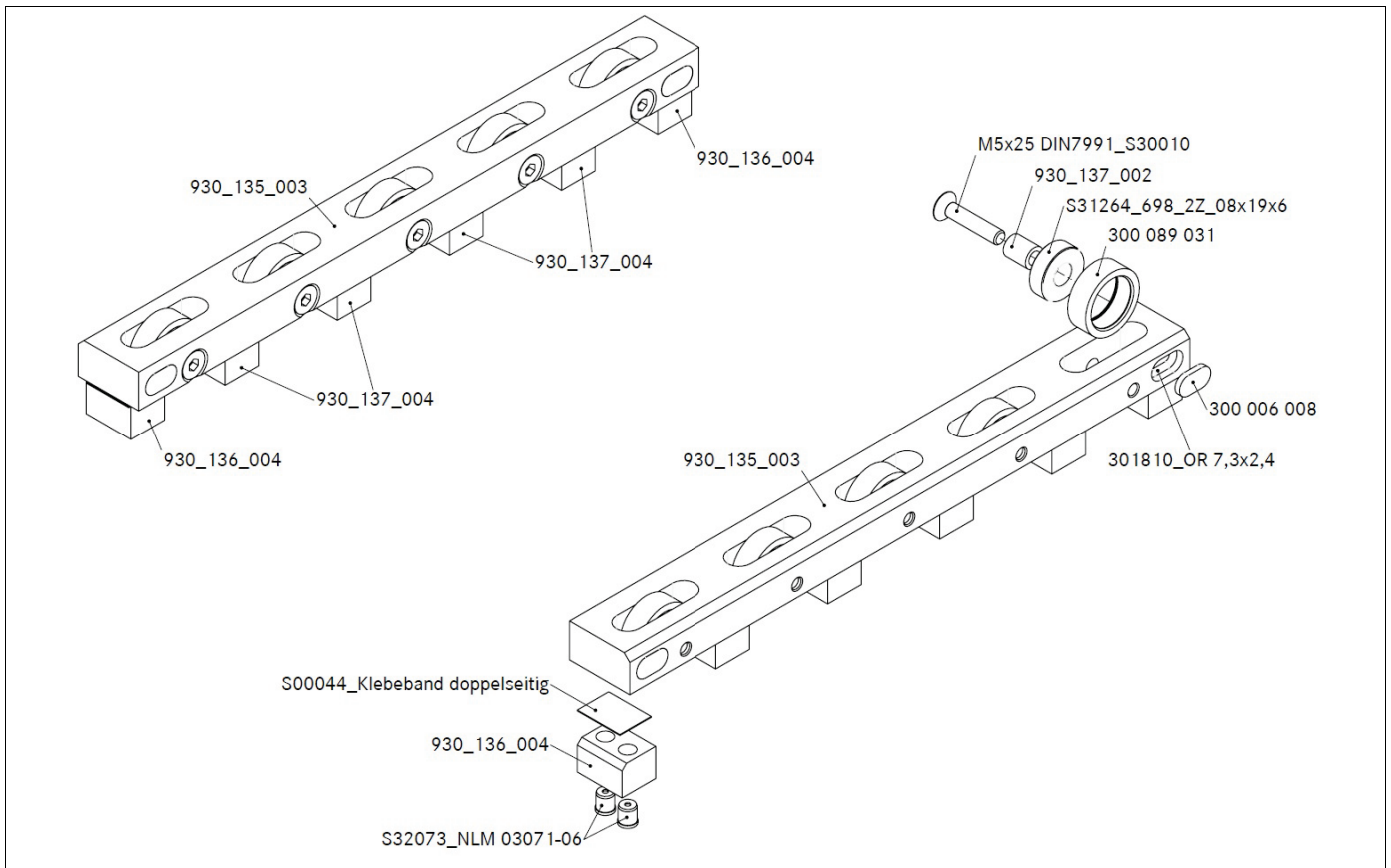

Fig. 10-4: Spring loaded roller bar for ZE/ZED in roller section (UB240 PB160-400)

**i**

Number of thrust pieces rounded up = (WT total weight (kg) : 0,9kg) + 2  
Spread evenly over the strips..

Order number	Description	Number
930_135_003	<b>Ledge</b>	2
300 006 008	<b>Sliding block</b>	8
300 089 031	<b>Bearing ring</b>	10
930_136_004	<b>Mounting for spring-loaded thrust pieces</b>	4
930_137_002	<b>Socket</b>	10
930_137_004	<b>Mounting for spring-loaded thrust pieces</b>	8
S31264	<b>Grooved ball bearing 698 2Z 8x19x6</b>	10
S30010	<b>M5x25 DIN7991</b>	10
S32073	<b>Sprung thrust piece</b>	24
S00044	<b>Double-sided adhesive tape H=0,35mm B=19mm L=50m</b>	12
301810	<b>O-Ring 7,3x2,4</b>	8

## 10.5 930 136 001 – Spring loaded roller bar (UB320 PB160-400)

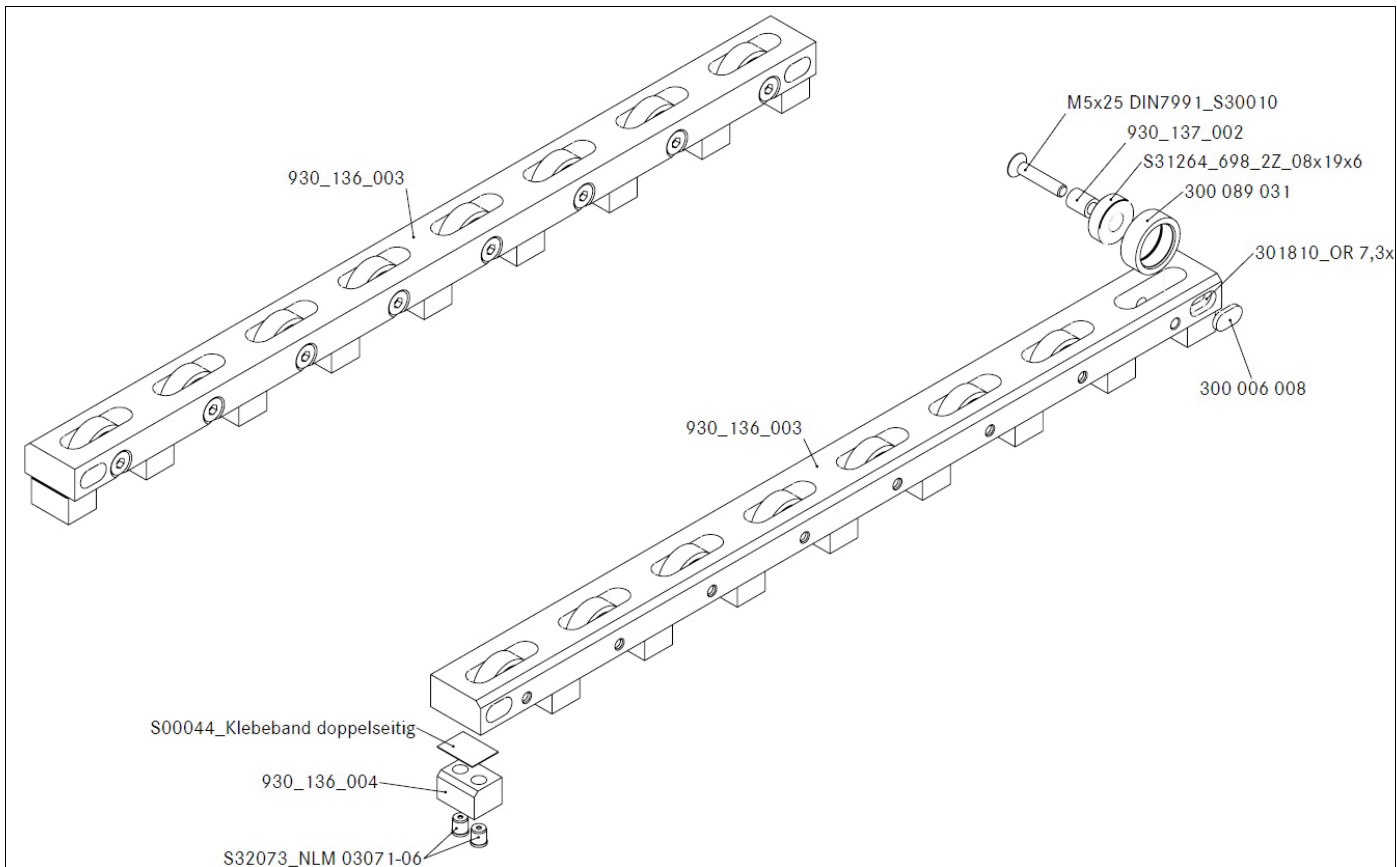

Fig. 10-5: Spring loaded roller bar for ZE/ZED in roller section (UB320 PB160-400)

**i**

Number of thrust pieces rounded up = (WT total weight (kg) : 0,9kg) + 2  
Spread evenly over the strips..

Order number	Description	Number
930_136_003	<b>Ledge</b>	2
300 006 008	<b>Sliding block</b>	8
300 089 031	<b>Bearing ring</b>	16
930_136_004	<b>Mounting for spring-loaded thrust pieces</b>	4
930_137_002	<b>Socket</b>	16
930_137_004	<b>Mounting for spring-loaded thrust pieces</b>	12
S31264	<b>Grooved ball bearing 698 2Z 8x19x6</b>	16
S30010	<b>M5x25 DIN7991</b>	16
S32073	<b>Sprung thrust piece</b>	36
S00044	<b>Double-sided adhesive tape H=0,35mm B=19mm L=50m</b>	18
301810	<b>O-Ring 7,3x2,4</b>	8

## 10.6 930 137 001 – Spring loaded roller bar (UB400 PB160-400)

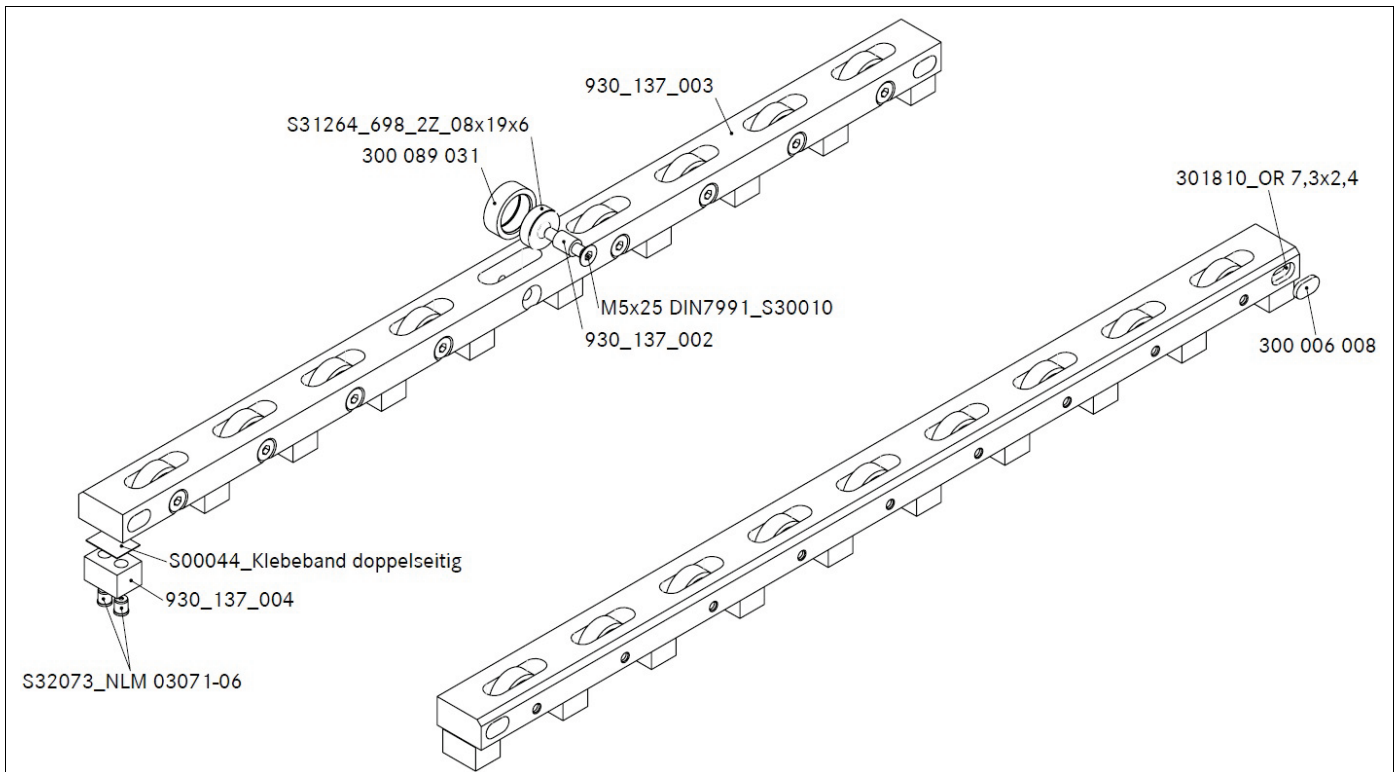

Fig. 10-6: Spring loaded roller bar for ZE/ZED in roller section (UB400 PB160-400)

**i**

Number of thrust pieces rounded up = (WT total weight (kg) : 0,9kg) + 2  
Spread evenly over the strips..

Order number	Description	Number
930_137_002	<b>Socket</b>	18
930_137_003	<b>Ledge</b>	2
930_137_004	<b>Mounting for spring-loaded thrust pieces</b>	20
300 089 031	<b>Bearing ring</b>	18
300 006 008	<b>Sliding block</b>	4
S31264	<b>Grooved ball bearing 698 2Z 8x19x6</b>	18
S30010	<b>M5x25 DIN7991</b>	18
S32073	<b>Sprung thrust piece</b>	40
S00044	<b>Double-sided adhesive tape H=0,35mm B=19mm L=50m</b>	20
301810	<b>O-Ring 7,3x2,4</b>	8

## 11 Appendix

### 11.1 Technical data

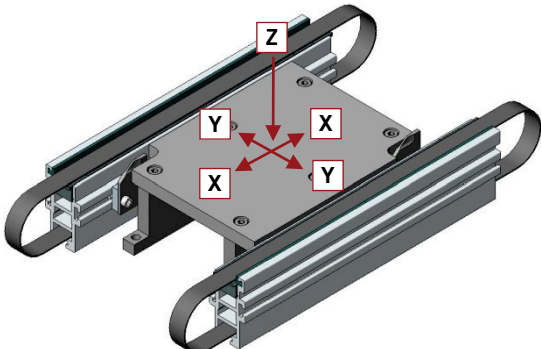
Centring device ZE	
<b>Sizes available</b>	160 x 160 mm – 400 x 400 mm, variable (square, also not quadratic measurements)
<b>Weight</b>	approx. 15 kg (depends on the size)
<b>Permissible workpiece carrier loading</b>	 <ul style="list-style-type: none"> <li>• X-axis none</li> <li>• Y-axis 50 N</li> <li>• Z-axis 30 kN</li> </ul>
<b>Maximum centring accuracy</b>	<ul style="list-style-type: none"> <li>• X axis +/- 0.22 mm</li> <li>• Y axis +/- 0.15 mm</li> <li>• Y axis up to + 0.5 mm</li> </ul>
<b>Spring force</b>	<ul style="list-style-type: none"> <li>• approx. 9N per thrust piece – starting pressure = 6N, for a stroke of 0.8 mm</li> </ul>

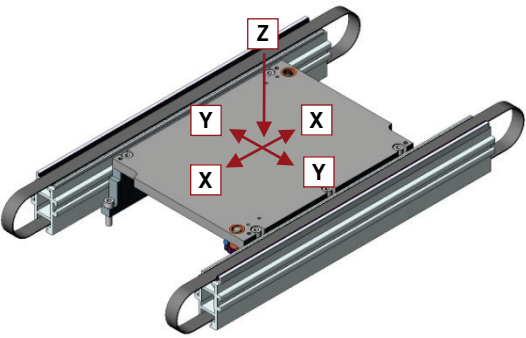
<b>Centring device ZED</b>	
<b>Sizes available</b>	160 x 160 mm – 400 x 400 mm, variable (square, also not quadratic measurements)
<b>Weight</b>	approx. 15 kg (depends on the size)
<b>Permissible workpiece carrier loading</b>	 <ul style="list-style-type: none"> <li>• X-axis 200 N</li> <li>• X-axis 200 N</li> <li>• Z-axis 30 kN</li> </ul>
<b>Maximum centring accuracy</b>	<ul style="list-style-type: none"> <li>• X axis +/- 0.02 mm</li> <li>• Y axis +/- 0.02 mm</li> <li>• Y axis up to + 0.5 mm</li> </ul>
<b>ZED - compressed air connection</b>	G 1/8" max. 4 bar
<b>Sound power level (Distance to the sound source 1 m)</b>	< 65 db (A)
<b>Spring force of the thrust pieces</b>	<ul style="list-style-type: none"> <li>• approx. 9N per thrust piece – starting pressure = 6N, for a stroke of 0.8 mm</li> </ul>



The pin assignment plan of the drive motor can be found in the operating manual “Belt element”.

This information reflects the technical status at the time of printing.  
STEIN Automation reserves the right to make technical alterations.

## **STEIN Automation GmbH & Co. KG**

Carl-Haag-Straße 26  
78054 VS-Schwenningen

Telephone +49 (0)7720 / 8307-0  
info@stein-automation.de

**[www.stein-automation.de](http://www.stein-automation.de)**