

Stop Devices (SE) / P-Positions SOFTMOVE

STEIN Workpiece Transport System (STEIN 300 SoftMove)

Operating instructions

Attention all installation, operating and maintenance personnel -
always keep these instructions with the stop device!

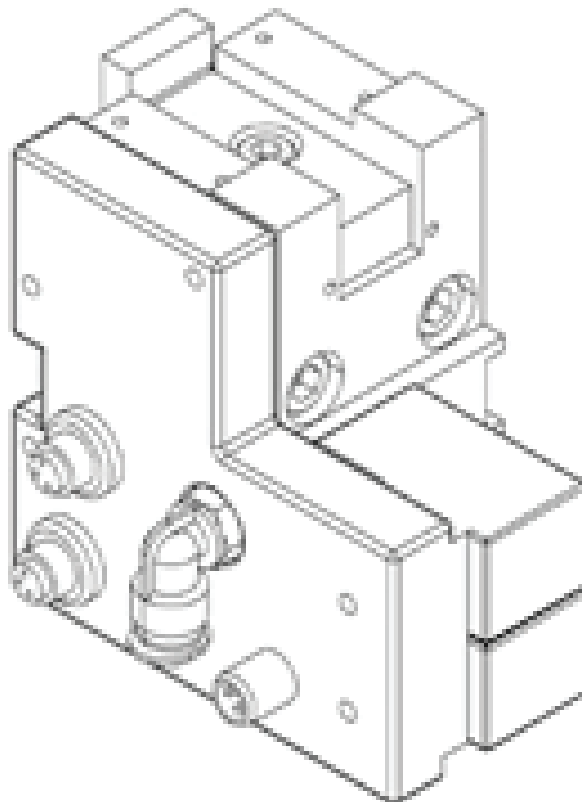

© STEIN Automation

The copyright in these documents is reserved by STEIN Automation.

Original language of the documentation: German

These documents may not be altered, distributed, reproduced or transferred to third parties without the prior written permission of STEIN Automation.

STEIN Automation GmbH & Co. KG

Carl-Haag-Straße 26
78054 VS-Schwenningen, Germany

Telephone: (+)49 (0)7720 / 8307 - 0

Publication date: October 2018

The right to make changes in design and construction is reserved.

Table of contents

1	Abbreviations and symbols	5
1.1	Explanation of safety and warning notices	5
2	Introduction	6
2.1	Short description.....	7
2.2	Initial inspection.....	8
2.3	Complaints.....	8
2.4	Warranty	8
3	Safety information	9
3.1	General safety information	9
3.2	Appropriate use and liability exclusions	9
3.3	Product misuse	10
3.4	Residual danger	11
4	Technical description	12
4.1	Contents	12
4.2	System components.....	12
5	Stop situations	14
5.1	Stop device for workstations	14
6	ASI stop device.....	15
6.1	Technical data - ASI stop device.....	16
7	Installing the stop devices.....	17
7.1	Procedure	17
7.2	Preparation	17
7.3	Installing the stop device.....	18
7.4	Installing the stop devices and centring rails	19
7.5	Connecting the stop device to the compressed air supply	20
7.6	Connecting the stop device to the electrical power supply (ASI Bus)	21
8	Accessories.....	22
8.1	ASI stop device overview.....	22
8.2	300 423 001 ASI stop device (ASI-S).....	23
8.3	300 424 001 ASI pre-stop device (ASI-VS) left	24
8.4	930 104 001 ASI pre-stop device (ASI-VS) right	25
8.5	300 425 001 ASI workstation stop device (ASI-AS)	26
8.6	300 642 001 ASI workstation pre-stop device SoftMove (VSSM).....	27
8.7	300 426 001 ASI workstation stop device left (ASI-AS-L)	28
8.8	300 427 001 ASI supply side stop device (ASI-ES)	29
8.9	300 428 001 ASI workstation stop device with offset stop (ASI-ASA)	30
8.10	300 429 001 ASI workstation stop device with offset stop (ASI-ASB)	31
8.11	300 429 001 ASI workstation stop device with offset stop (ASI-ASC)	32
8.12	Components of the accessory items.....	33
9	P-Positions Soft Move.....	41
9.1	P1S / P3S (Corner 90° BE→QE)	41
9.2	P2S / P4S (Corner 90° QE→BE)	42
9.3	P5S / P7S (A-workstation entry)	43
9.4	P6S / P8S (A-workstation exit).....	44

9.5	P9S / P10S (Corner 180°)	45
9.6	P11S / P12S (B-workstation entry)	46
9.7	P13S / P15S (C-workstation entry)	47
9.8	P14S / P16S (C-workstation exit)	48
9.9	P21S / P23S (A-workstation corner entry)	49
9.10	P22S / P24S (A-workstation corner exit)	50
9.11	P25S / P27S (B-workstation corner entry)	51
9.12	P26S / P28S (B-workstation corner exit)	52
9.13	P29S / P31S (C-workstation corner entry)	53
9.14	P30S / P32S (C-workstation corner exit)	54
10	P-Positions Soft Move 4G	55
10.1	P5S 4G / P7S 4G (A-workstation entry)	55
10.2	P11S 4G / P12S 4G (B-workstation entry)	56
10.3	P13S 4G / P15S 4G (C-workstation entry)	57
10.4	P21S 4G / P23S 4G (A-workstation corner entry)	58
10.5	P25S 4G / P27S 4G (B-workstation corner entry)	59
10.6	P26S 4G / P28S 4G (B-workstation corner exit)	60
10.7	P29S 4G / P31S 4G (C-workstation corner entry)	61
11	Initial operation	62
12	Faults	62
13	Cleaning and maintenance	63
13.1	Cleaning	63
13.2	Maintenance	64
14	Appendix	64
14.1	Technical data	64

1 Abbreviations and symbols

- Action symbol
- 1 Symbol for actions that must be carried out in a specified sequence.
- ⇒ Consequence or result of an action
- Count
- SE Stop devices
- WT Pallets
- BE Belt element
- BA Operating instructions
- Fig. Figure



This sign indicates information that will allow the stop device to be used more effectively and more economically.

The symbols used in the operating instructions for safety and hazard warnings are described in detail in Chapter 3.

1.1 Explanation of safety and warning notices

The following safety signs explain all the situations or actions where danger to life and limb for machine operators or their colleagues exists.

Strictly comply with these instructions and act with particular care in these cases. Pass all safety notices on to all other users.



DANGER!

The symbol with the added designation DANGER describes a directly impending hazards!

The hazard results in serious injury to people or even fatalities.



WARNING!

The symbol with the added designation WARNING describes a potentially impending hazards!

The hazard may result in serious injury to people or even fatalities.



CAUTION!

The symbol with the added designation CAUTION describes a potentially hazardous situation!

The hazard can result in injury to people.

The safety signs appear frequently in the text with a picture to explain what the source of the hazard is.



CRUSHING HAZARD!

This symbol gives warning of a location where there is a risk of being crushed.



HIGH ELECTRICAL VOLTAGE!

This symbol gives warning of possible electric shock.

It appears for all working and operating procedures that must be followed precisely, in order to avoid injury to personnel or damage to the system through high electrical voltage.

Other warning signs:



ATTENTION!

This symbol indicates warnings which, if ignored, will cause a hazard to the machine.



Protective clothing must be worn!

Wear your personal safety clothing:
Safety footwear, hard hat, goggles and safety gloves.



Environmental protection!

This sign indicates warnings that will help to avoid harming the environment.

2 Introduction

The safety of all persons who come into contact with the stop devices depends fundamentally on knowing how the stop devices function. Therefore:

Read these operating instructions before using the devices for the first time.

These operating instructions contain important information which will ensure the correct, economical and safe operation of your stop devices.

2.1 Short description

The stop devices by STEIN Automation are optional accessories for the STEIN 300 SOFTMOVE Workpiece Transport System.

Together with the STEIN 300, these devices enable the stopping, separation and positioning of the pallets and thus the workpieces found on the pallets.

Fig. 2-1:
Stop device

- 1 Belt element
- 2 Pallet
- 3 Stop device

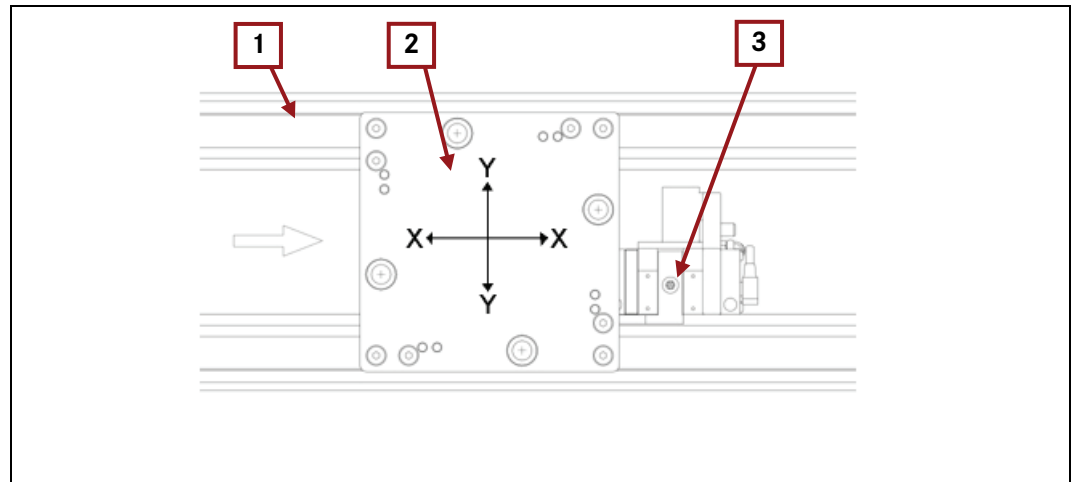

The simplest type of these devices is a stop device, which stops the pallet (WT) in a defined position at a workstation.

Fig. 2-2:
Stop devices and centring rails

- 1 Belt element
- 2 Pallet
- 3 Stop device
- 4 Centring rails

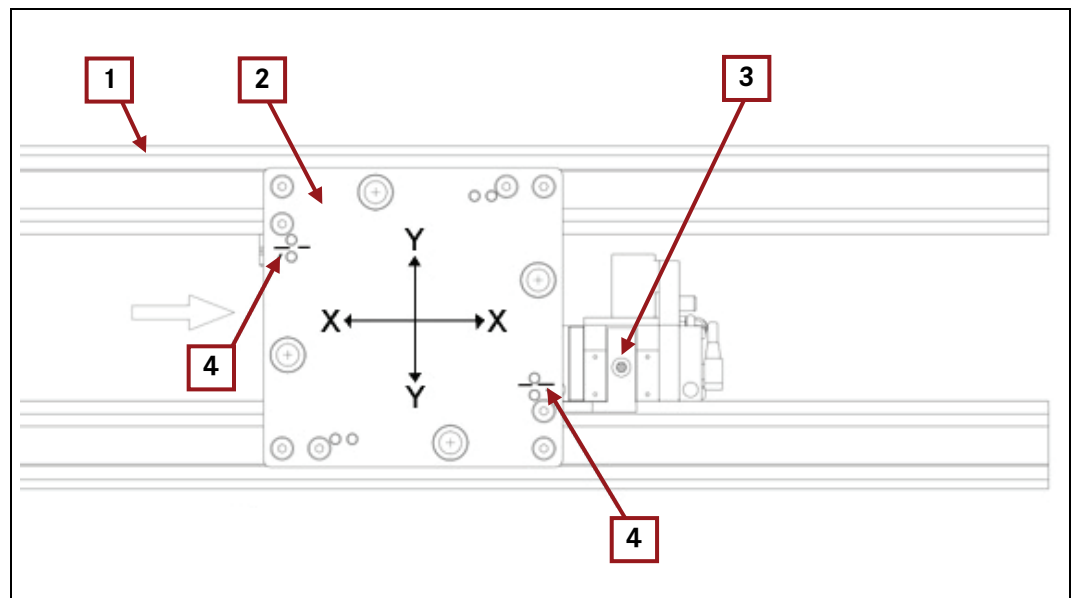

For workstations, which require a more exact positioning of the pallet in the X and Y axis, the use of a stop device with two centring rails will serve the purpose. The centring rails are screwed on internally on both sides on the belt profile.

2.2 Initial inspection

- Unpack all the components supplied.



Environmental protection.

Dispose of all packaging material in an environmentally responsible way.

Then carry out an initial inspection.

Check that:

- all components detailed on the delivery note have been supplied
- components have not been damaged or lost in transit.

2.3 Complaints

In order for claims for damage caused in transit to be accepted, follow this procedure:

- Inform the freight company.
- Draw up a damage report giving the following details
 - Name and address of recipient
 - Item or order number
 - A description of the damage.
- Send components, if possible in their original packaging, with the damage report, back to the manufacturer.

2.4 Warranty

For the stop device and its spare parts we grant the legal guarantee period or rather the defined guarantee period in the contract, starting with the day of delivery.

During this warranty period we will replace any components defective in manufacture or materials free of charge.

STEIN Automation's general warranty conditions also apply.

3 Safety information

3.1 General safety information

- The stop devices from STEIN Automation are high-quality products, manufactured to recognised technical rules.
The stop devices left the manufacturer's factory in good condition from a safety and technical point of view.
- All versions of the stop devices comply with the requirements of UVV, the German accident prevention regulations.
- To maintain this situation, installation staff, users and service technicians must observe the notices and warnings contained in these operating instructions.
- Stop devices must only be installed and repaired by authorised personnel who have been trained by STEIN Automation.
- Only genuine spare parts from STEIN Automation may be used when carrying out repairs to the stop devices.

3.2 Appropriate use and liability exclusions

The stop devices should only

- used in STEIN 300 belt systems,
- be operated together with suitable pallets with permitted dimensions and weights,
- only be used for the purpose relevant to the model,
- be operated indoors,
- be operated in dry areas,
- be used in areas where there is no risk of explosion.
- be operated in an environment that is free of oil and shavings.

Centring precision and stresses on the system can be found in the Chapter 14.1 Technical data.

i

Unauthorised interventions, alterations or repairs carried out to the stop devices invalidate the warranty.

STEIN Automation shall not be liable for damages sustained due to unauthorised interventions, changes or repairs!

Fig. 3-1:
Maximum
loads for the stop de-
vices

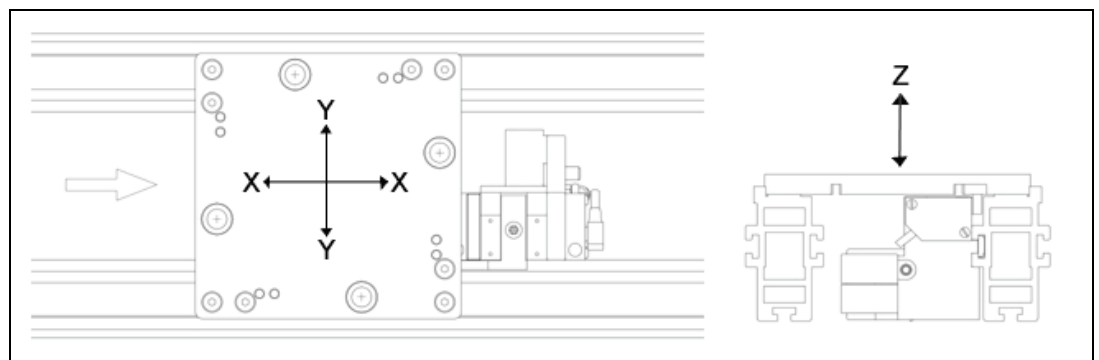

For the stop device, the permitted pallet load (pallet + workpiece - at medium load and STEIN operating pressure of 4 bar) is

- in the X axis: none
- in the Y axis: 100 N
- in the Z axis: 50 N

Fig. 3-2:
Maximum loads for
stop devices with cen-
tring rails(Pos 1)

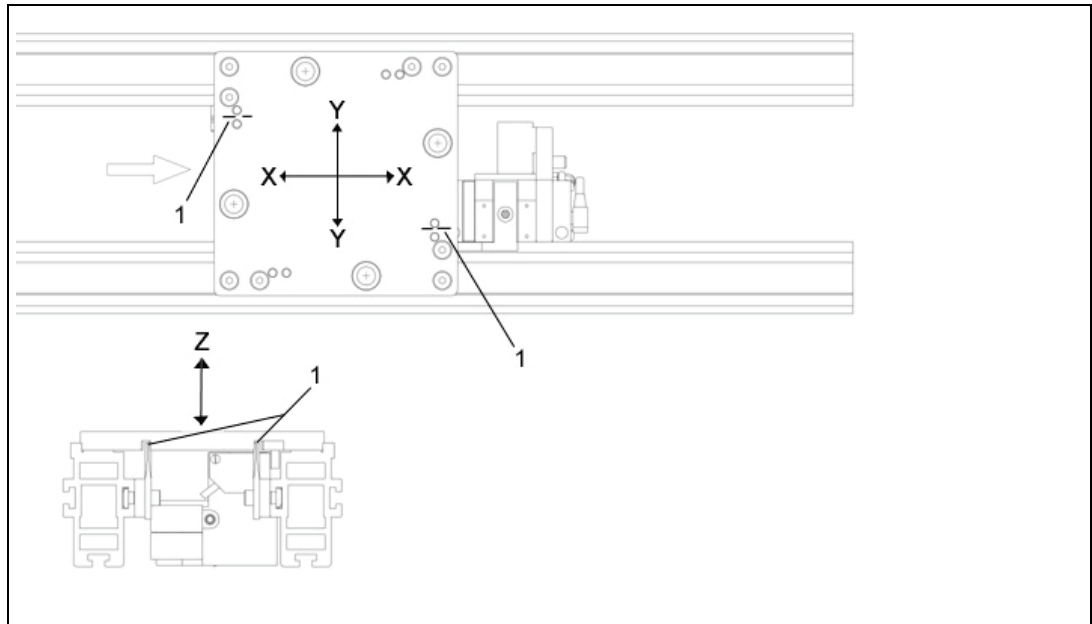

For stop devices with a centring rail, the permitted pallet load (pallet + workpiece - at medium load and STEIN operating pressure of 4 bar) is

- in the X axis: none
- in the Y axis: 100 N
- in the Z axis: 50 N

i

Unauthorised interventions, alterations or repairs carried out to the stop devices invalidate the warranty.

STEIN Automation shall not be liable for damages sustained due to unauthorised interventions, changes or repairs!

3.3 Product misuse

The stop devices may not be used

- in queue mode.

STEIN Automation shall not be liable for damages sustained due to unauthorised interventions, changes or repairs!

3.4 Residual danger

The stop devices are manufactured using state-of-the-art technology and to recognised safety standards. Nevertheless their use can lead to dangerous situations for users or third parties or to impairments of the system and other material assets.

During the transport of pallets and products, the following injuries can result:

- Crushing and collision:
 - from jamming between the pallet and the stop devices,
 - from moving the pneumatic cylinders,
 - from parts protruding over the pallets.
- Injuries due to the condition of the product being transported.

Fig. 3-3:
Possible places for
- jamming

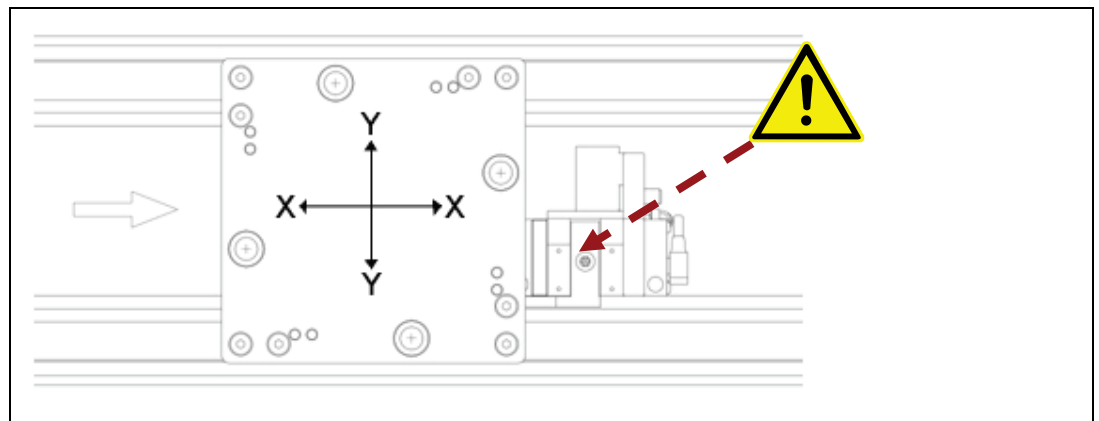

Mechanical protection.



WARNING!

The stop devices are supplied without protective covers. These must be adapted by the customer to the specific requirements and installed.



WARNING!

Operating the facility without correct and fully mounted protective covers is not permitted.

4 Technical description

4.1 Contents

The stop devices must be installed by the customer or are delivered fully installed and ready to connect.



WARNING!

The stop devices are supplied without protective covers. These must be adapted by the customer to the specific requirements and installed.



WARNING

The scope of delivery for the stop devices does not include a controller! This must be ordered separately.

The stop devices are fitted with ASI electronics and controlled via the ASI bus.

4.2 System components

Fig. 4-1:
Stop devices

- 1 Belt element
- 2 Pallet
- 3 Stop device

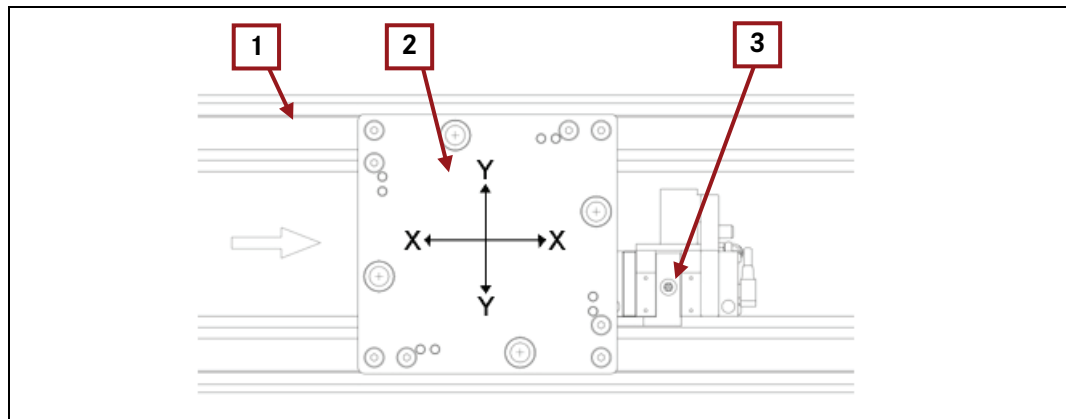

The simplest type of these devices is a stop device, which stops the pallet (WT) in a defined position at a workstation.

Application:

At manual workstations, e.g. to place or install parts.

Pallet position:

Pallet precision in the belt system +/- 1 mm in the Y axis.

By stopping off-centre the pallet can skew the pallet.

The position of the pallet can change by 0.5 mm in the Z axis.



The pallet can be moved against the direction travel from the stop device (X axis).

Fig. 4-2:
Stop devices and
centring rails

- 1 Belt element
- 2 Pallet
- 3 Stop device
- 4 Centring rails

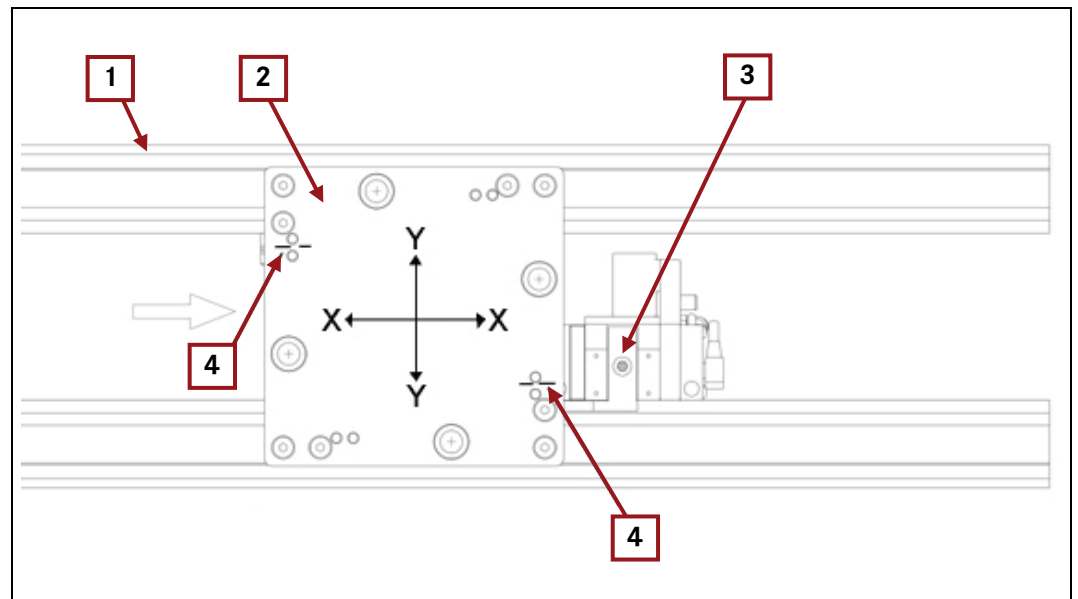

For workstations, which require a more exact positioning of the pallet in the X and Y axis, the use of a stop device with two centring rails will serve the purpose. The centring rails are screwed on internally on both sides on the belt profile.

Function:

To stop the pallet with centring in the centring rail.

Application:

For manual and automatic workstations where a more precise position of the pallet is required.

Pallet position:

Pallet precision in the X axis +/- 0.25 mm and Y axis +/- 0.15 mm.
The position of the pallet can change by up to 0.5 mm in the Z axis.

i

The pallet can be moved against the direction of travel from the stop device (X axis).

5 Stop situations

The installing sets shown under the heading "Stop situations" facilitate the pallet's stopping at a manual or automatic workstation in order to, for instance, carry out configurations or installation work on the workpiece.

The sets are always composed of various accessory parts depending on customer-specific control elements (e.g. electric or pneumatic foot switches to stop or release the pallets).

The following diagrams show the maximum configuration of the stop situation.

Please the documents specific to the order for the actual configuration.

5.1 Stop device for workstations

Design of a standard stop situation (stop position).

Fig. 5-1:
Stop position

- 1 Workstation stop device
- 2 Workstation (ws) pre-stop device
- 3 Read head
- 4 Surface switch (optional)
- 5 Centring rails
- 6 Pallet on the ws stop device
- 7 Pallet on the ws pre-stop device
- 8 Free space behind the processing position

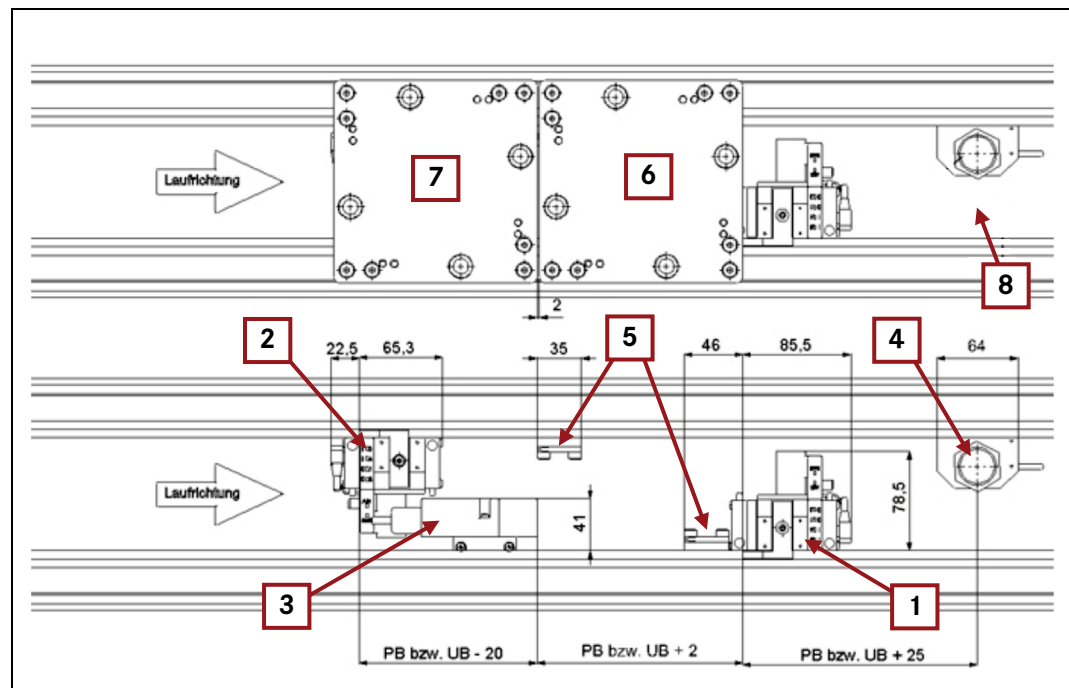

WARNING

To permit the reliable functioning of the logistics, it is essential to maintain the prescribed allocation of read head and stop position.

The read head must be positioned so that only the pallet which is in the processing position at the workstation stop device is read. The code carrier from the subsequent pallets must only pass over the read head once it enters the processing position.

6 ASI stop device

Fig. 6-1:
ASI stop device

- 1** Pneumatic stop device
- 2** ASI electronics
- 3** Intermediate plate
- 4** Proximity switch
- 5** Pn valve
- 6** Air connection
- 7** Connection to the ASI cable
- 8** Plug for the proximity switch
- 9** Status LED red
- 10** Status LED red
- 11** I.3 Status LED green
- 12** I.4 Status LED green
- 13** O.1 Status LED yellow
- 14** O.2 Status LED yellow

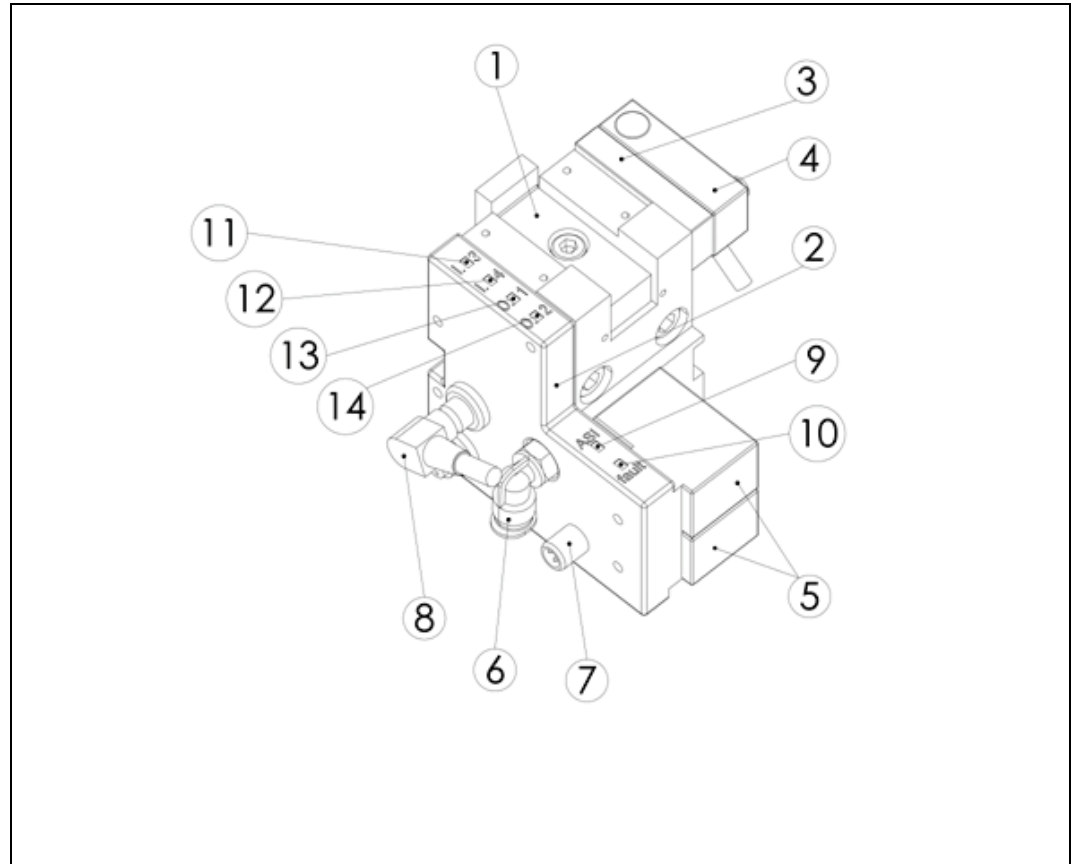

Diagnosis of the status display

ASI (green)	fault (red)	
on	off	AS interface power available - no fault
off	off	No AS interface power at the bus
flashes	on	AS interface addresses not set (equals null)
on	flashes	Short / input overload

I.3 (green) and I.4 (green)	Signal at the sensor inputs (optional 1 or 2 switches)
O.1 (yellow)	Valve coil 1 activated, move cylinders in
O.2 (yellow)	Valve coil 2 activated, move cylinders out

Status LED (green/yellow)	
on	1 signal at OUTPUT/Input
off	0 signal at OUTPUT/Input



The ASI stop devices (stop devices) are available in several designs, whereby the actual functional principle is always the same.

The various designs only differ in their design (offset) of the stopper latch and the configuration of the proximity switch.

6.1 Technical data - ASI stop device

Fig. 6-2:
Pneumatic plan

- 1 Pneumatic stop device (stopper latch up/down)
- 2 Pneumatic valves

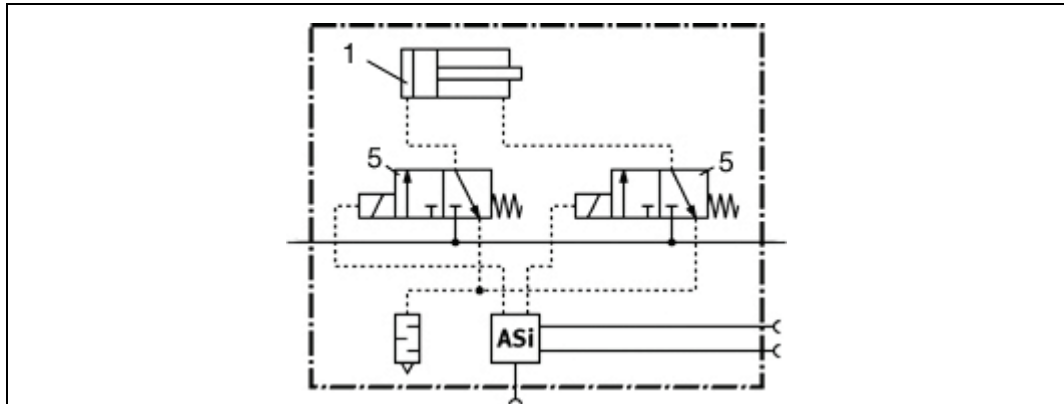

Electric data

Permitted address range	00 ... 31 (factory setting 00)
Supply	26.5 ... 31.6 VDC
Residual ripple	≤ 20 mVss
Standby current	max. 20 mA
Operating current	max. 250 mA (incl. power consumption of the sensors)
ASI profile	ID ₁ =F _H ID ₂ =E _H ID ₁ =F _H ID=B _H S-B, F, E
Watchdog	inactive
Data bit allocation	D0 actuator → 1 retract energized valve coil 0 valve coil is switched off D1 actuator → 1 extend energized valve coil 0 valve coil is switched off D2 actuator → 1 sensor 1 output signal 1 0 sensor 1 output signal 0 D3 actuator → 1 sensor 2 output signal 1 0 sensor 2 output signal 0

Connections

ASI	Plug max.1, PIN 1 ASI+, PIN 3 ASI-
Sensors	Sockets with snap collar M8 Pin assignment as per DIN-EN-60947-5-2 Positive switching PNP 24 VCD
Logic level	IN 11 V ... 30 V OUT 0 V ... 5 V

Pin assignment sensor connection

- 1. 24 V
- 3. 0 V
- 4. Input In-1

7 Installing the stop devices

The following installation description relates to the installation

- of the stop device and
- The stop device with centring rails.

The stop device and the centring rails are mounted directly inside on the belt profile of the belt element.

7.1 Procedure

The installation procedure can be divided into 5 phases:

- Preparation,
- Installing the stop device/centring rails/ and sensors,
- Connecting the stop device and sensors to the electrical power supply,
- Connecting the stop device to the compressed air supply,
- Fitting the safety equipment (covers).



Please observe the design and measurements of the standard stop situation (stop position) (see Chapter 5.1).



WARNING

On operating stations which generate shavings (for example drilling or thread-cutting machinery), covers should be installed to avoid shavings or cooling fluid coming into contact with the belt elements or the stop device.



Further information is available from STEIN Automation.

7.2 Preparation



DANGER!

From the Workpiece Transport System starting unexpectedly.



DANGER!

HIGH ELECTRICAL VOLTAGE

Electric shock hazard

- 1 Before carrying out any installation or repair work, disconnect the relevant Workpiece Transport System from its electrical power supply.
- 2 Disconnect the workpiece transport system from its compressed air supply
- 3 Put up warning signs to prevent the system being started up while installation and repair work is being done.
- 4 Remove the pallets from the relevant belt element.

7.3 Installing the stop device



Protective clothing must be worn

Wear your personal safety clothing: Safety footwear and safety gloves.

i

Installing the stop device does not require any changes to the belt elements!

i

Please observe the design and measurements of the standard stop situation (stop position) (see Chapter 5.1).

The stop devices are mounted on the inside of the belt elements on the guide profile. The position of the stop device in the X axis is pre-determined by the position of the workstation at the WTS.

Fig. 7-1:
Stop device

- 1 Stop device
- 2 Fixing screws

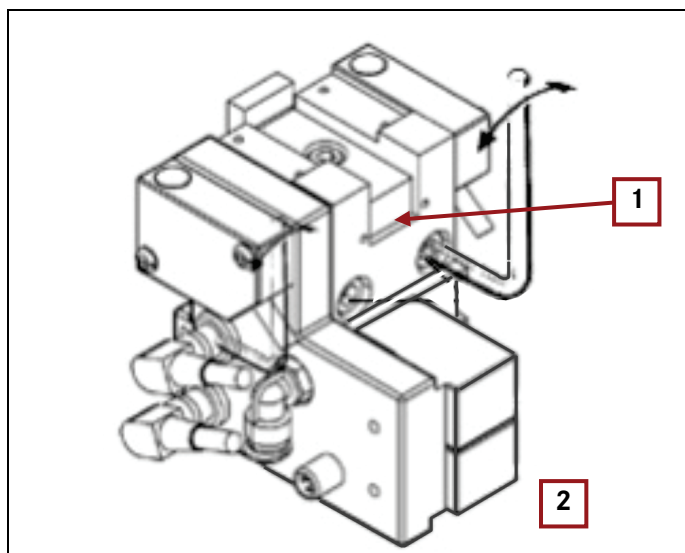

- To change the position of previously installed stop devices, unscrew the two fixing screws (2) with a wrench.
- Turn each of the screws one full turn counterclockwise with the wrench. This ensures the required twisting of the groove nuts when tightening the stop device.
- When the stop device is in the right position, tighten both screws (clockwise). In this process ensure that the groove nuts twist correctly.

i

Please refer to Chapter 8 and 9 for the installation dimensions and other dimensions of the stop devices.

7.4 Installing the stop devices and centring rails

The installation of the stop device for this model is the same as described under 7.3 Installing the stop device.

In addition, both centring rails must also be installed on the inside of the belt elements to the guide profile.



WARNING

The position of both centring rails depends on the position of the stop device and the dimensions of the pallet. Please see the representation in Chapter 5.1.

Fig. 7-2:
Centring rails

- 1 Centring rail
- 2 Fixing screws

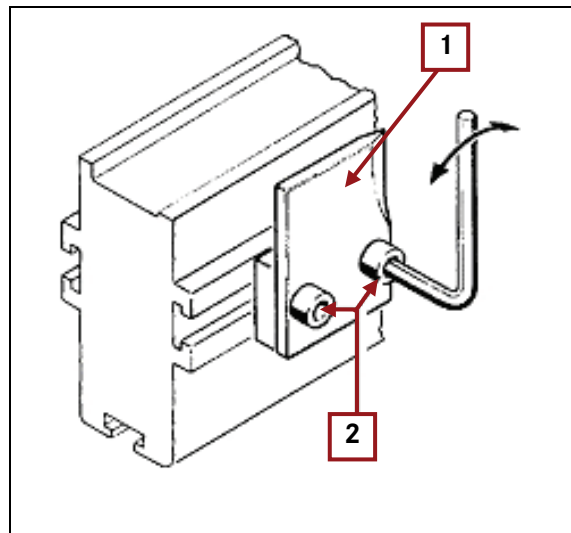

- ❑ To change the position of previously installed stop devices, unscrew the two fixing screws (2) with a wrench.
- ❑ Turn each of the screws one full turn counterclockwise with the wrench. This ensures the required twisting of the groove nuts when tightening the centring rail.
- ❑ When the centring rail is in the right position, tighten both screws (clockwise). In this process ensure that the groove nuts twist correctly.

7.5 Connecting the stop device to the compressed air supply



WARNING!

Only specialised personnel should connect the compressed air supply!



WARNING

Carry out installation work only in a pressureless state!



WARNING

Maximum operating pressure: 6 bar.
STEIN operating pressure: 4 bar.

i

Type PUN-S hoses with an exterior diameter of 6mm and wall thickness of 1mm are used, manufactured by: Festo.

Fig. 7-3:
Connecting the stop device to the compressed air supply

- 1 Compressed air supply connection
- 2 Pneumatic valves

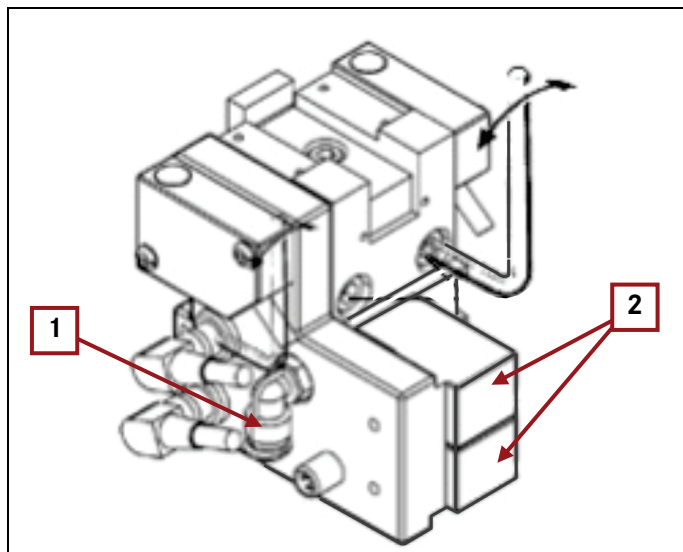

- Connect the stop device to the compressed air supply via the compressed air supply connection (1).

7.6 Connecting the stop device to the electrical power supply (ASI Bus)



Connection to the electrical power supply must be carried out exclusively by trained specialists from STEIN Automation!



Be sure to use only approved plug-and-socket systems when connecting to the power supply.

Fig. 7-4:

- 1 Anschluss ASI Kabel
- 2 ASI-Elektronik
- 3 Eingang I3 für Näherungsschalter
- 4 Eingang I4 für Näherungsschalter

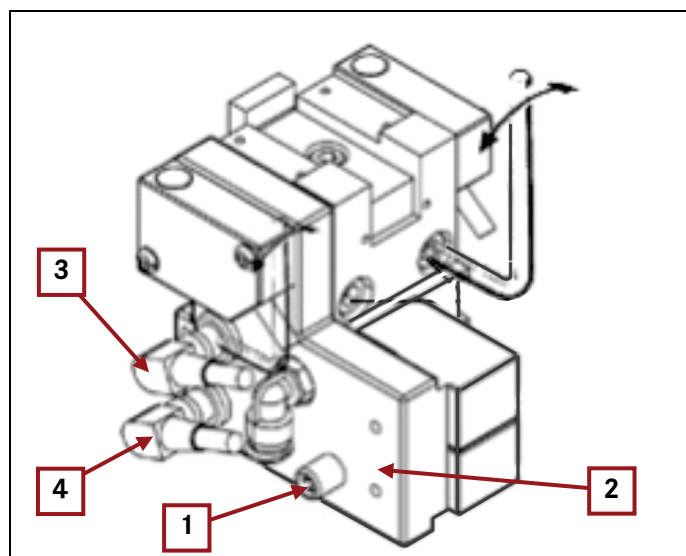

- Connect the stop devices to the ASI bus line via the ASI connection (1) with an ASI connecting cable.



Further information and important points can be found in the WTS 300 system documentation - Chapter "Replacing/addressing ASI components".

(When replacing/installing ASI components, please note that these may only be installed after they have been correctly addressed!)

8 Accessories

8.1 ASI stop device overview

300423001 ASI stop device (ASI-S)

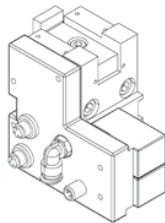

300 427 001 ASI supply side stop device (ASI-ES)

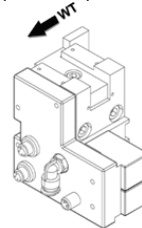

300426001 ASI workstation stop device left (ASI-AS-L)

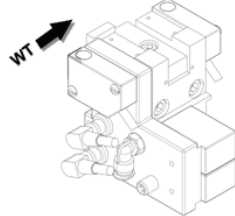

300425001 ASI workstation stop device (ASI-AS)

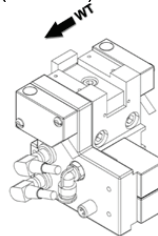

300424001 ASI pre-stop dev. (ASI-VS) left

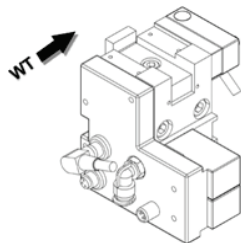

930104001 ASI pre-stop dev. (ASI-VS) right

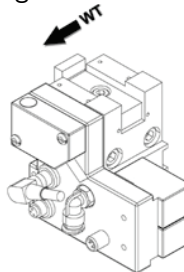

300428001 ASI workstation stop device with offset stop (ASI-ASA)

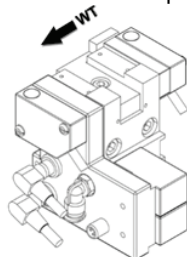

300429001 ASI workstation stop device with offset stop (ASI-ASB)

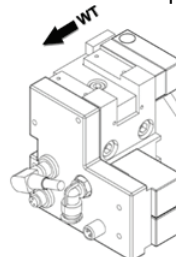

300430001 ASI workstation Stopp device with offset stop (ASI-ASC)

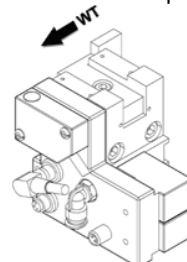

300642001 ASI pre-stop device SoftMove with offset stop (ASI-VSSM)

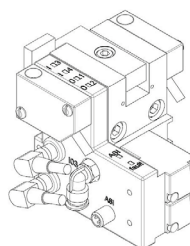

8.2 300 423 001 ASI stop device (ASI-S)

Fig. 8-1

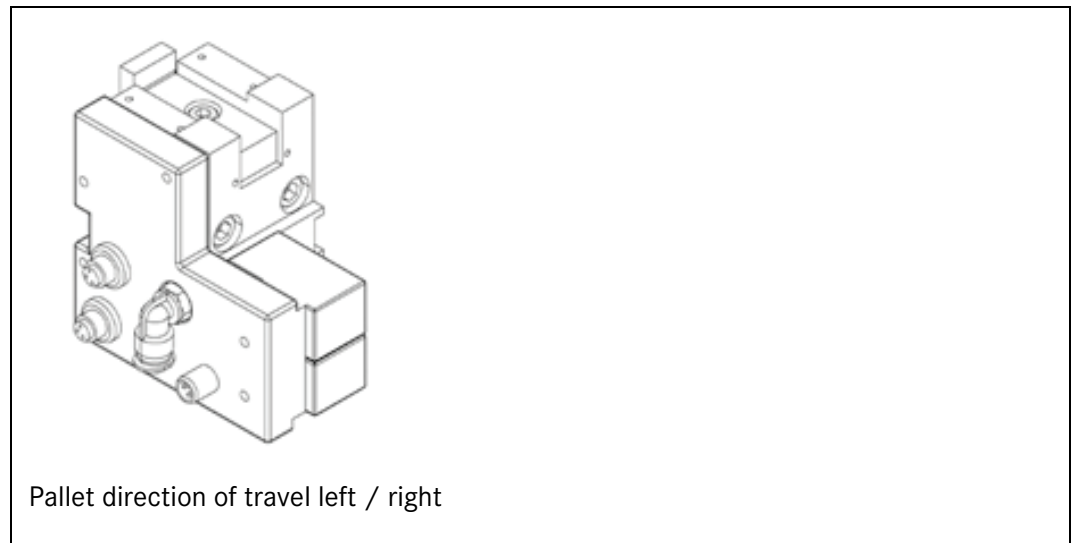
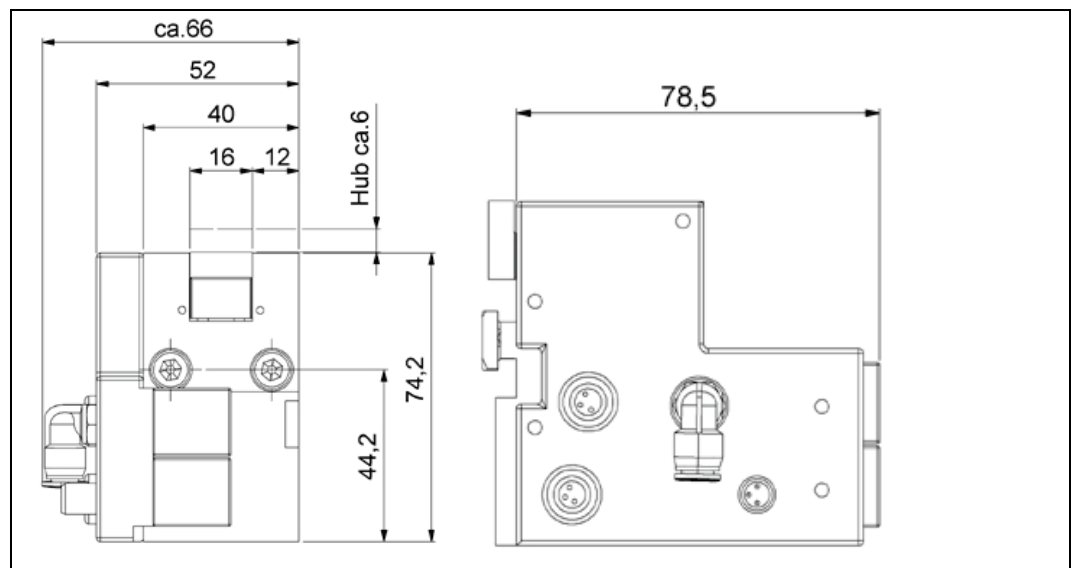

Fig. 8-2



8.3 300 424 001 ASI pre-stop device (ASI-VS) left

Fig. 8-3

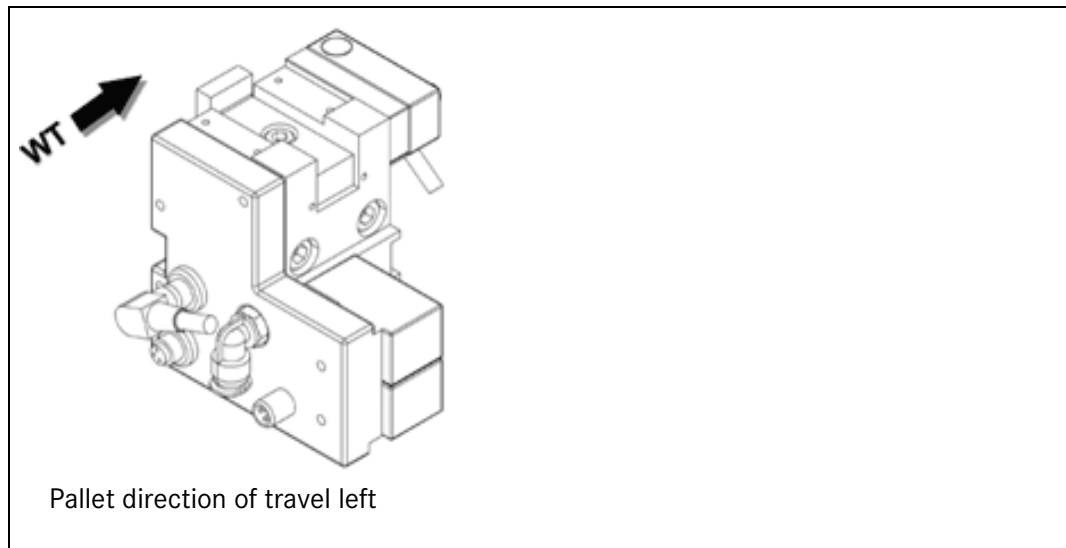
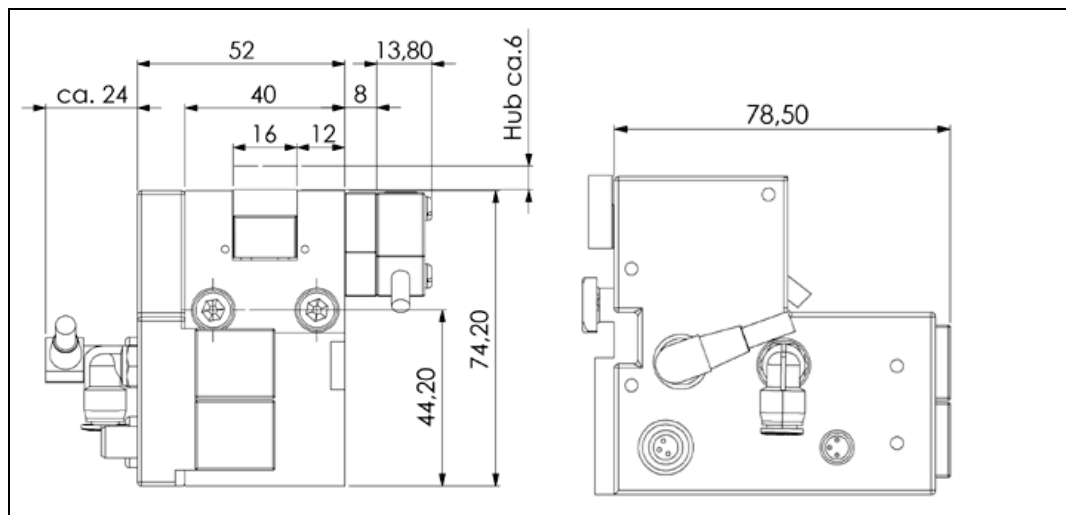

Fig. 8-4



8.4 930 104 001 ASI pre-stop device (ASI-VS) right

Fig. 8-5

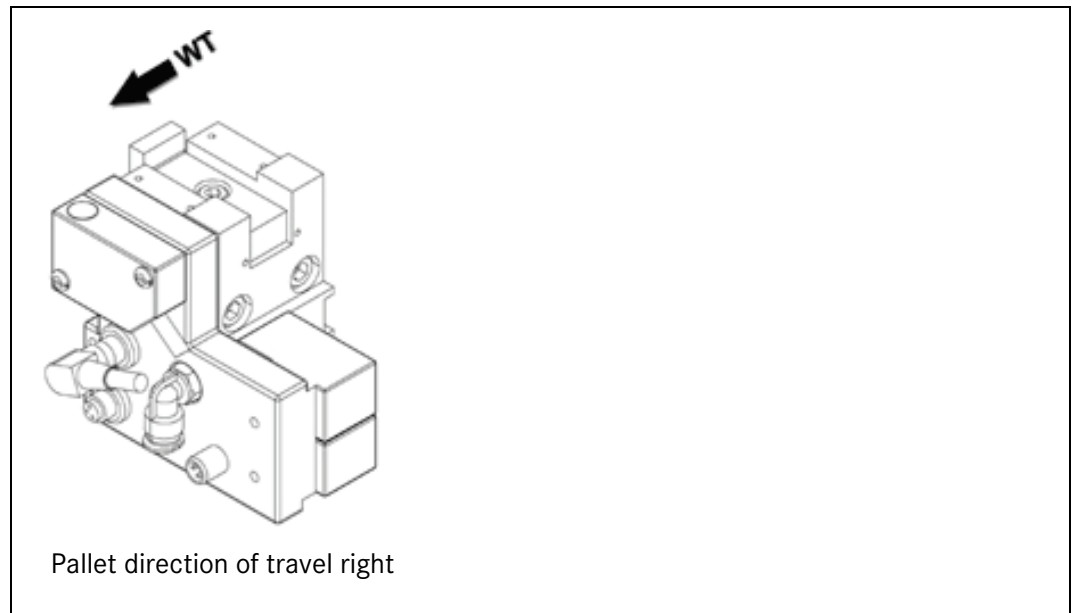
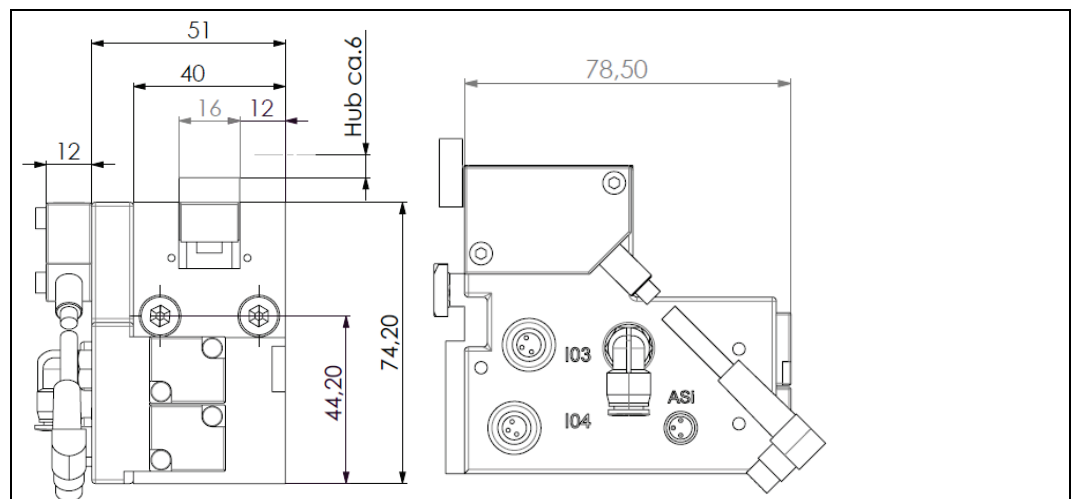

Fig. 8-6



8.5 300 425 001 ASI workstation stop device (ASI-AS)

Fig. 8-7

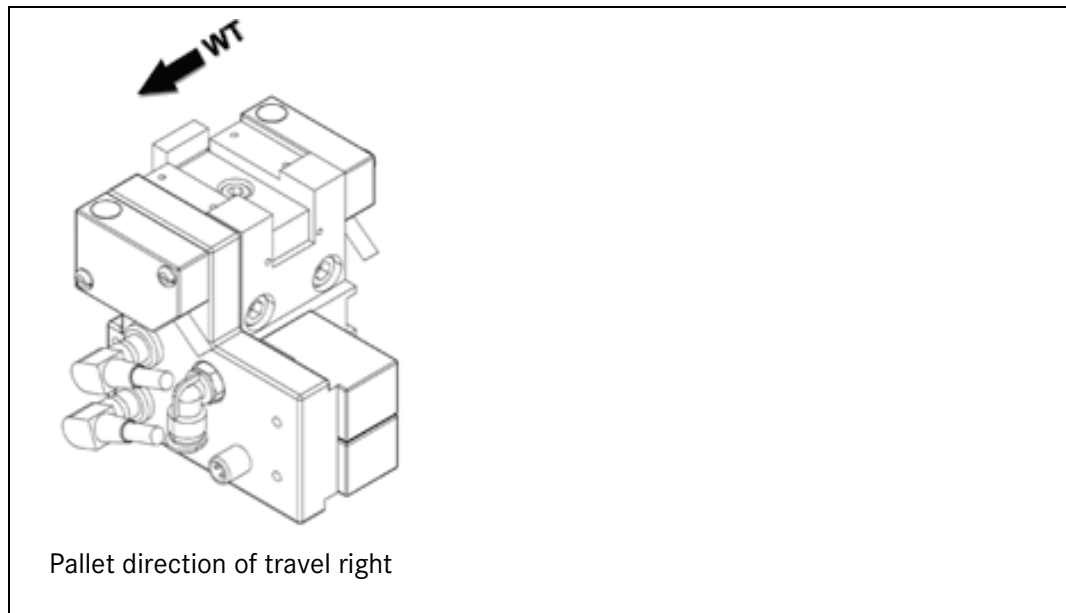
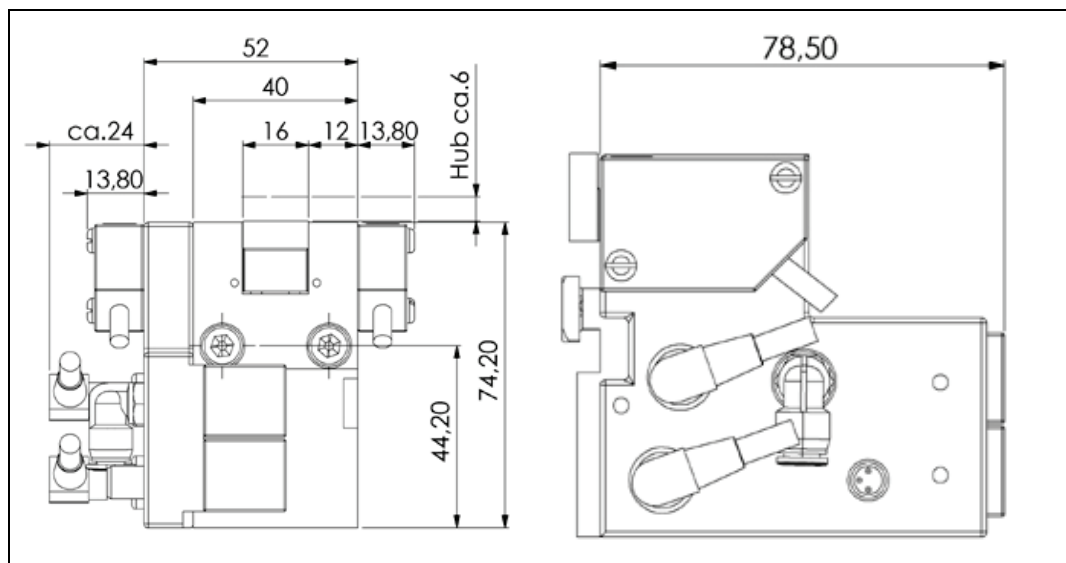

Fig. 8-8



8.6 300 642 001 ASI workstation pre-stop device SoftMove (VSSM)

Fig. 8-9

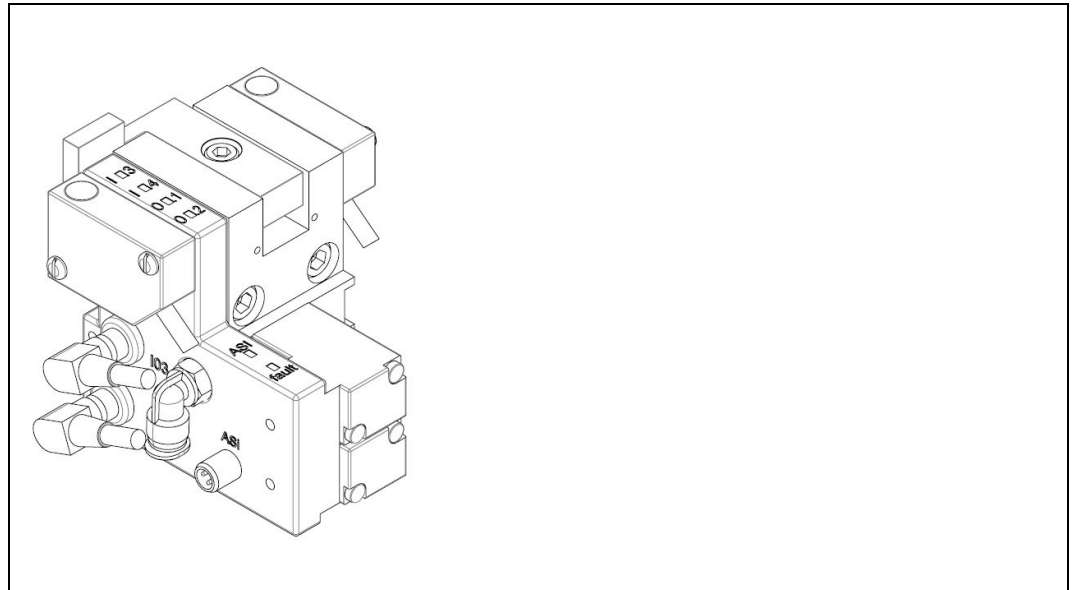
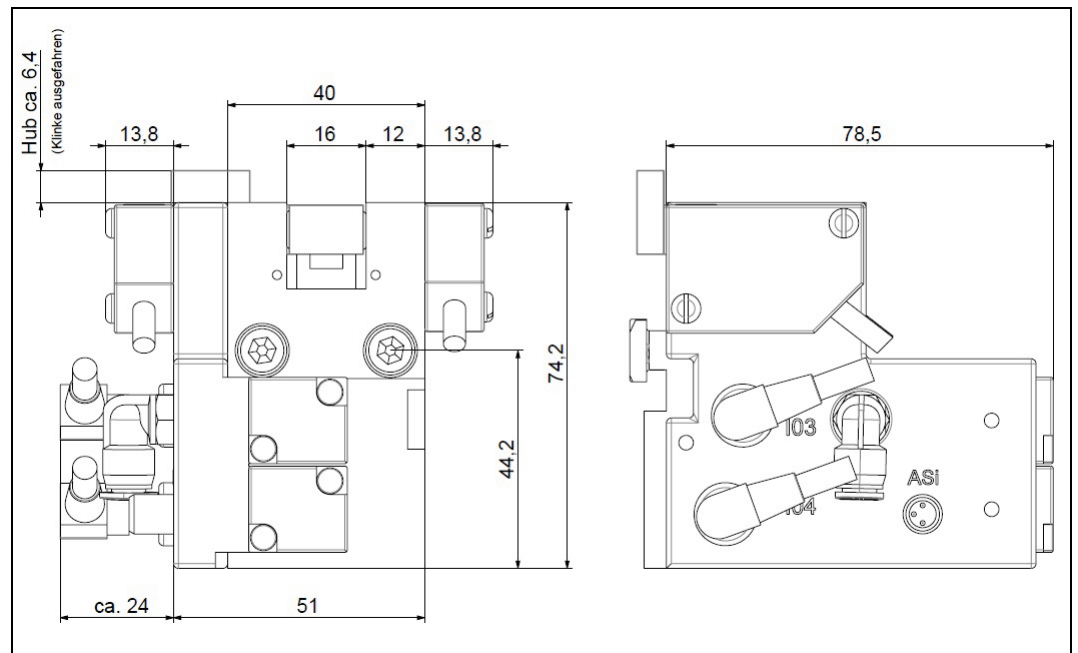

Fig. 8-10



8.7 300 426 001 ASI workstation stop device left (ASI-AS-L)

Fig. 8-11

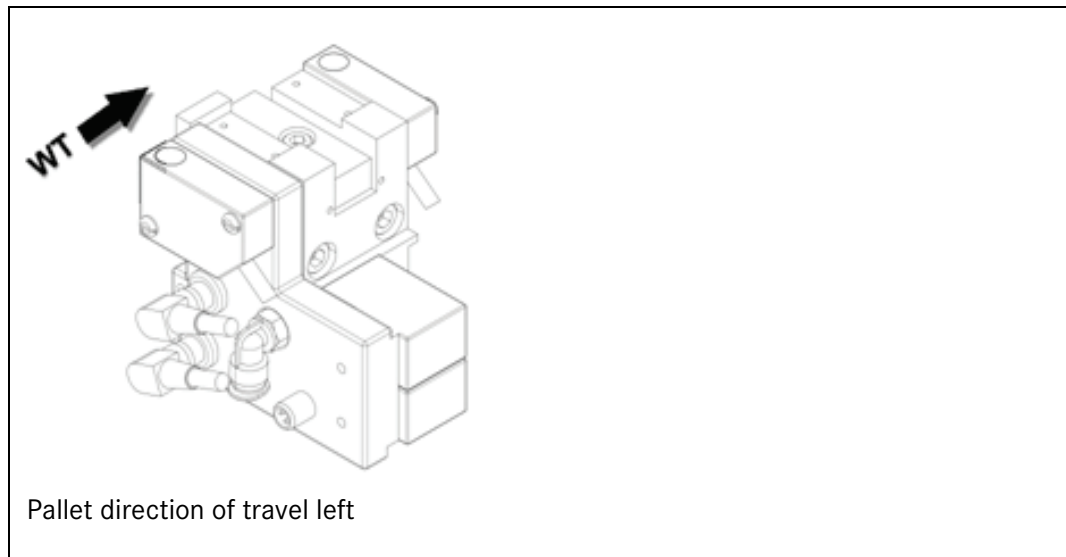
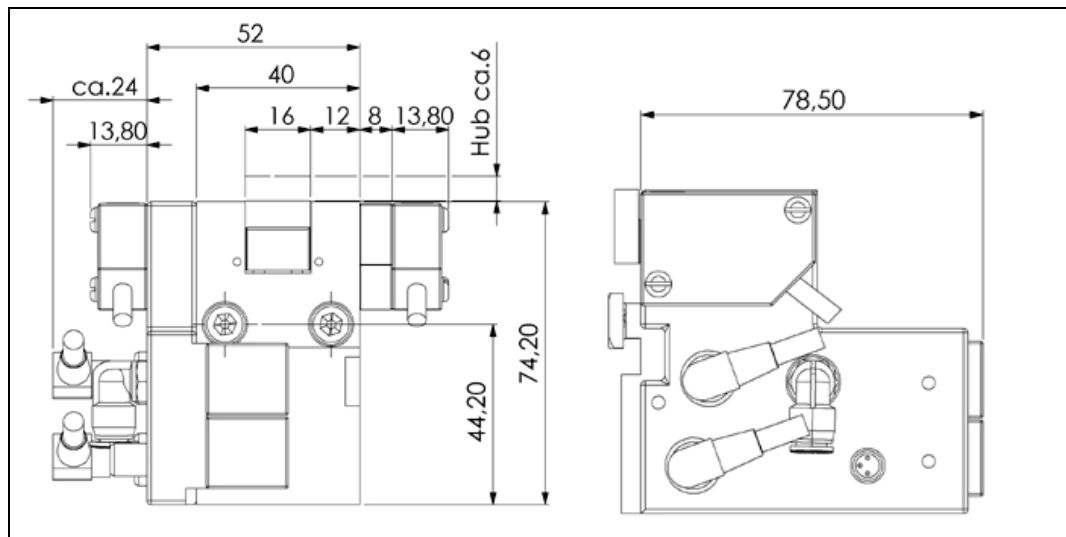

Fig. 8-12



8.8 300 427 001 ASI supply side stop device (ASI-ES)

Fig. 8-13

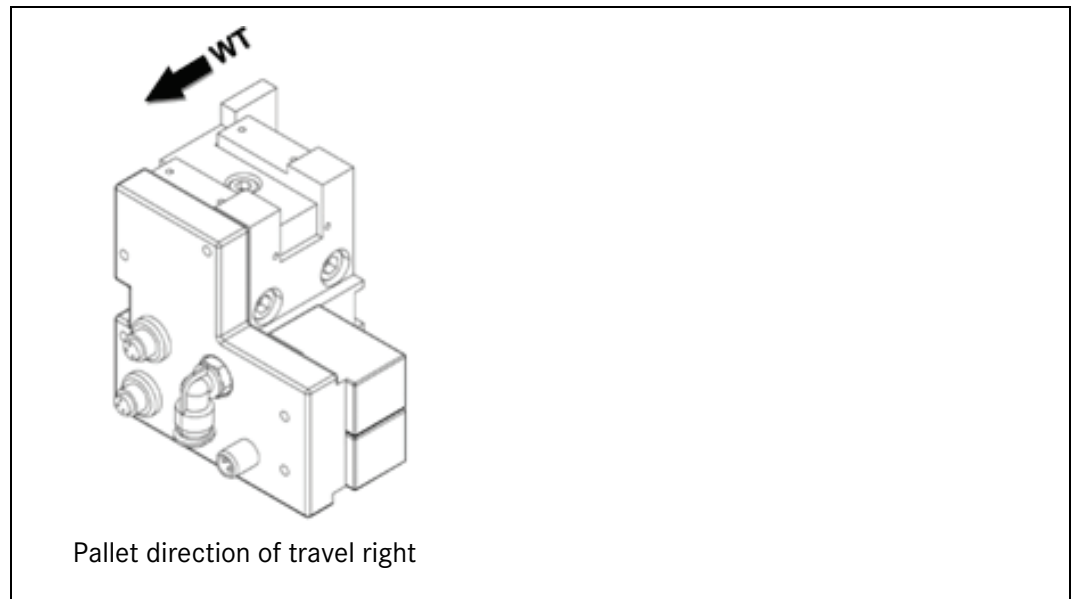
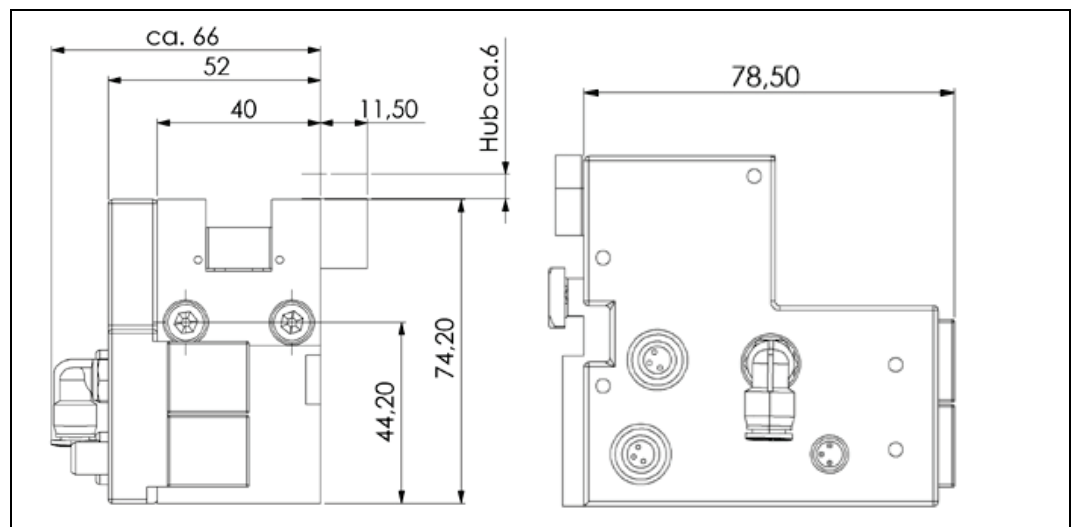

Fig. 8-14



8.9 300 428 001 ASI workstation stop device with offset stop (ASI-ASA)

Fig. 8-15

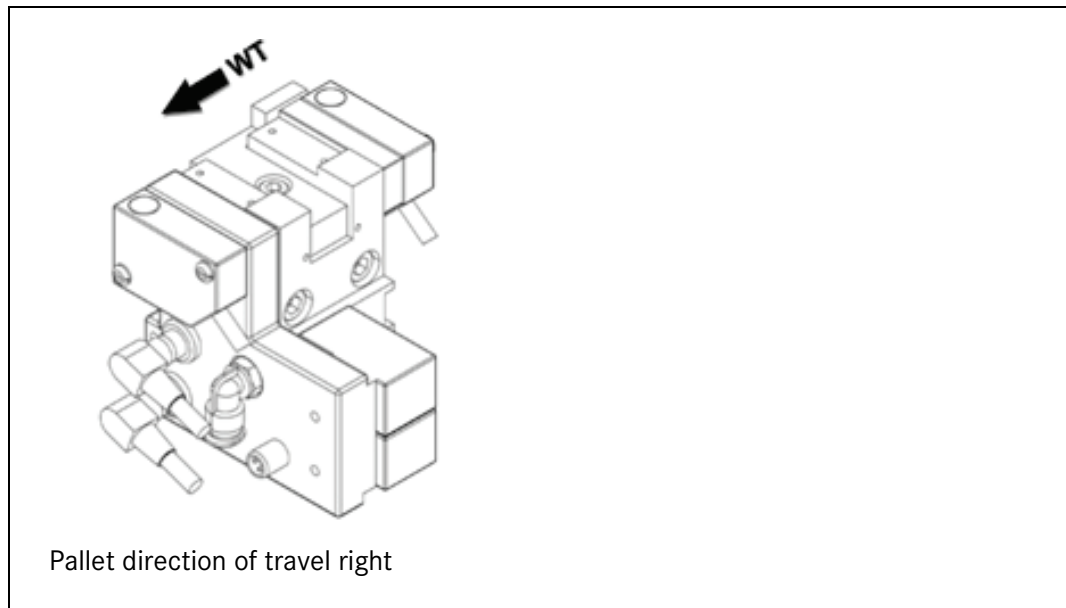
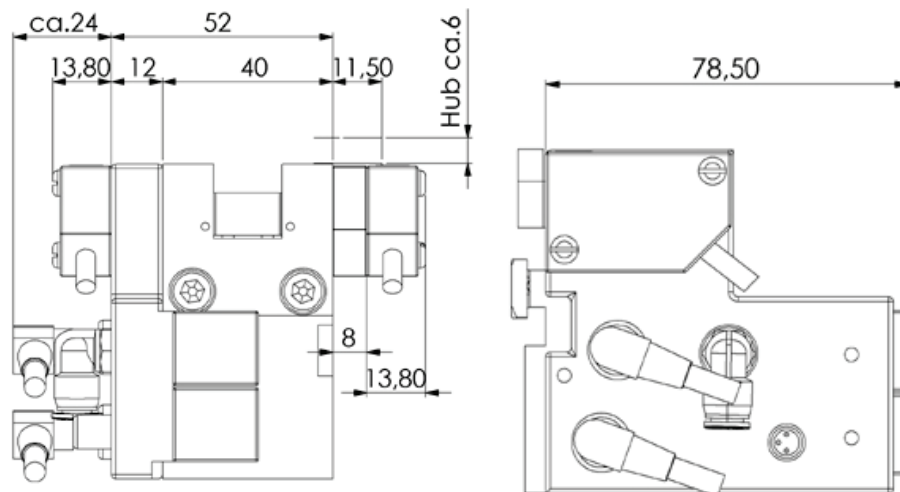

Fig. 8-16



8.10 300 429 001 ASI workstation stop device with offset stop (ASI-ASB)

Fig. 8-17

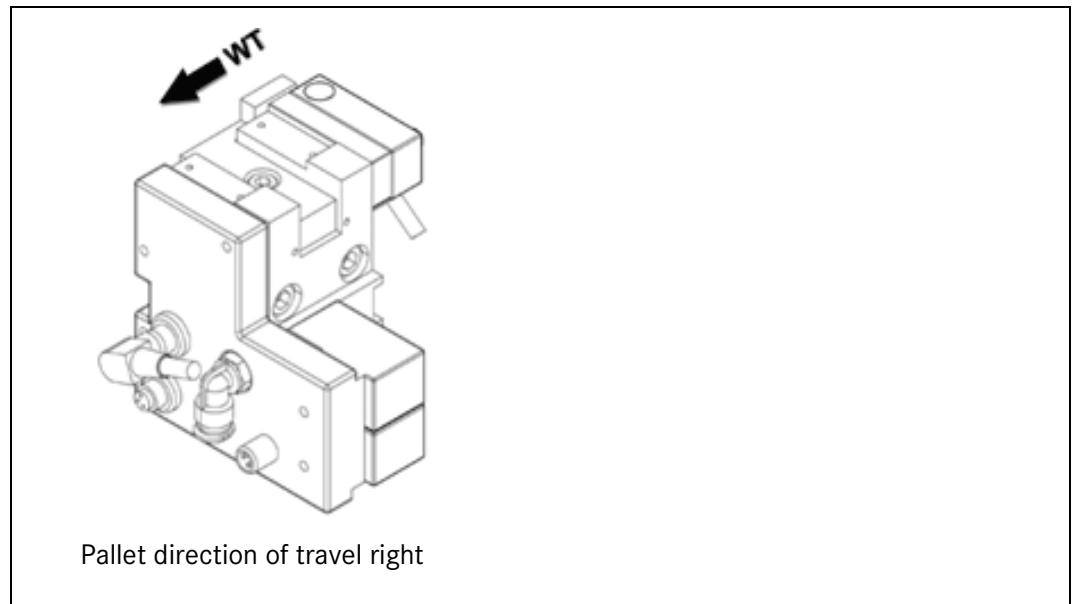
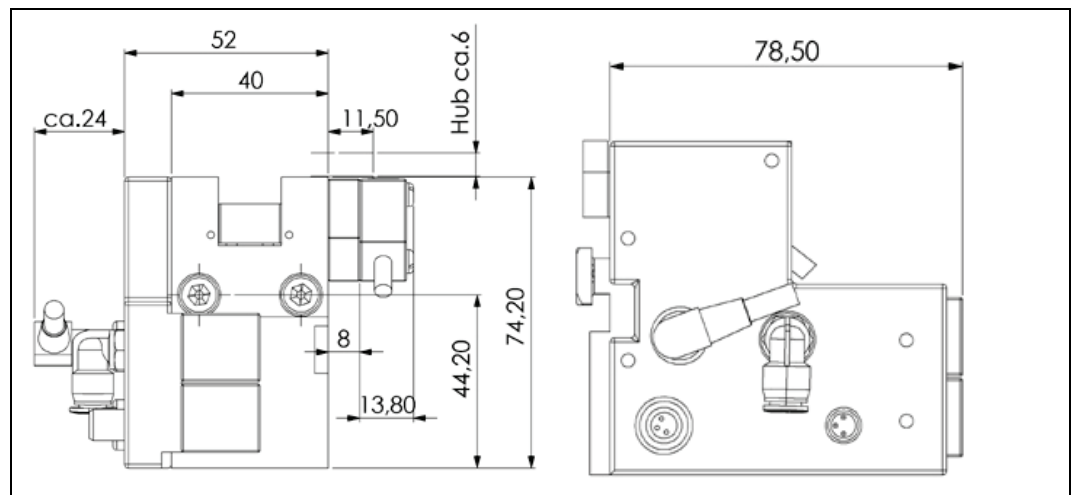

Fig. 8-18



8.11 300 429 001 ASI workstation stop device with offset stop (ASI-ASC)

Fig. 8-19

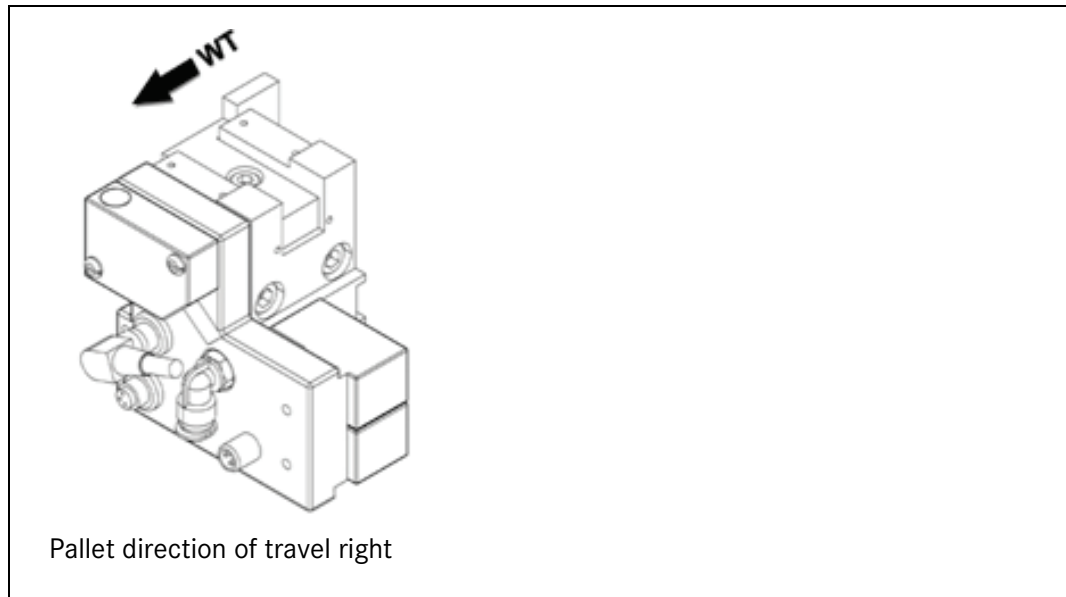
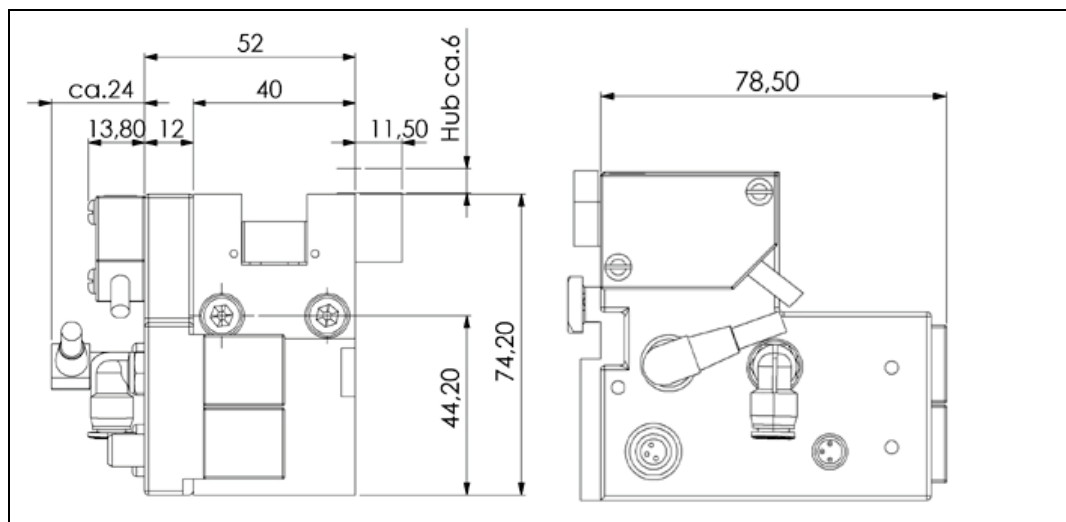

Fig. 8-20



8.12 Components of the accessory items

8.12.1 300 441 001 Switch underneath (ASI-SU)

Fig. 8-21

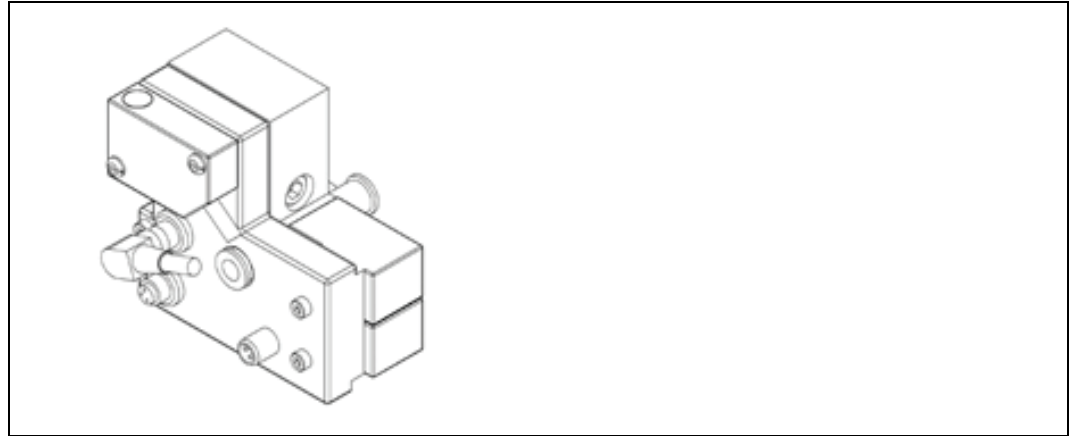
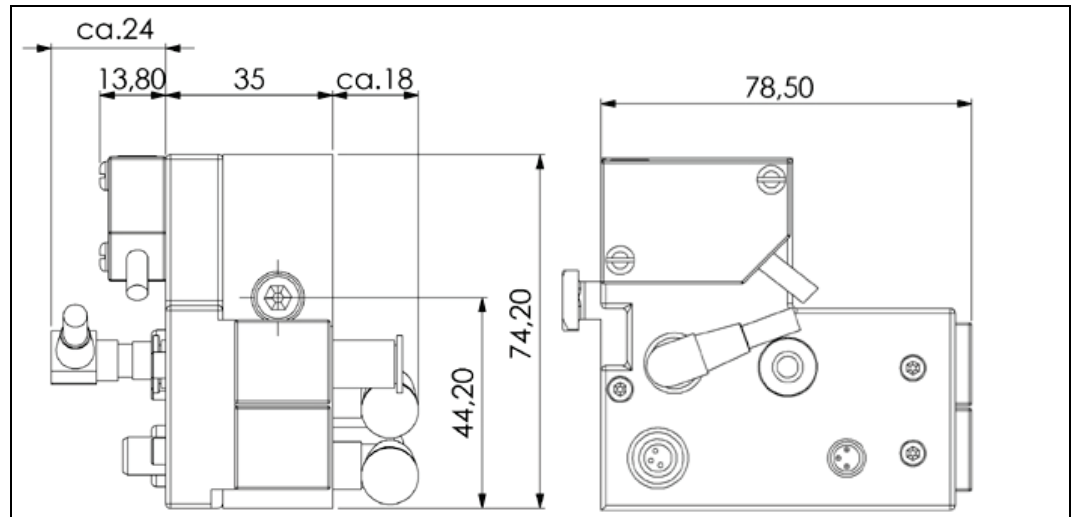

Fig. 8-22



8.12.2 300 520 001 ASI valve (AVB)

Fig. 8-23

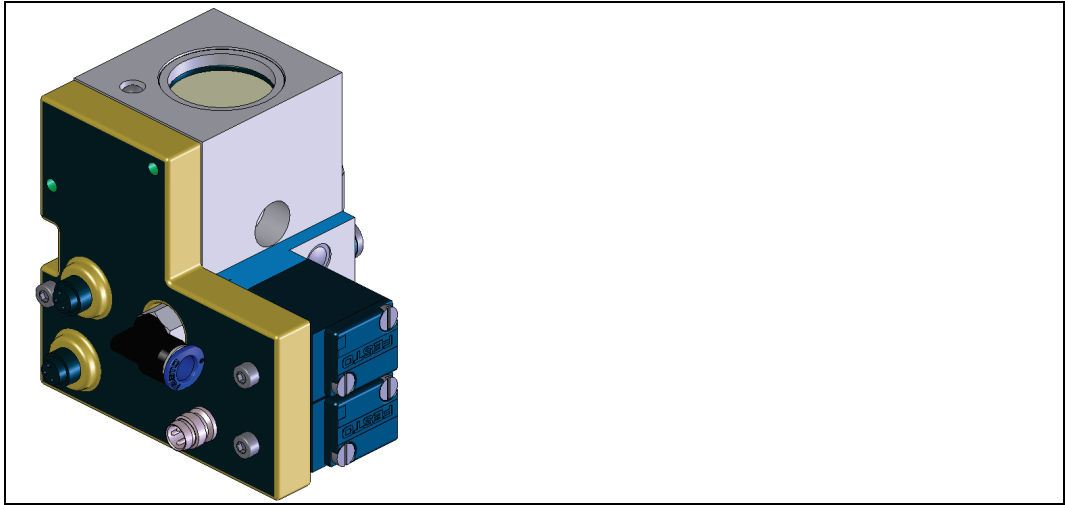
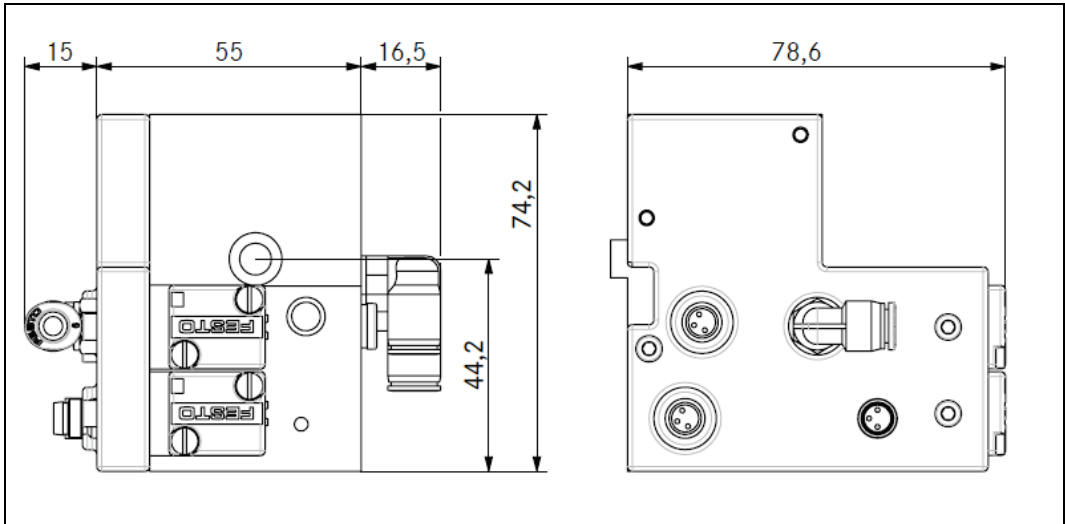
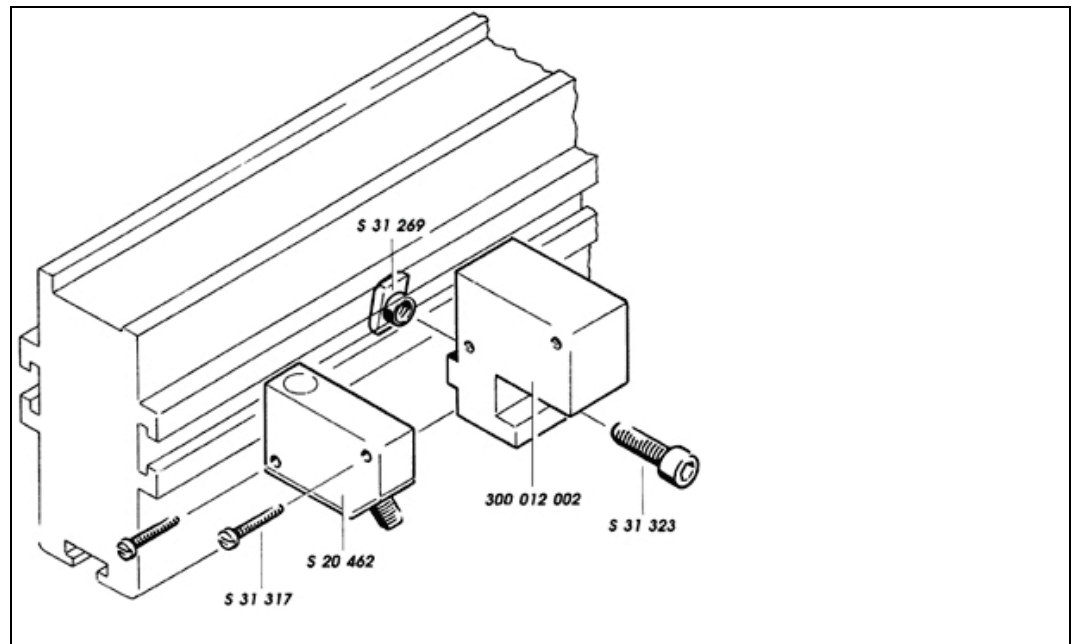

Fig. 8-24



8.12.3 300 012 001 ASI switch, bottom (SU)

Fig. 8-25



8.12.4 300 688 001 Trigger switch ASI

Fig. 8-26

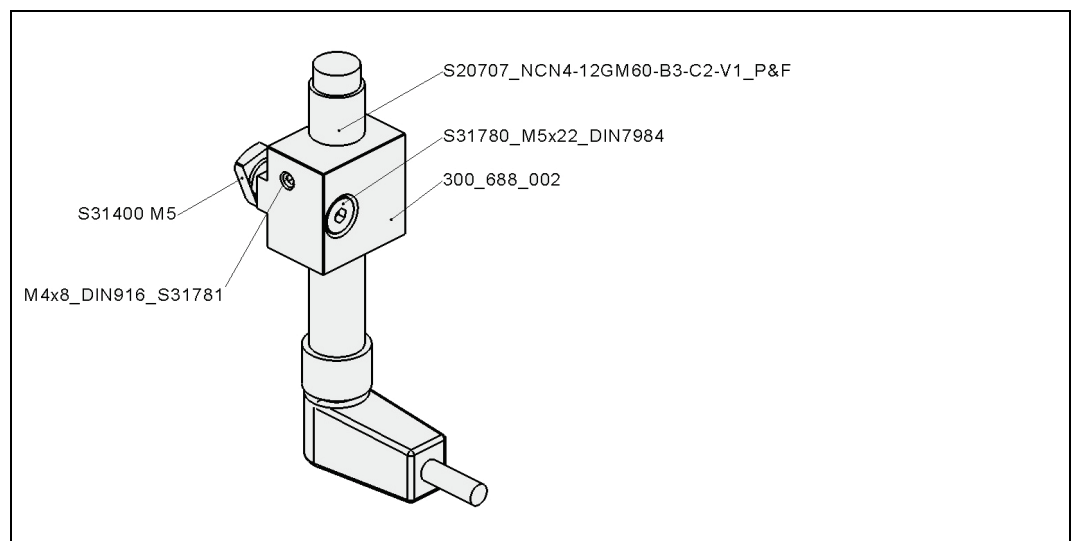

8.12.5 300 055 001 Stop device (SEAE)

Fig. 8-27

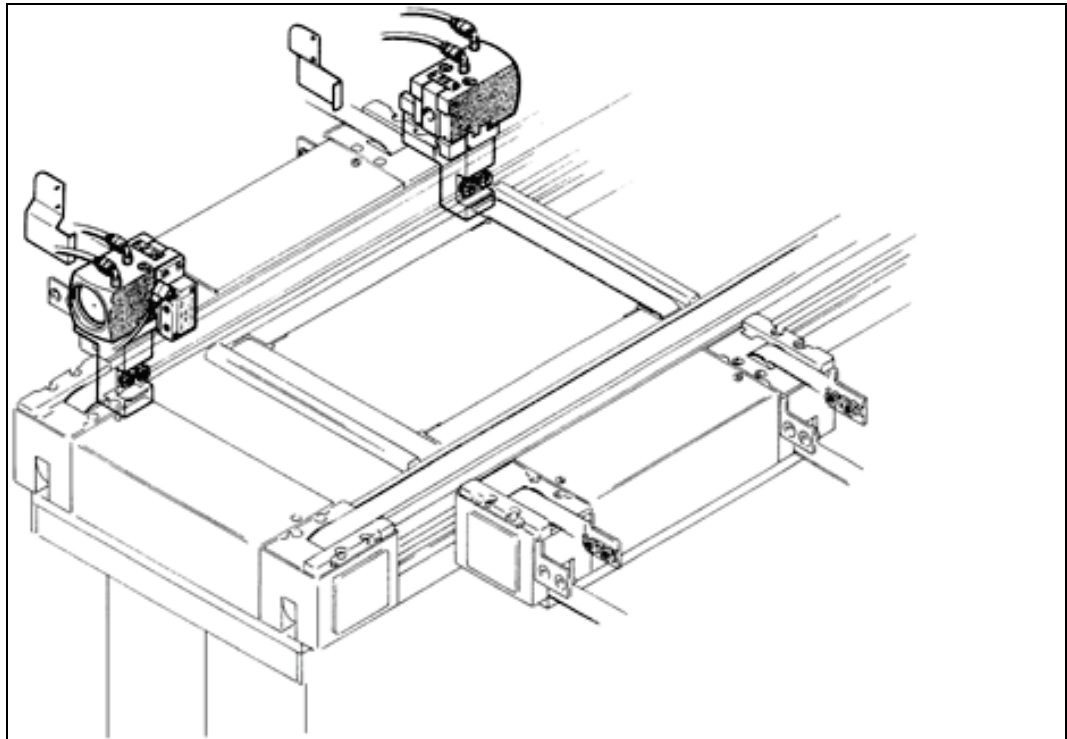

8.12.6 300 056 001 Switch holder (SEA)

Fig. 8-28

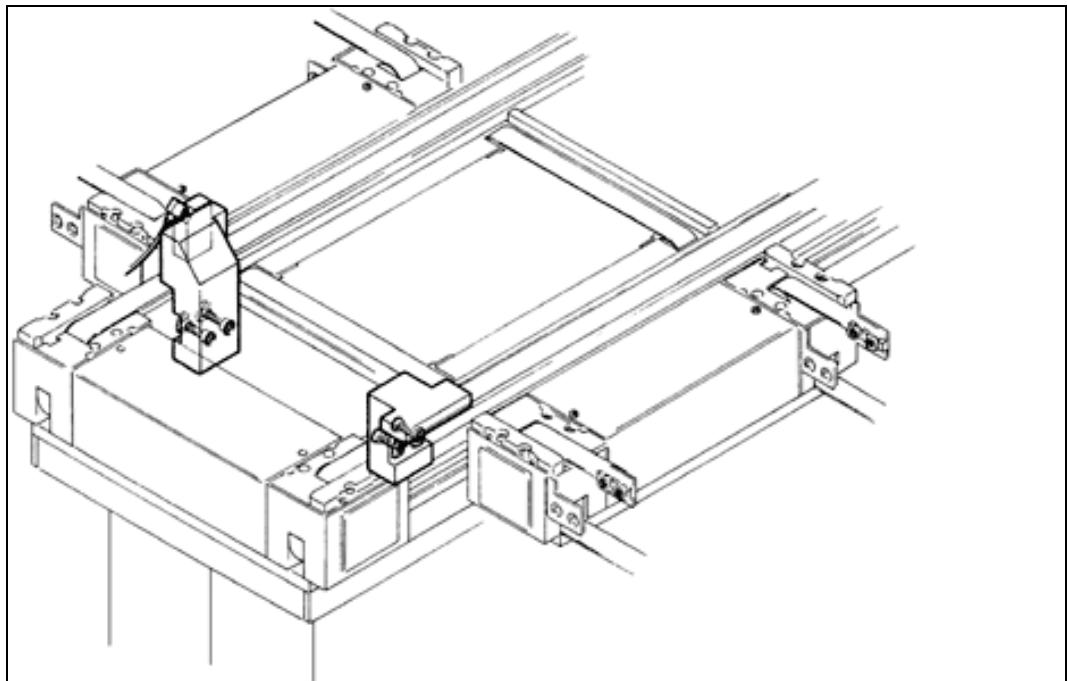

8.12.7 300 013 001 Switch - external (SA)

Fig. 8-29

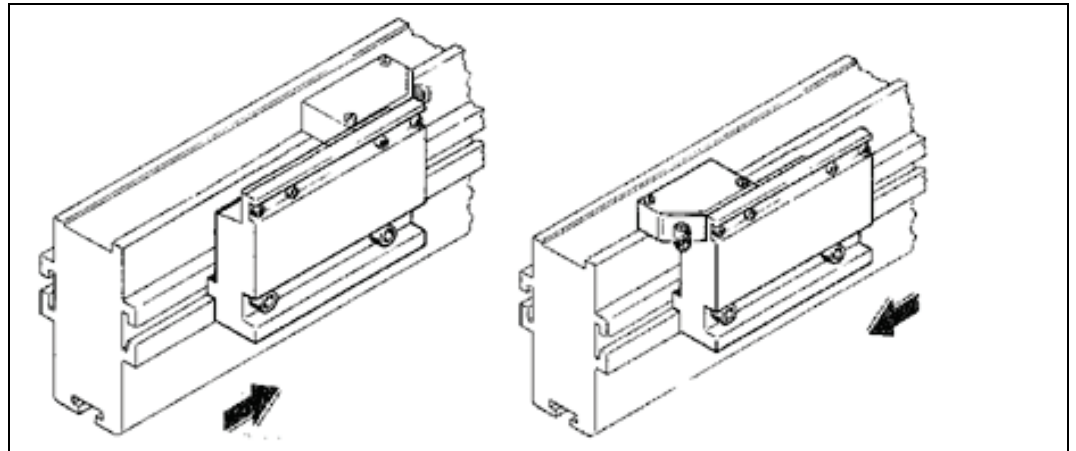
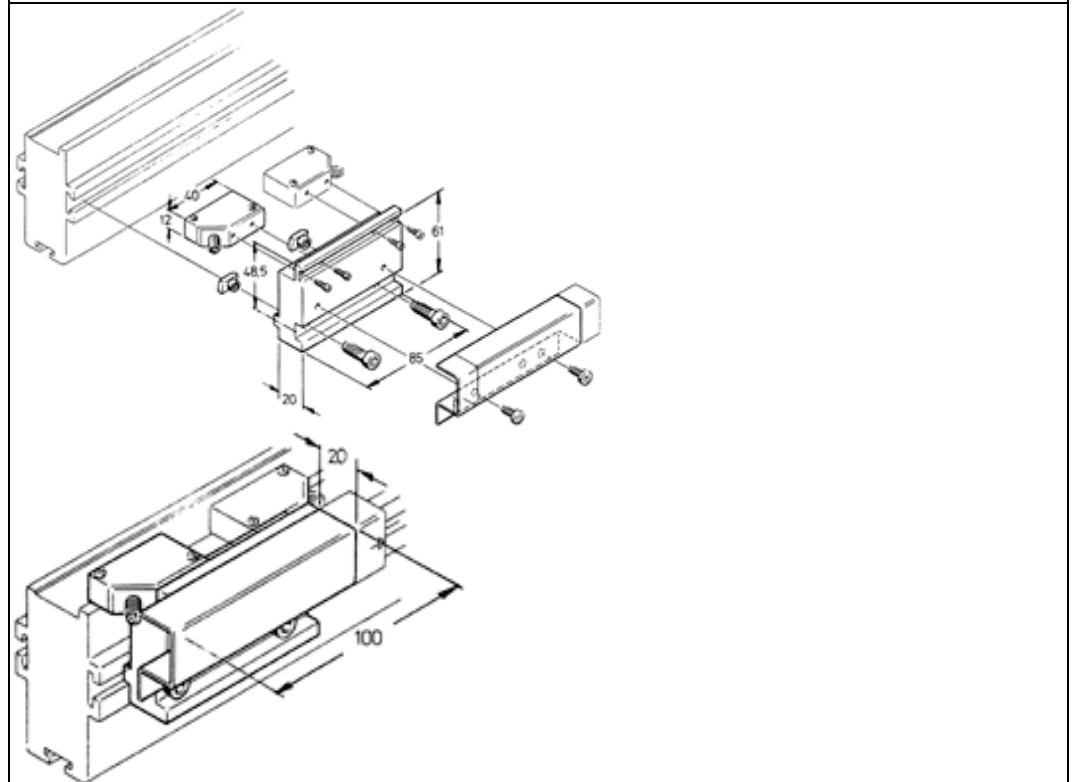
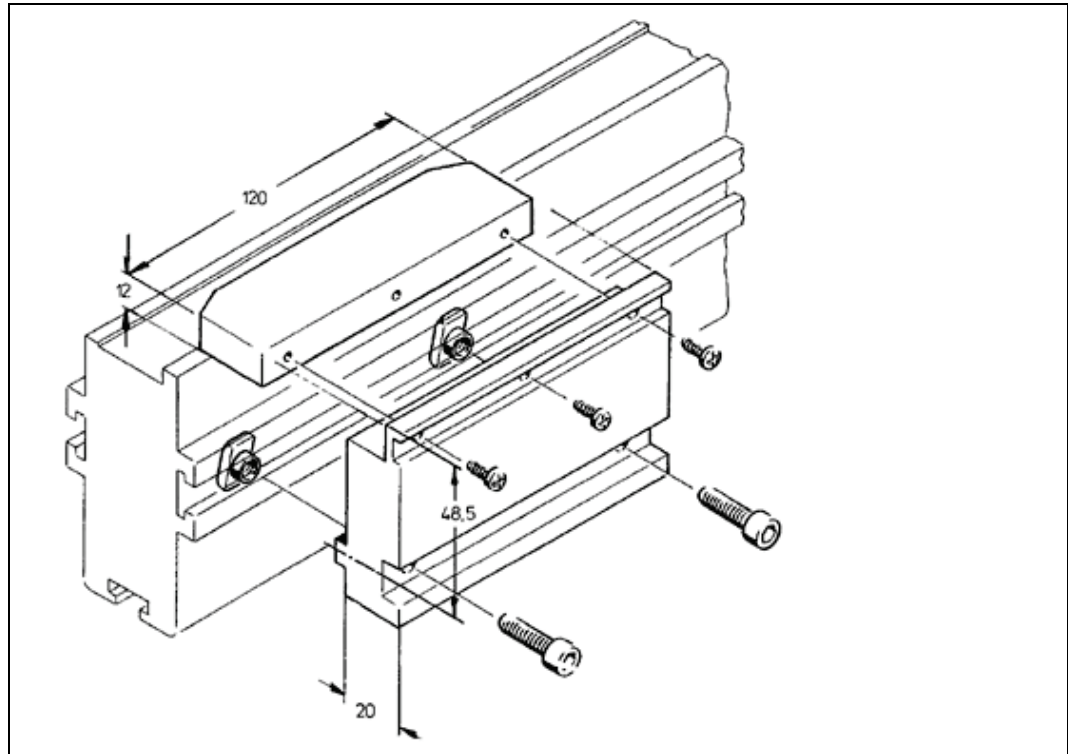

Fig. 8-30



8.12.8 300 015 001 Stop - external (AA)

Fig. 8-31



8.12.9 300 016 001 Stop - internal (AI)

Fig. 8-32

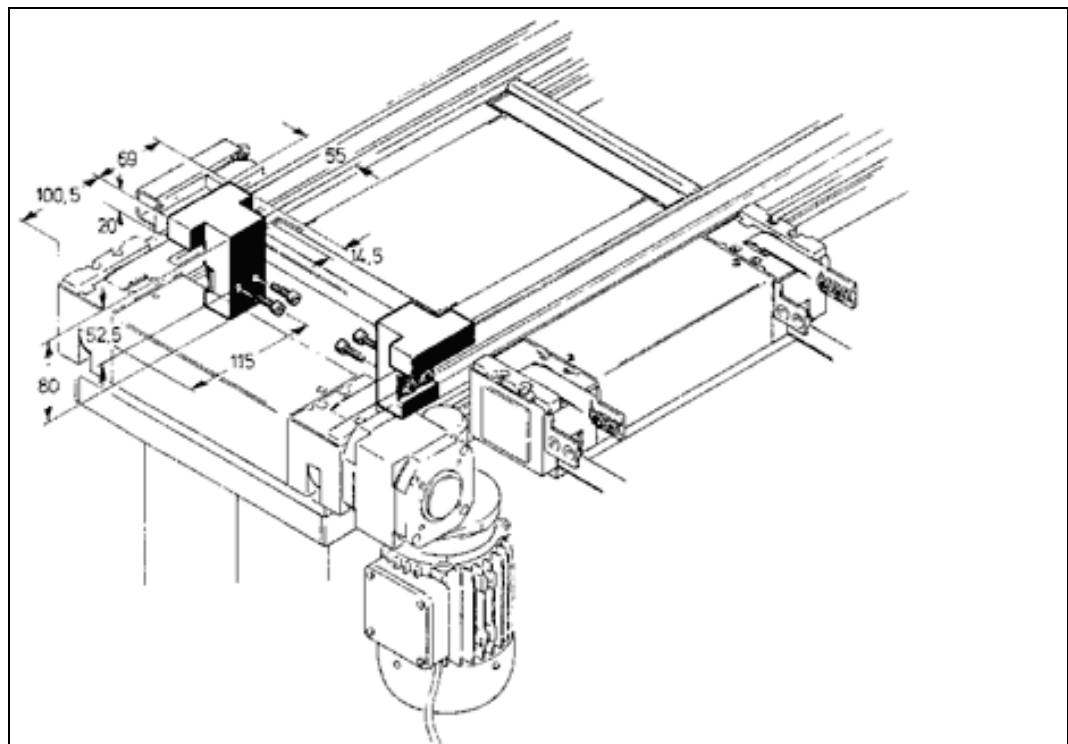

8.12.10 Retention lock – pallet

i

The retention lock prevents the manual pushing of the pallet against the driving direction to or from the processing position.

Fig. 8-33

300 274 001

Retention lock – pallet
after workstation

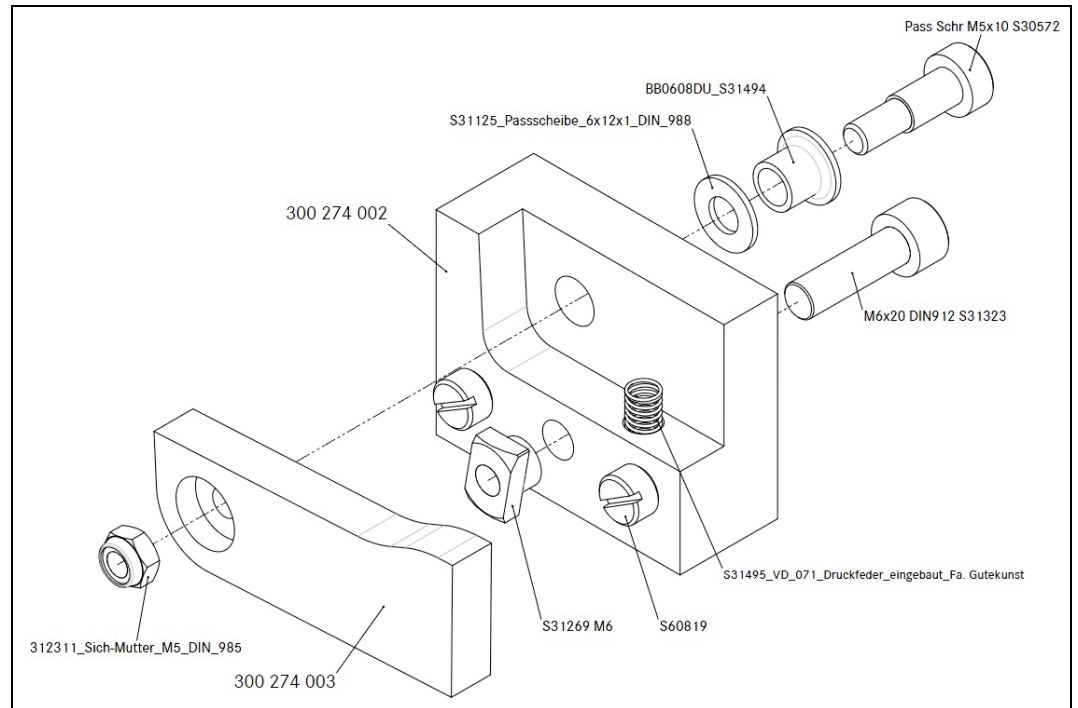

Fig. 8-34

300 275 001

Retention lock – pallet in
workstation

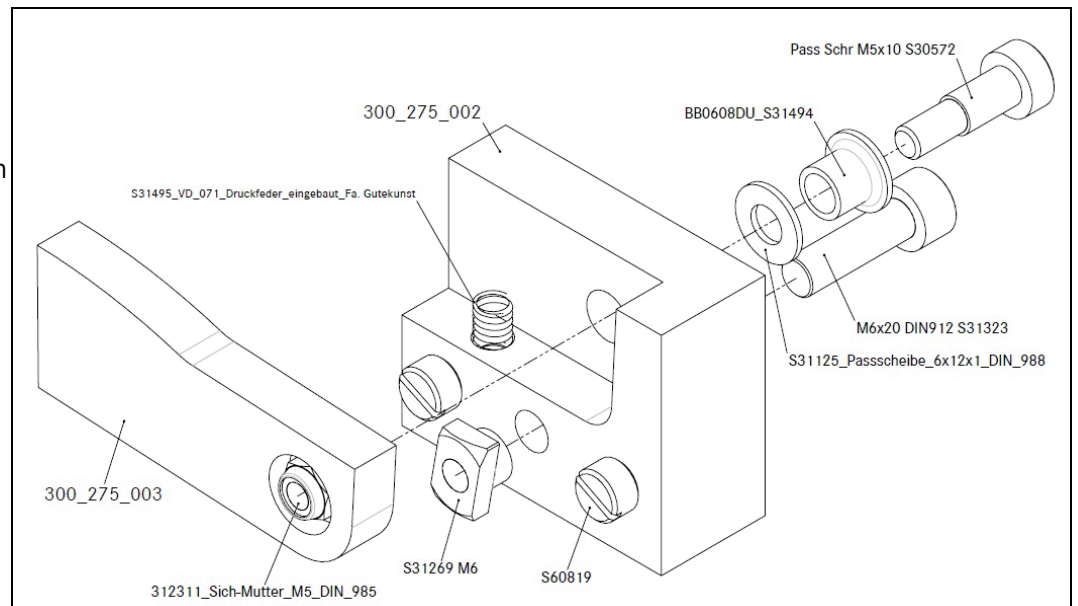

Fig. 8-35

300 274 001

Retention lock - pallet in
workstation

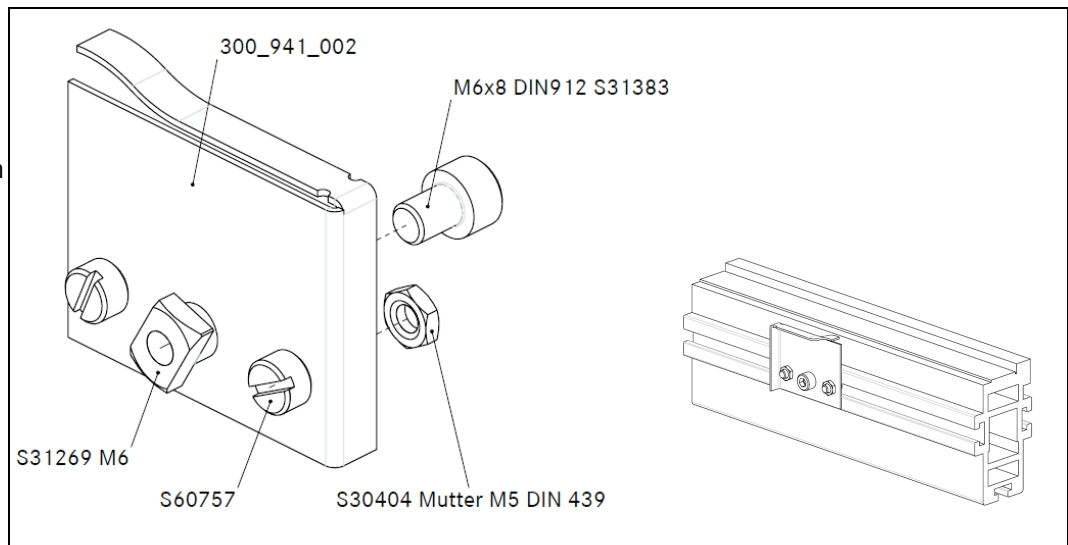

Fig. 8-36

300 275 001

Retention lock - pallet
after workstation

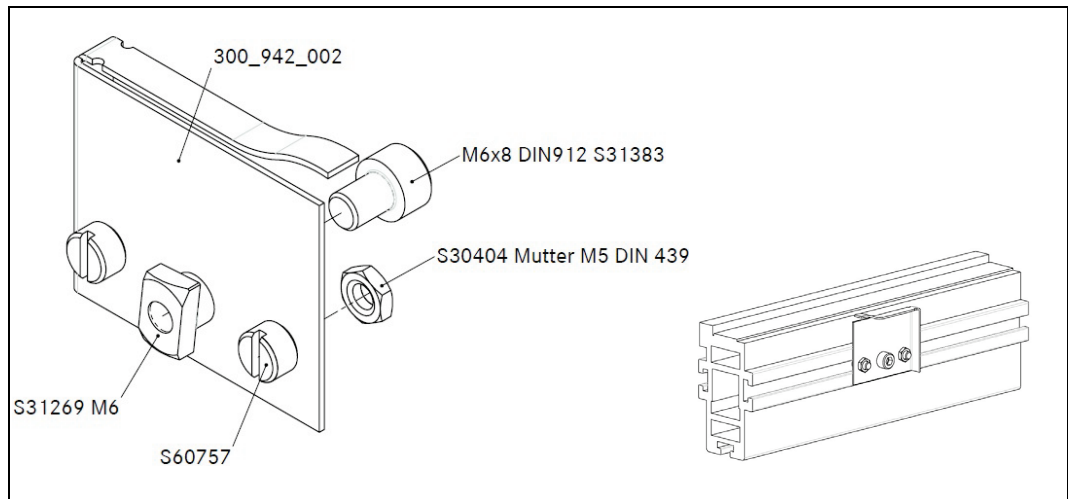
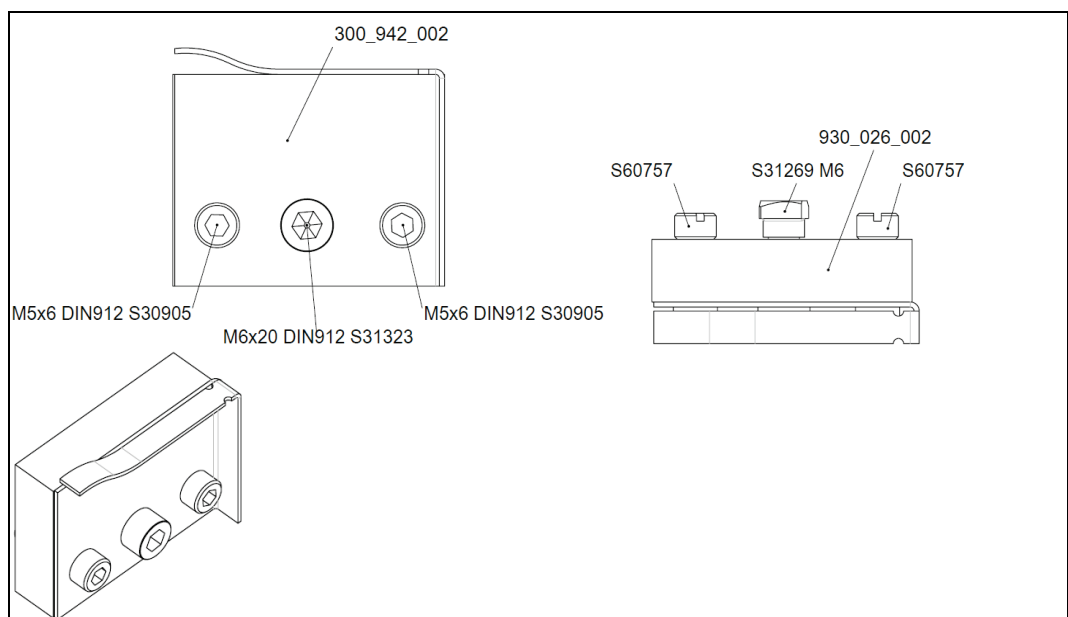

Fig. 8-37

930 026 001

Retention lock pallet
right - indented



9 P-Positions Soft Move

9.1 P1S / P3S (Corner 90° BE→QE)

Fig. 9-1

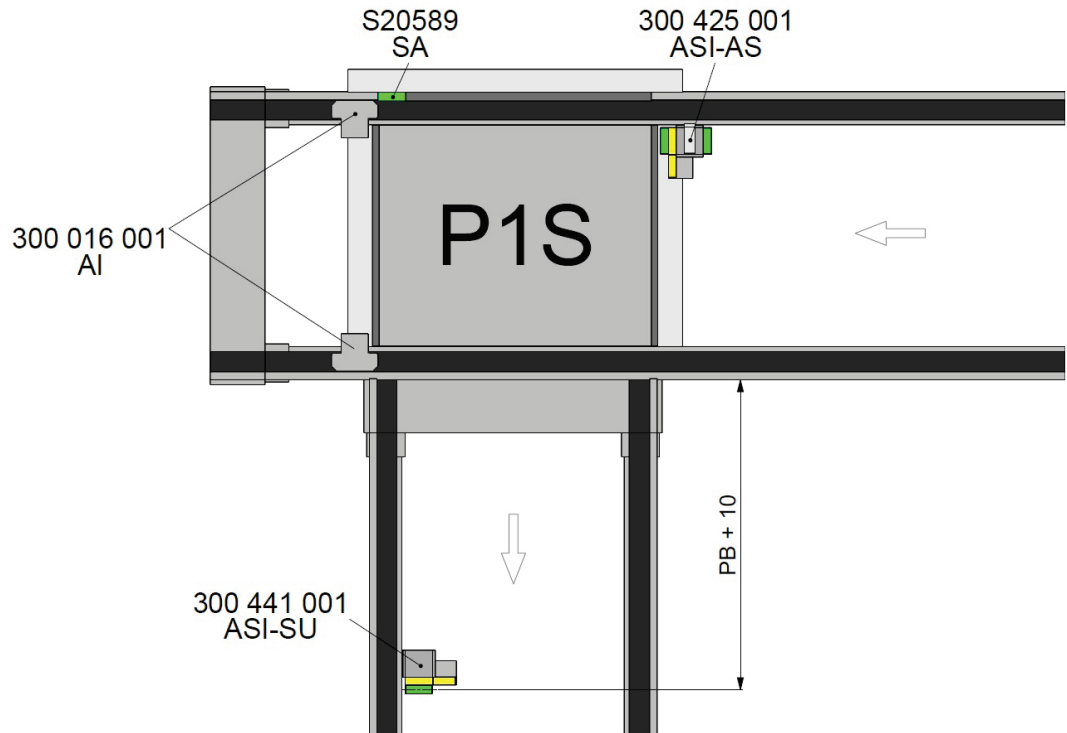
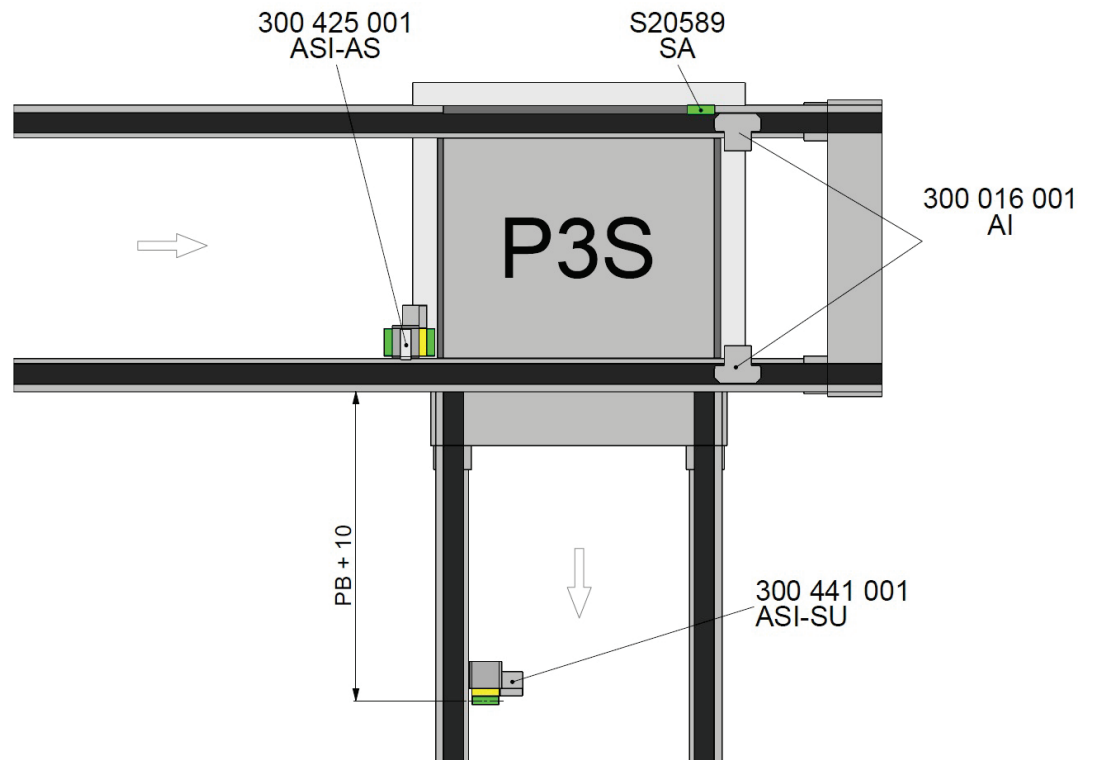

Fig. 9-2



9.2 P2S / P4S (Corner 90° QE→BE)

Fig. 9-3

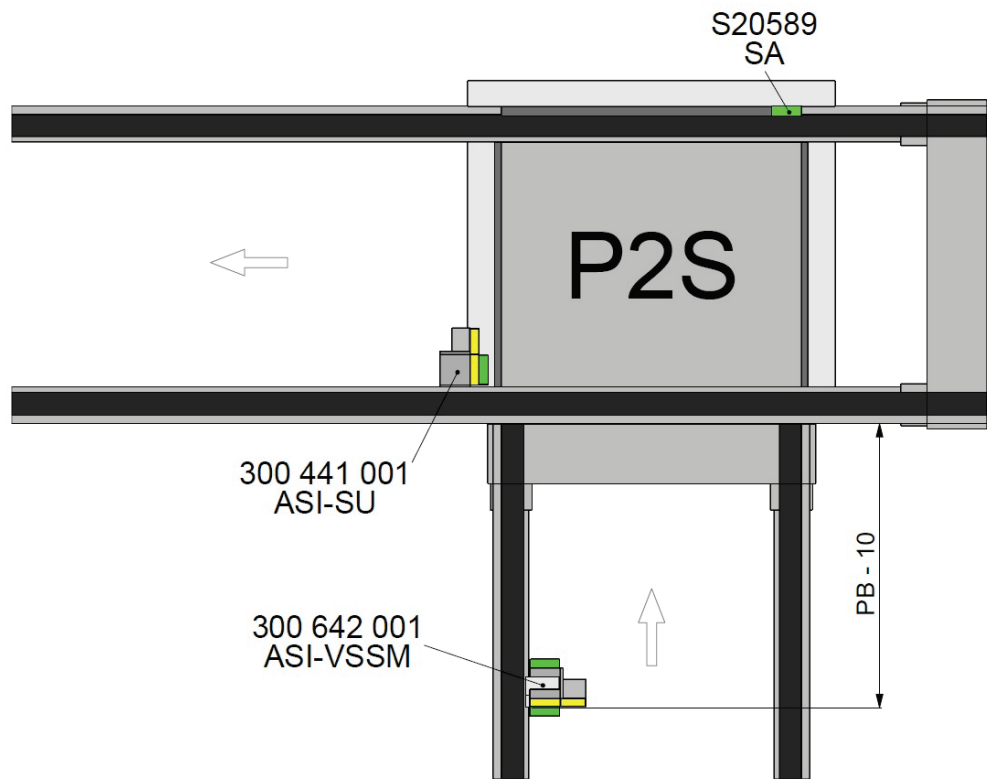
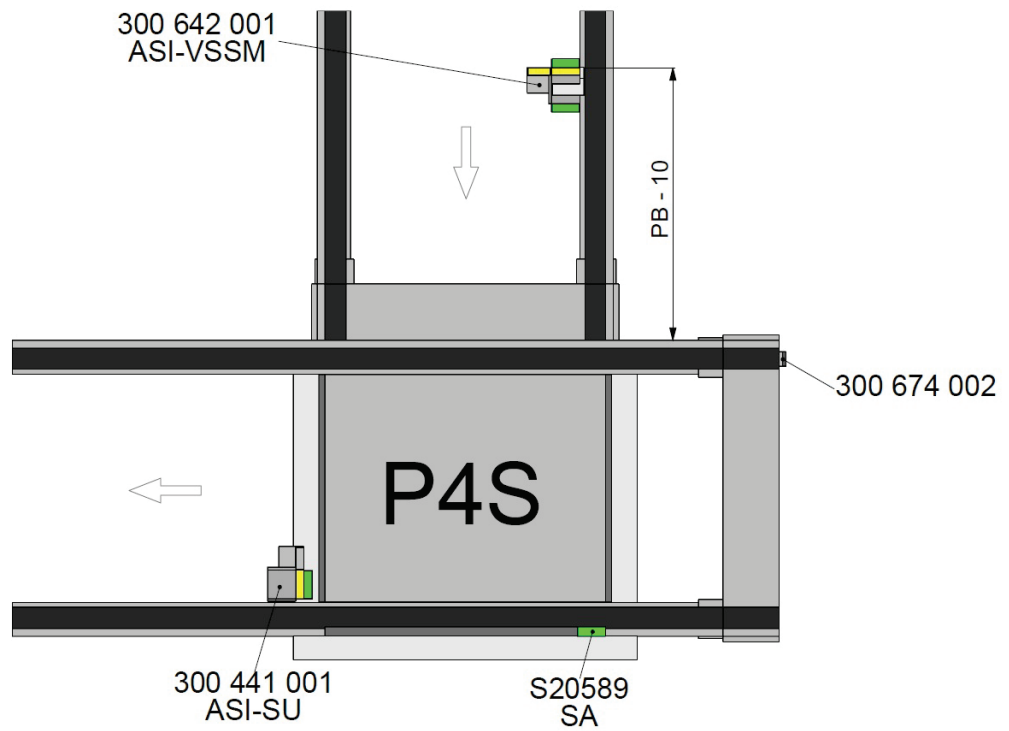

Fig. 9-4



9.3 P5S / P7S (A-workstation entry)

Fig. 9-5

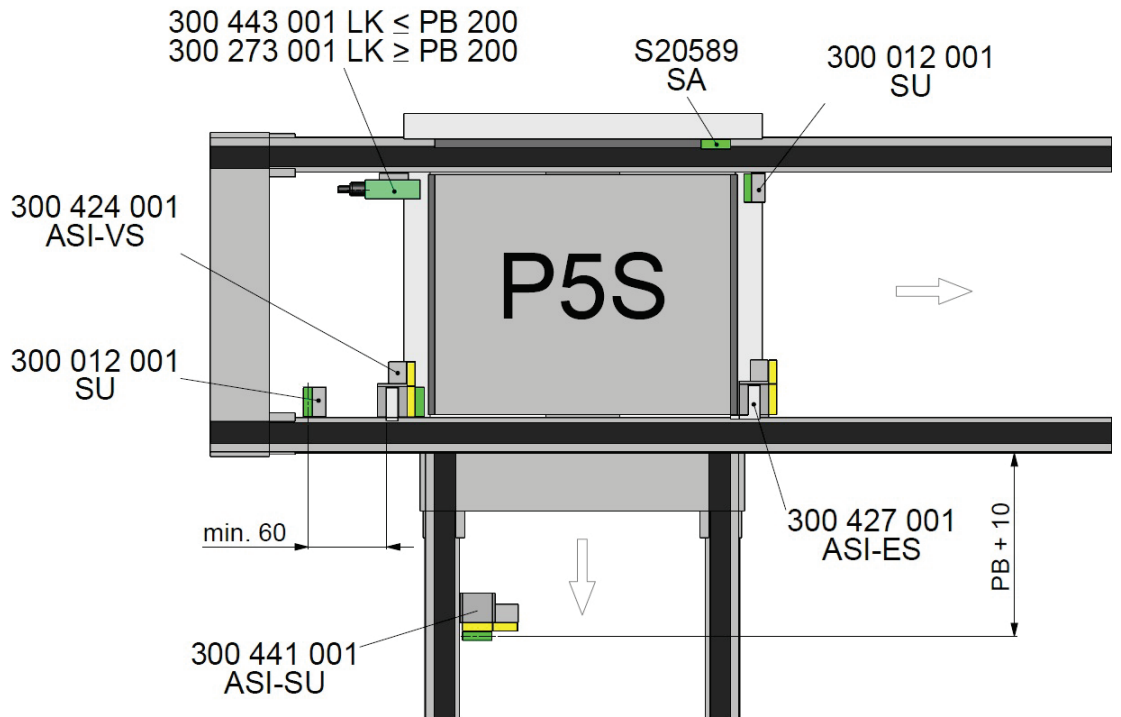
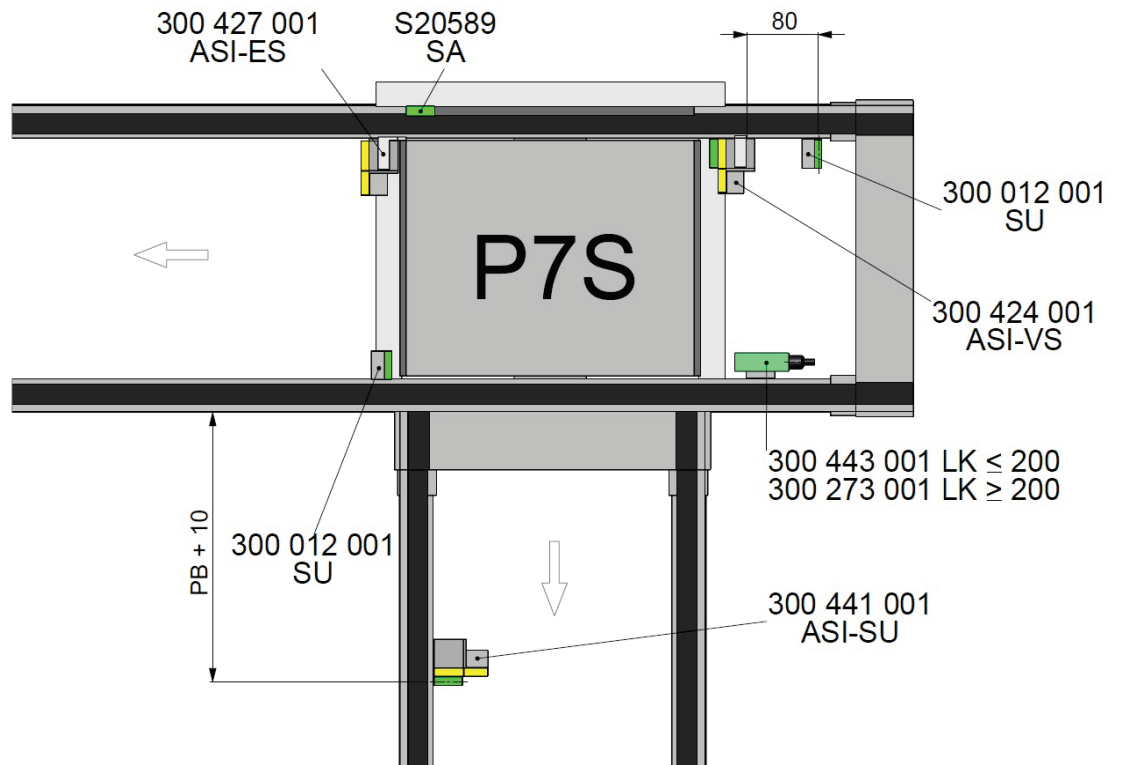

Fig. 9-6



9.4 P6S / P8S (A-workstation exit)

Fig. 9-7

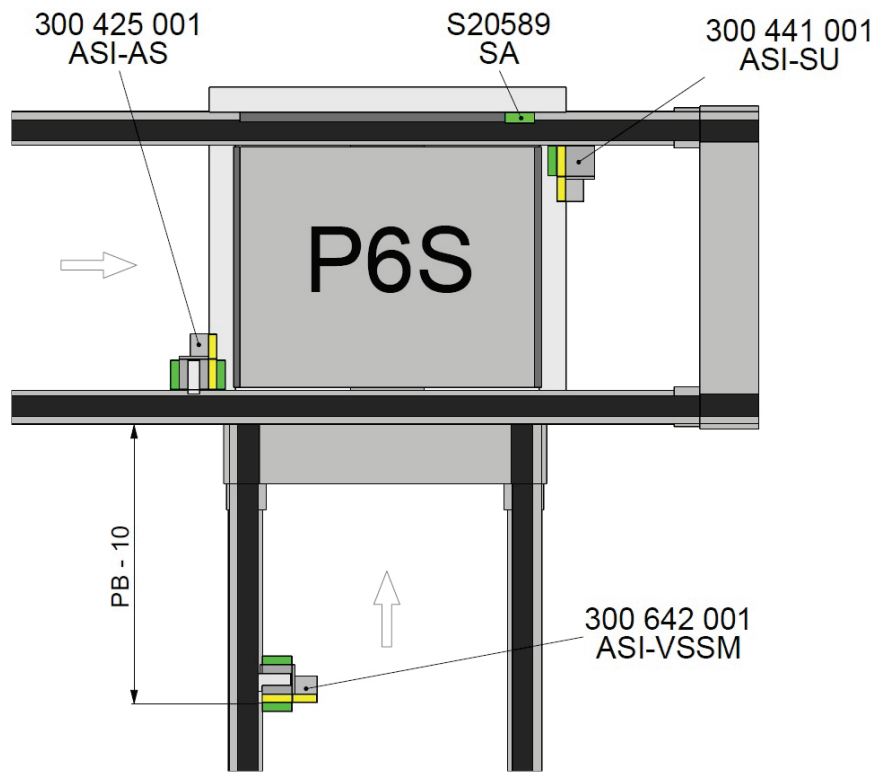
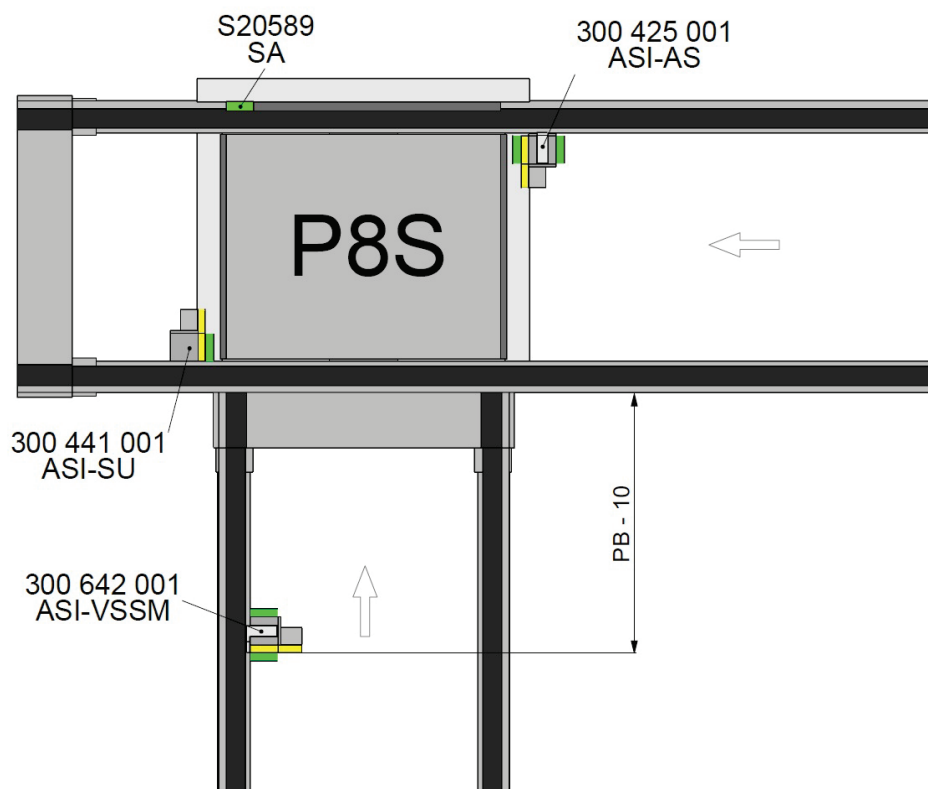

Fig. 9-8



9.5 P9S / P10S (Corner 180°)

Fig. 9-9

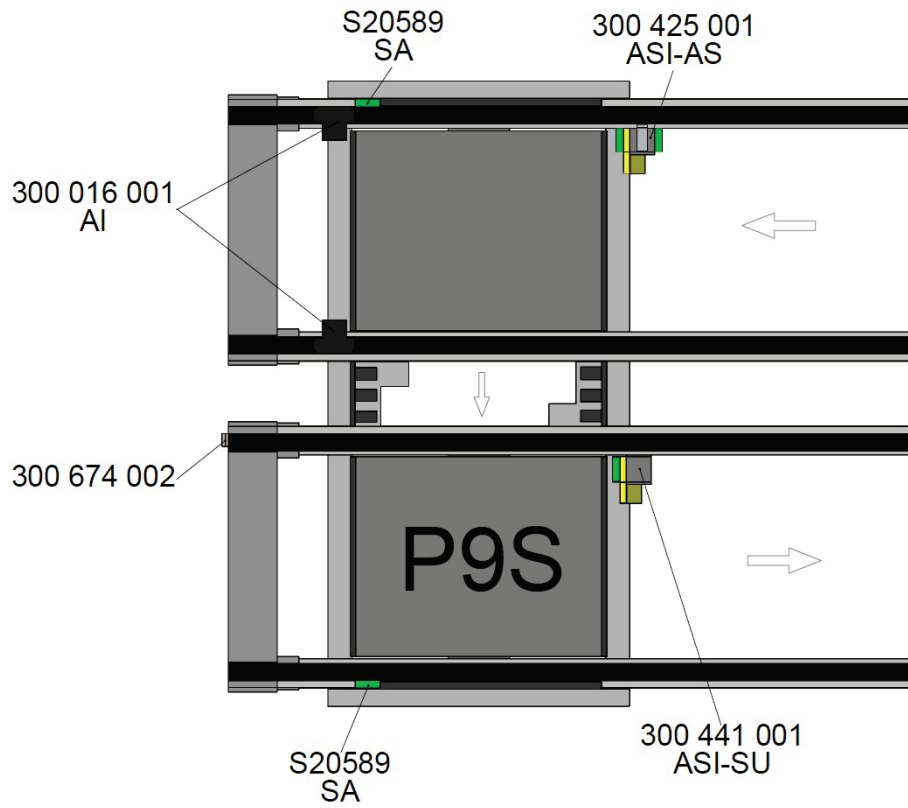
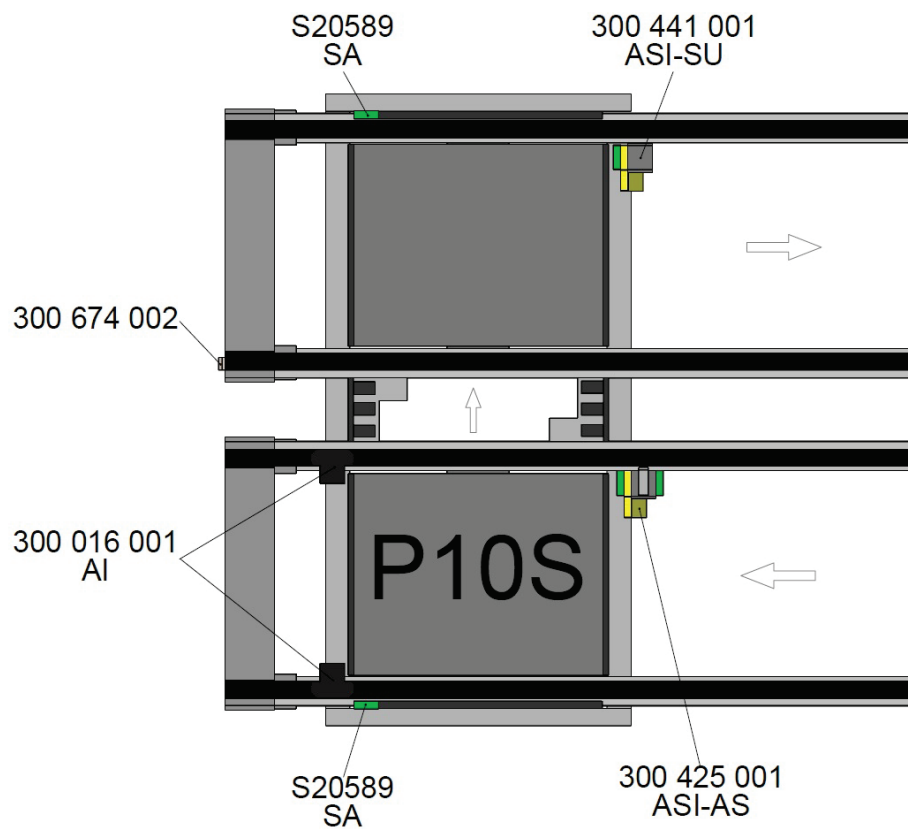

Fig. 9-10



9.6 P11S / P12S (B-workstation entry)

Fig. 9-11

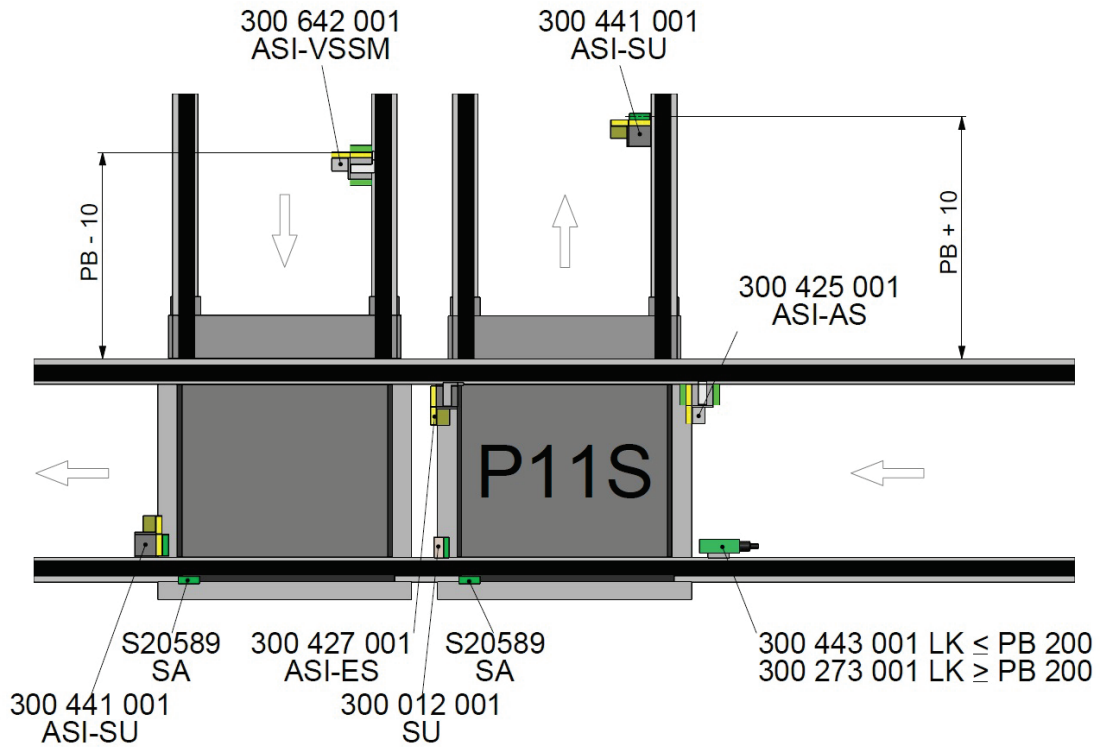
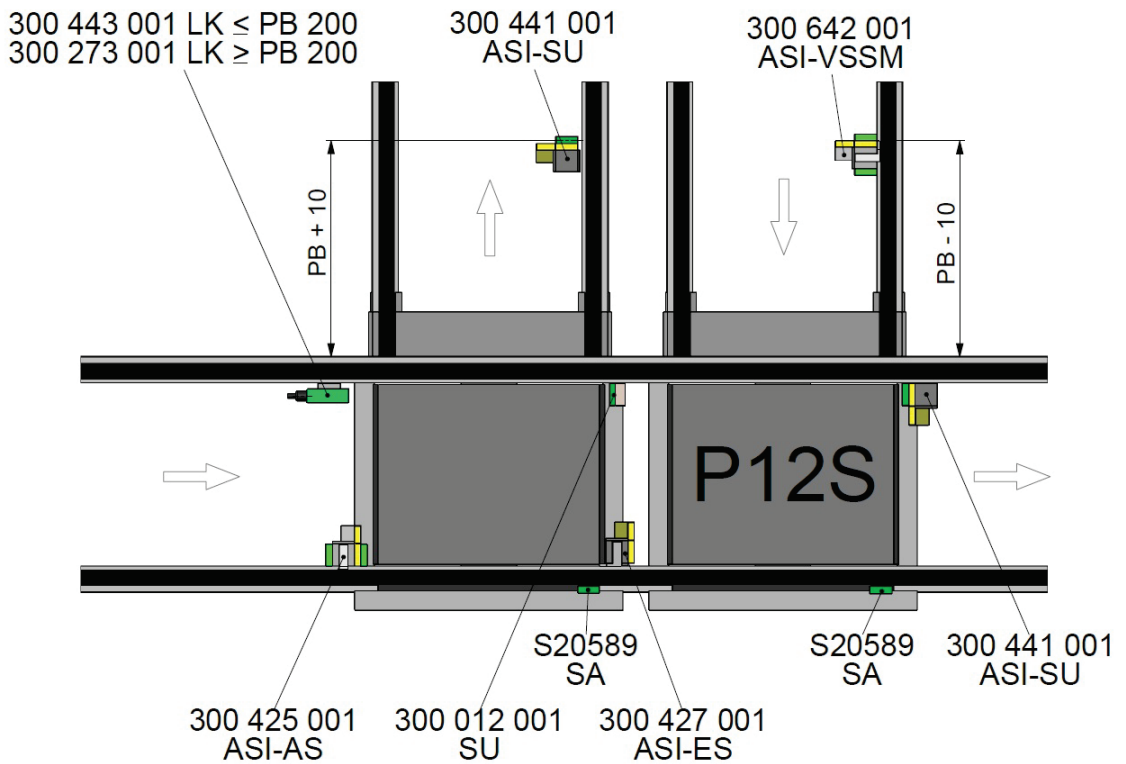

Fig. 9-12



9.7 P13S / P15S (C-workstation entry)

Fig. 9-13

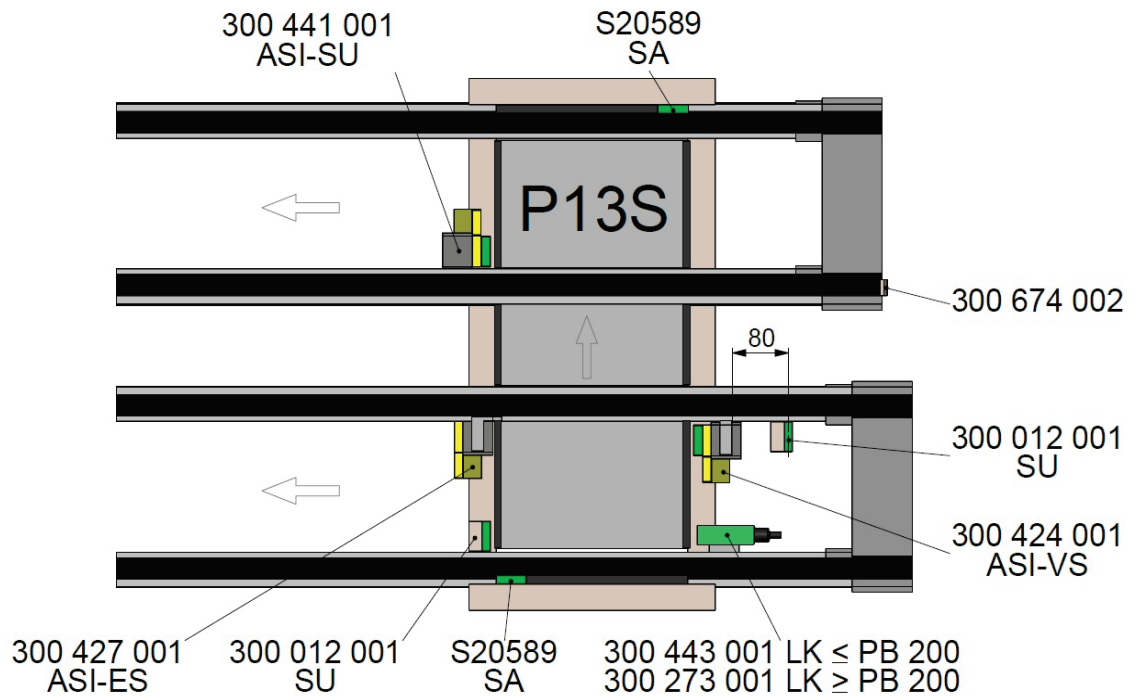
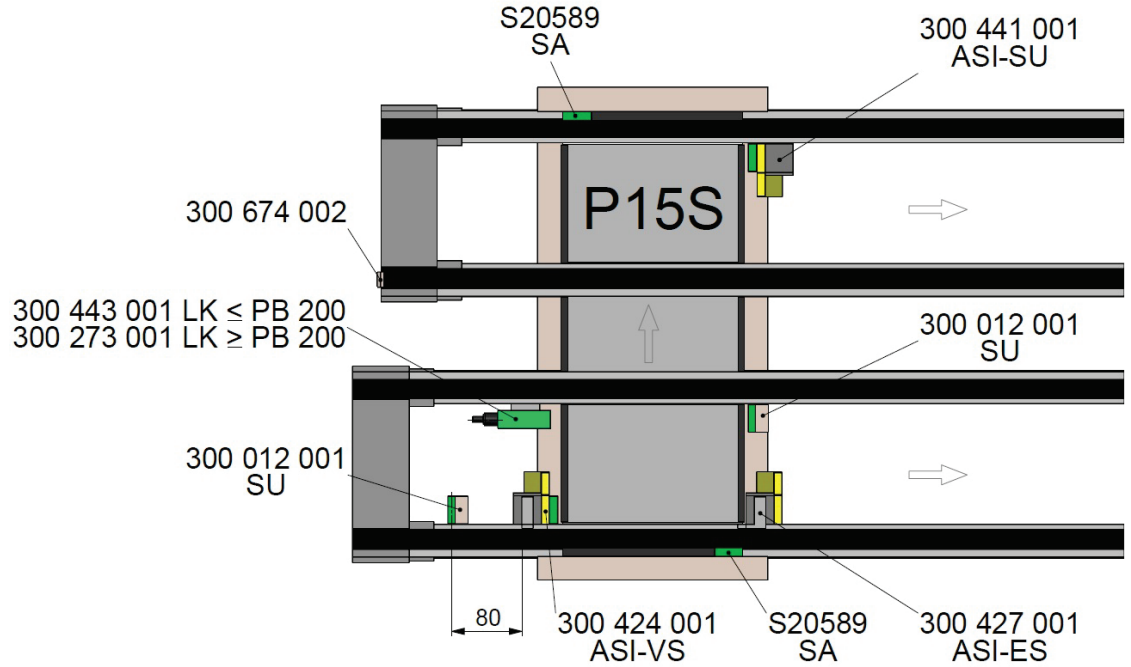

Fig. 9-14



9.8 P14S / P16S (C-workstation exit)

Fig. 9-15

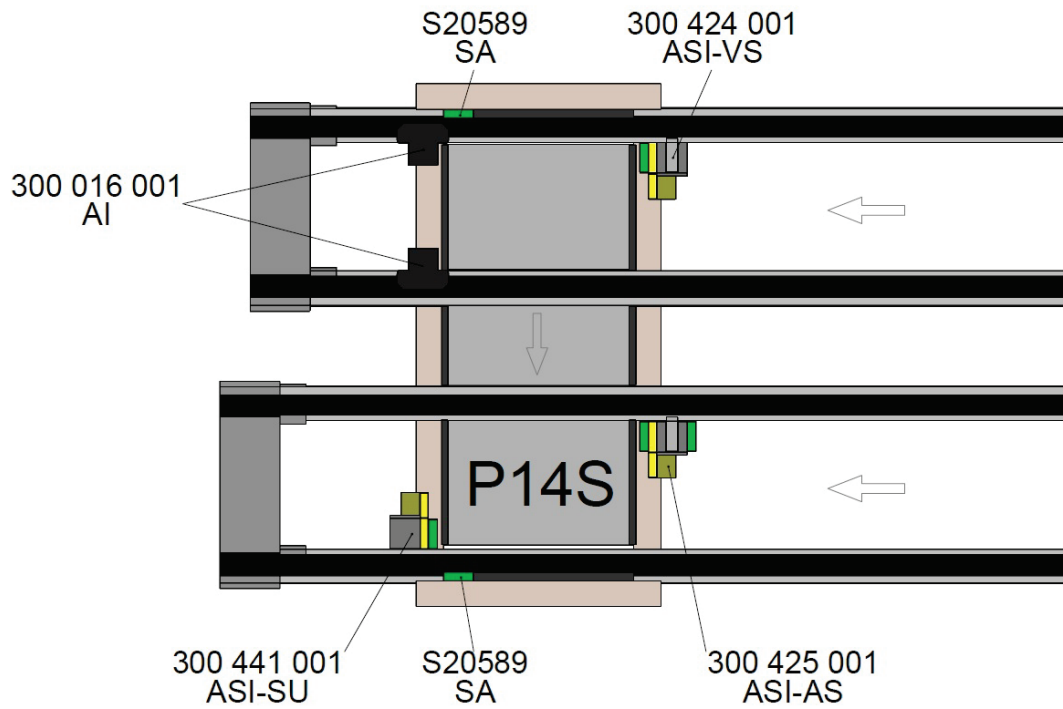
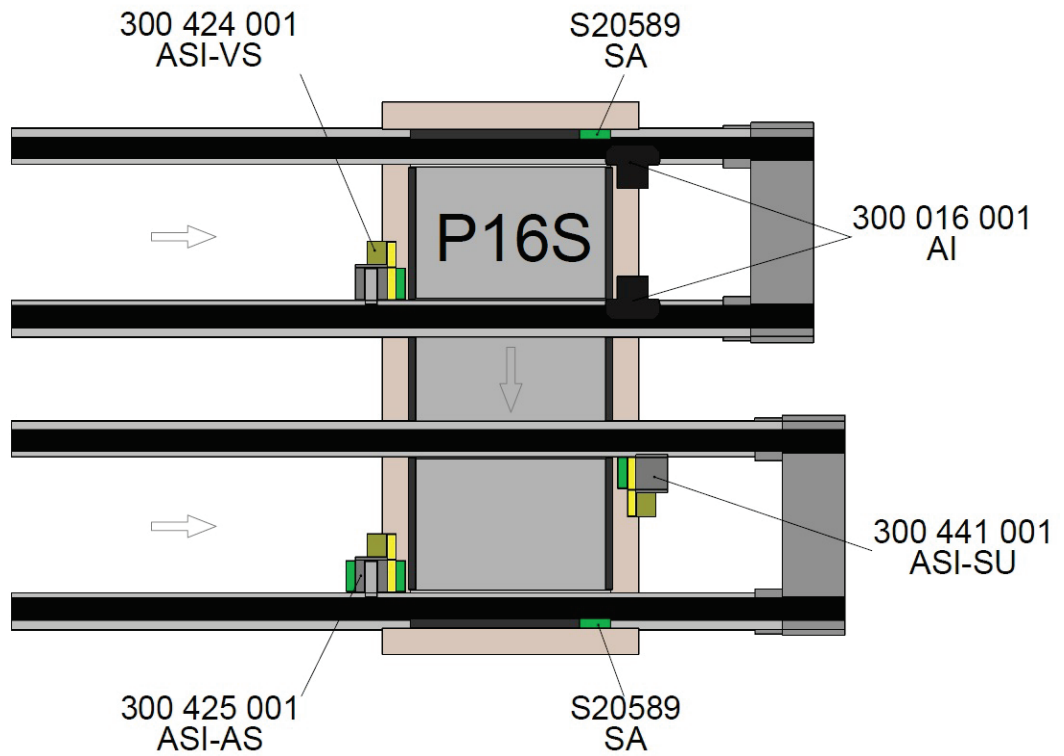

Fig. 9-16



9.9 P21S / P23S (A-workstation corner entry)

Fig. 9-17

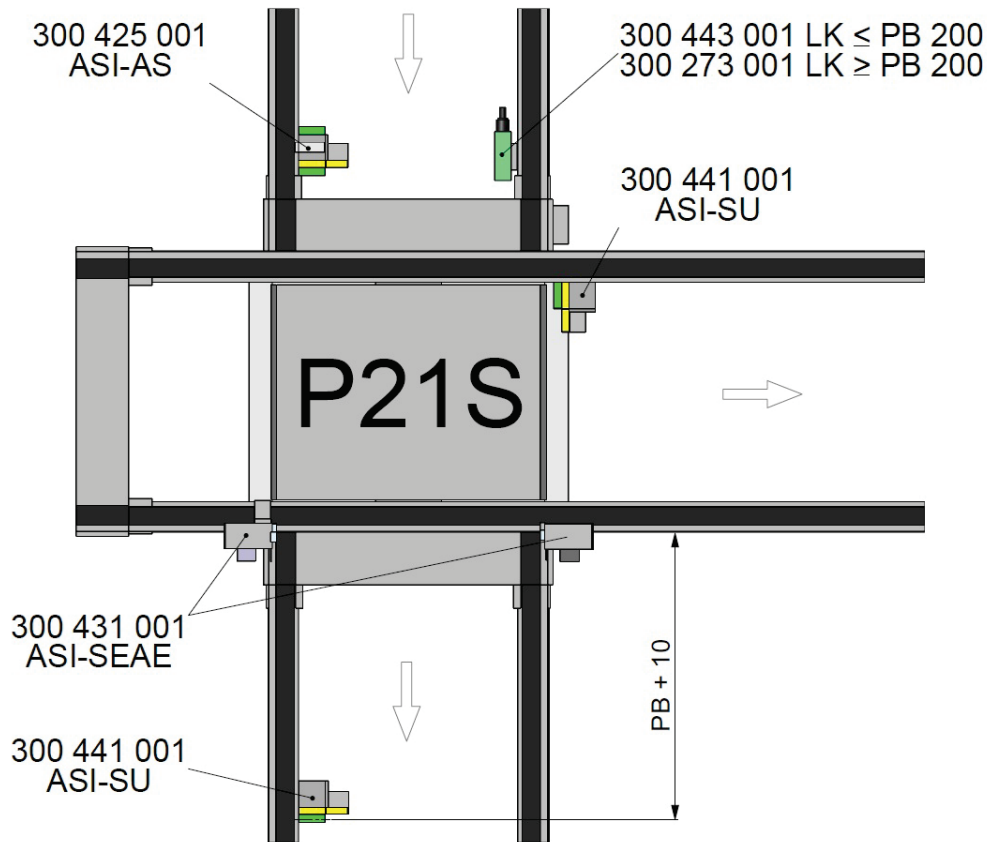
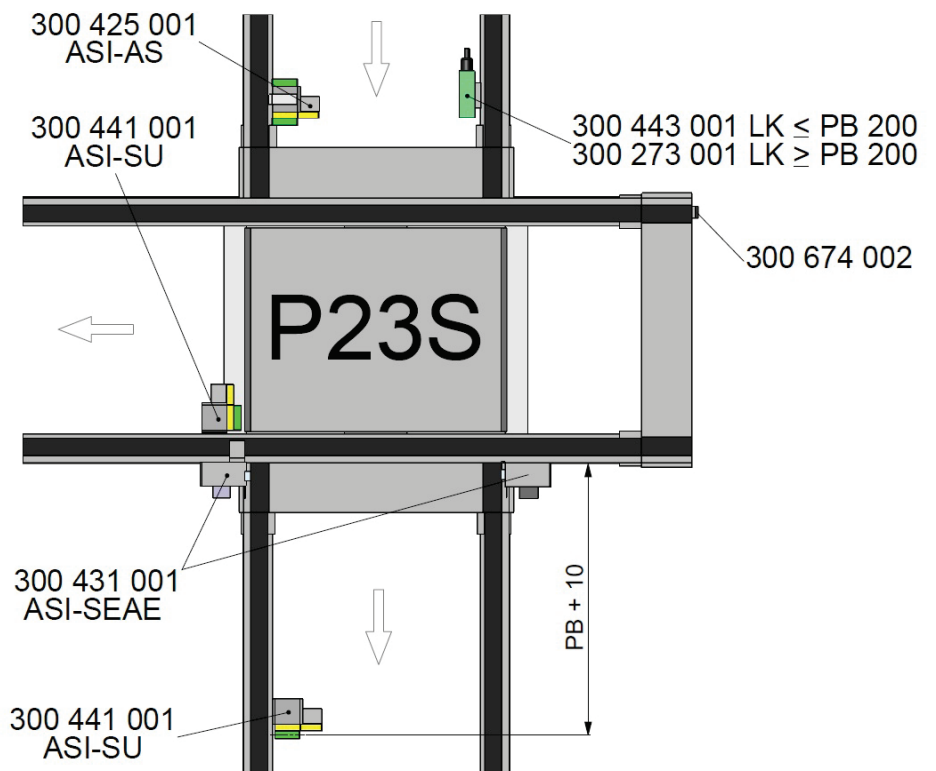

Fig. 9-18



9.10 P22S / P24S (A-workstation corner exit)

Fig. 9-19

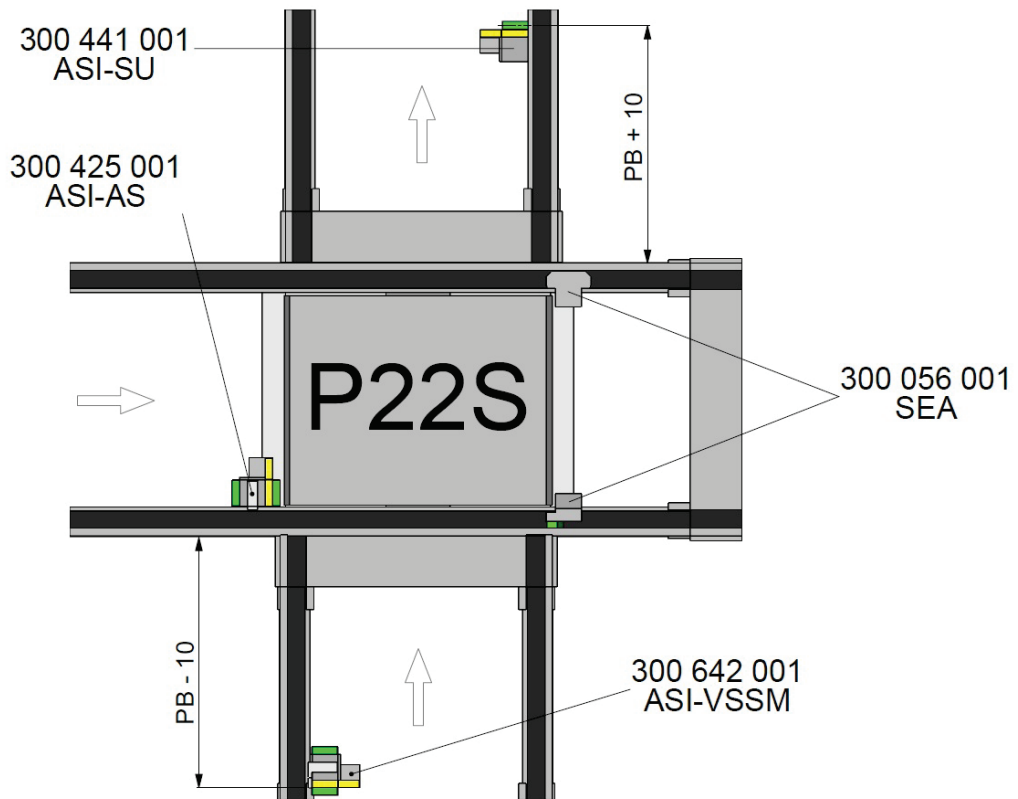
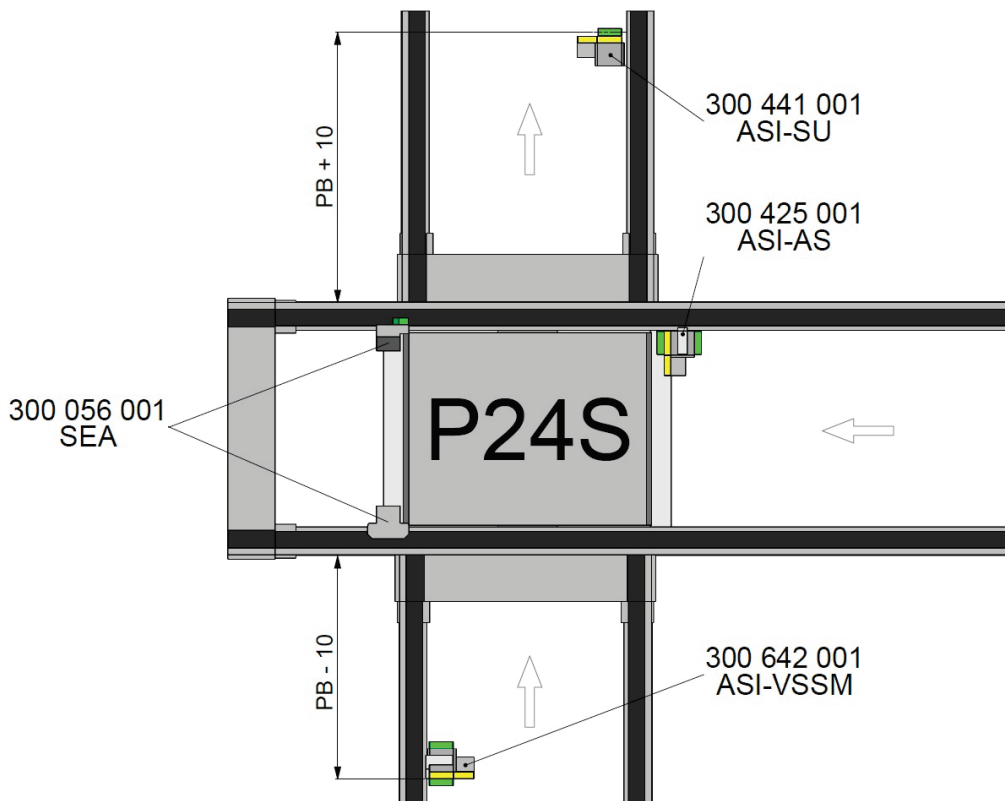

Fig. 9-20



9.11 P25S / P27S (B-workstation corner entry)

Fig. 9-21

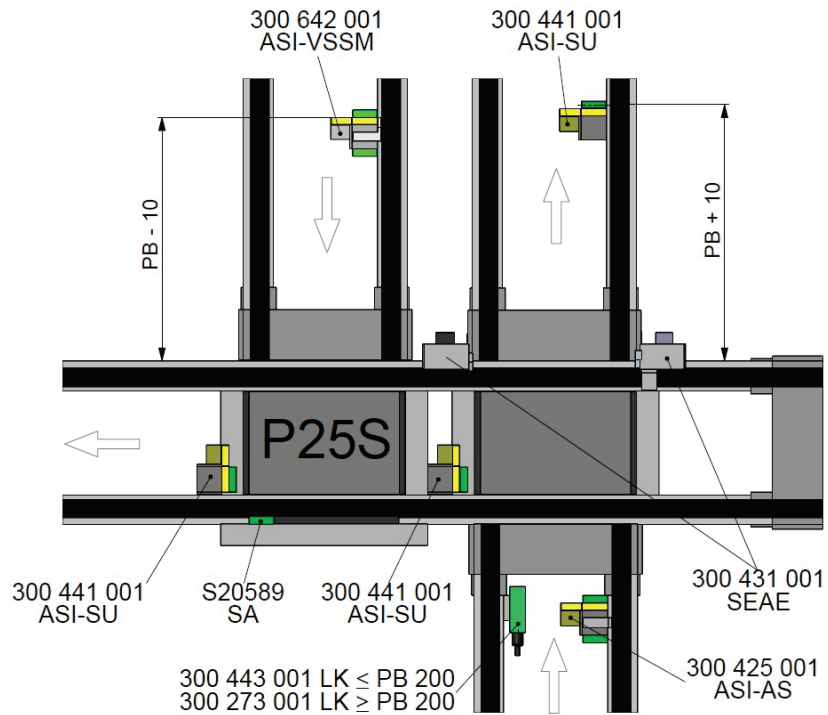
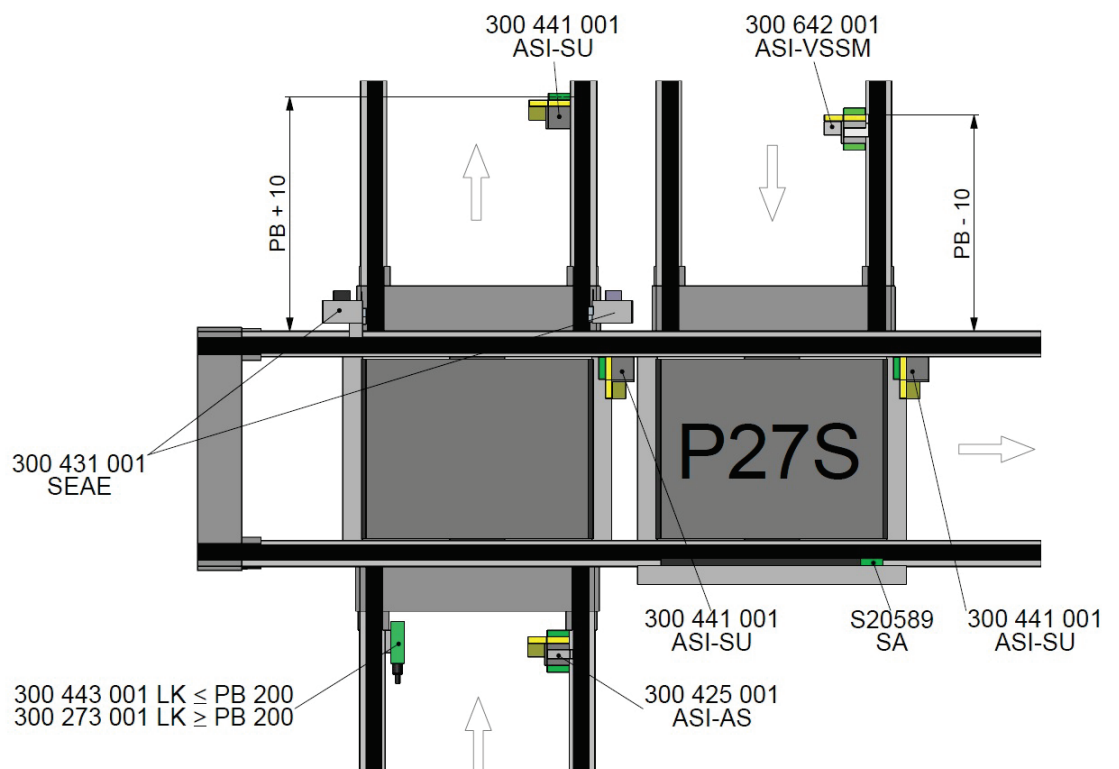

Fig. 9-22



9.12 P26S / P28S (B-workstation corner exit)

Fig. 9-23

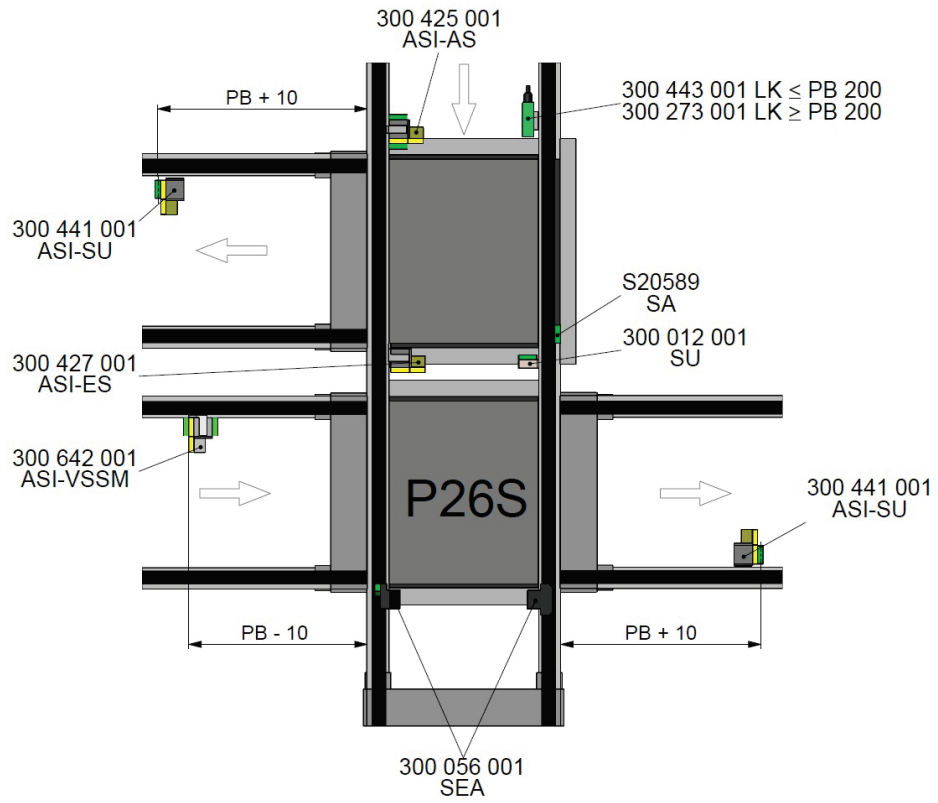
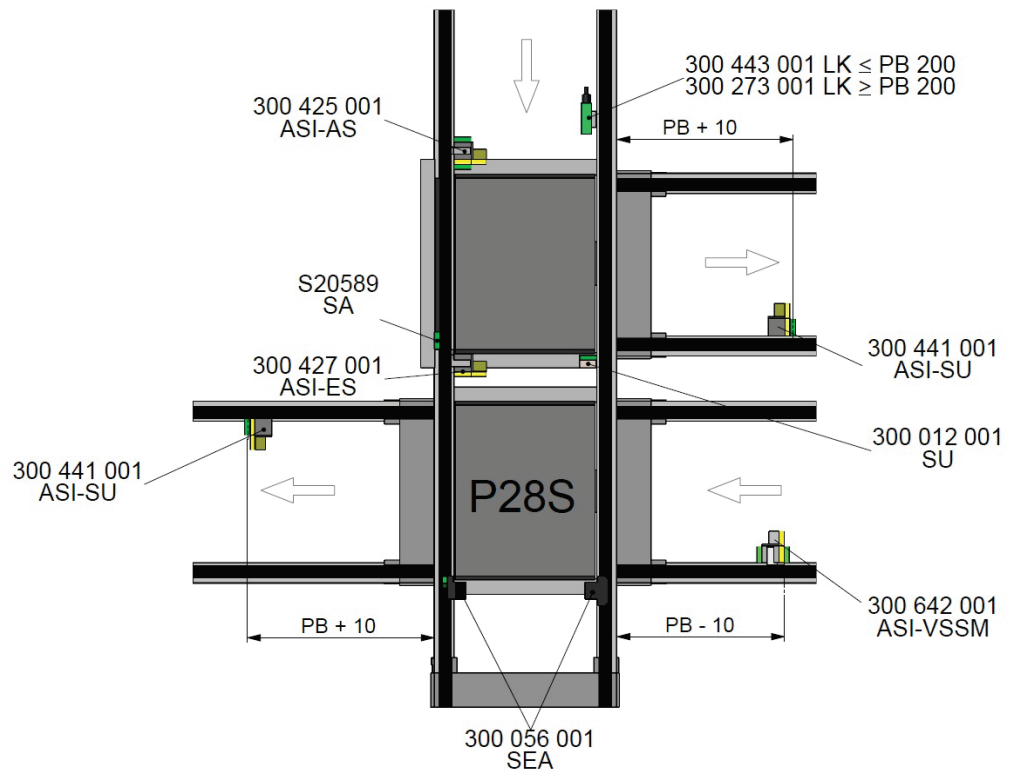

Fig. 9-24



9.13 P29S / P31S (C-workstation corner entry)

Fig. 9-25

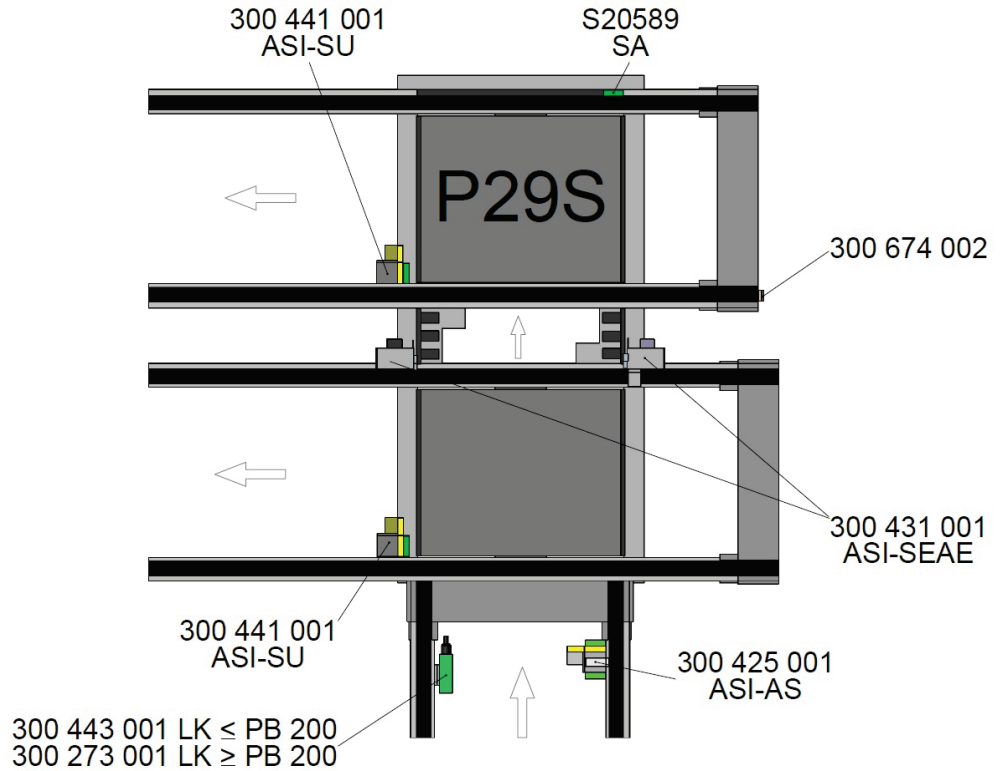
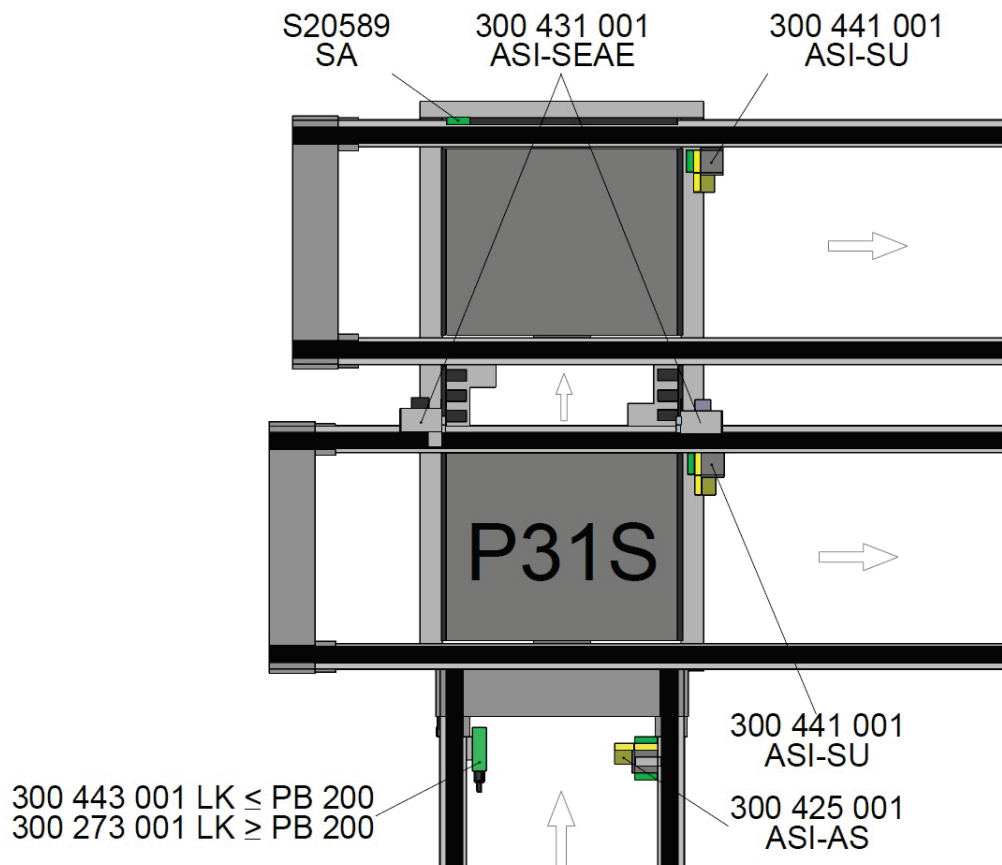

Fig. 9-26



9.14 P30S / P32S (C-workstation corner exit)

Fig. 9-27

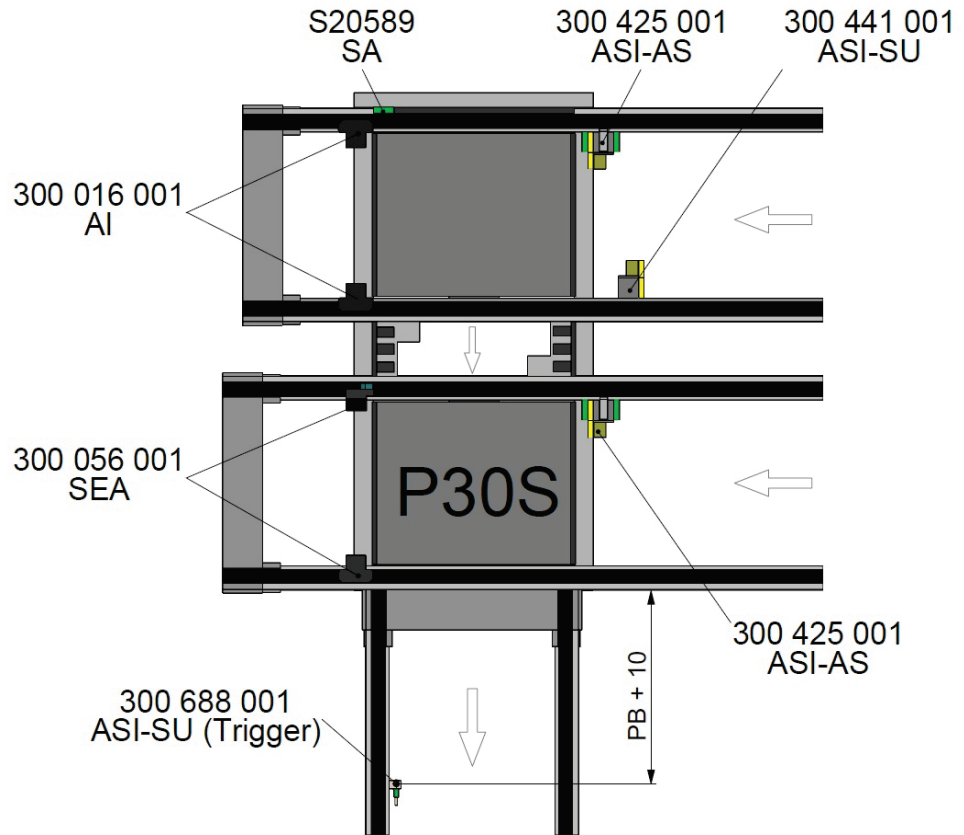
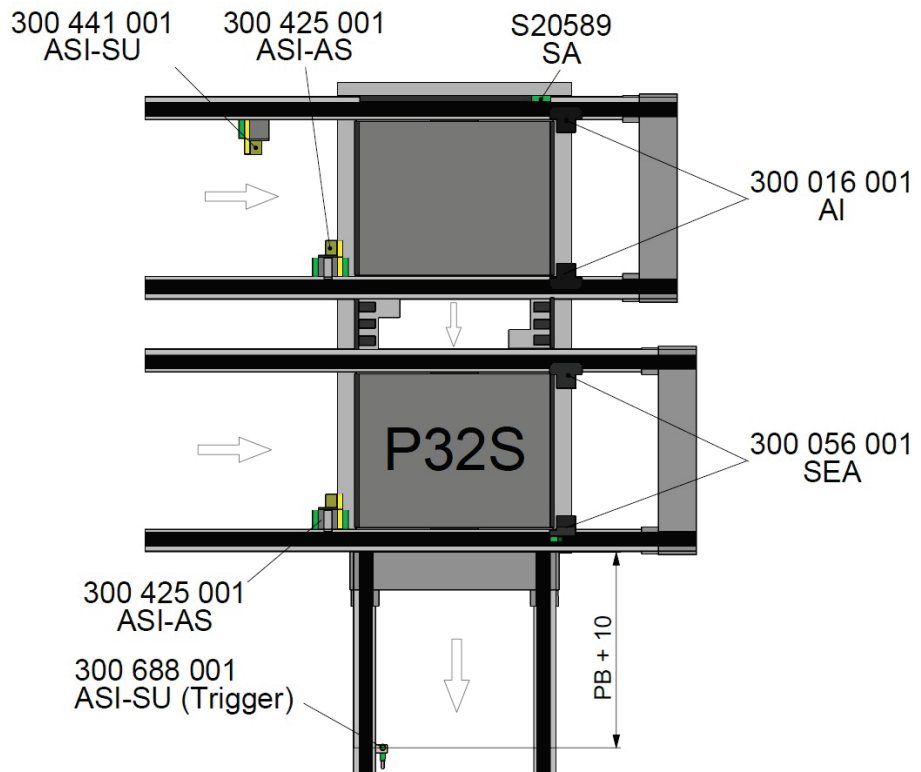

Fig. 9-28



10 P-Positions Soft Move 4G

10.1 P5S 4G / P7S 4G (A-workstation entry)

Abb. 10-1



Abb. 10-2



10.2 P11S 4G / P12S 4G (B-workstation entry)

Abb. 10-3

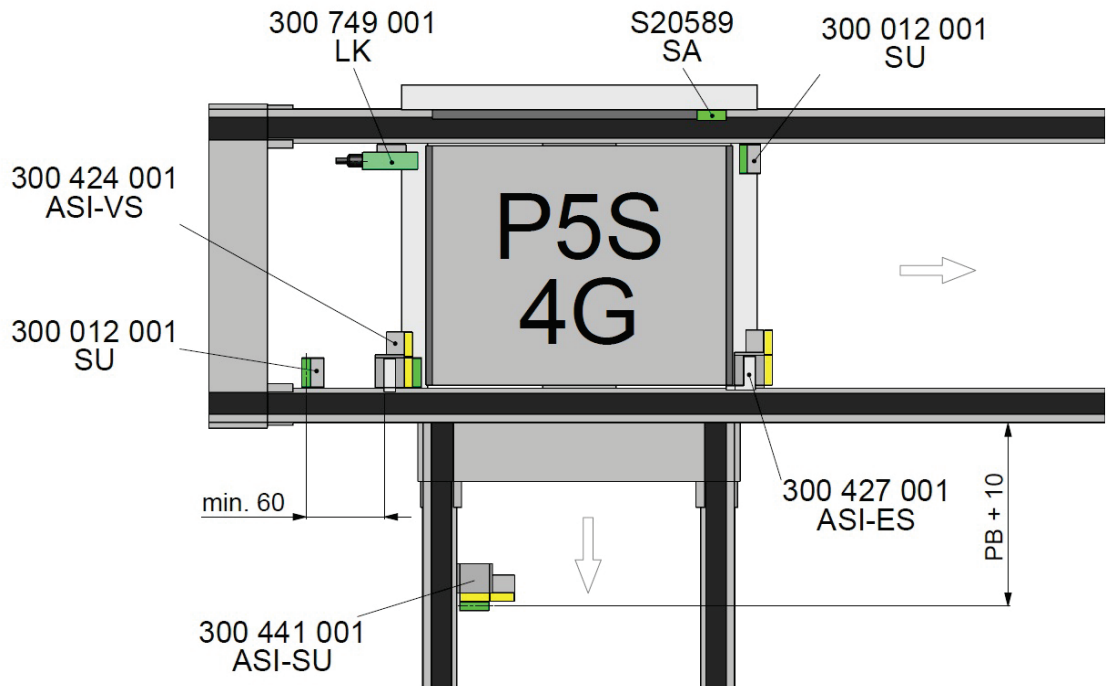
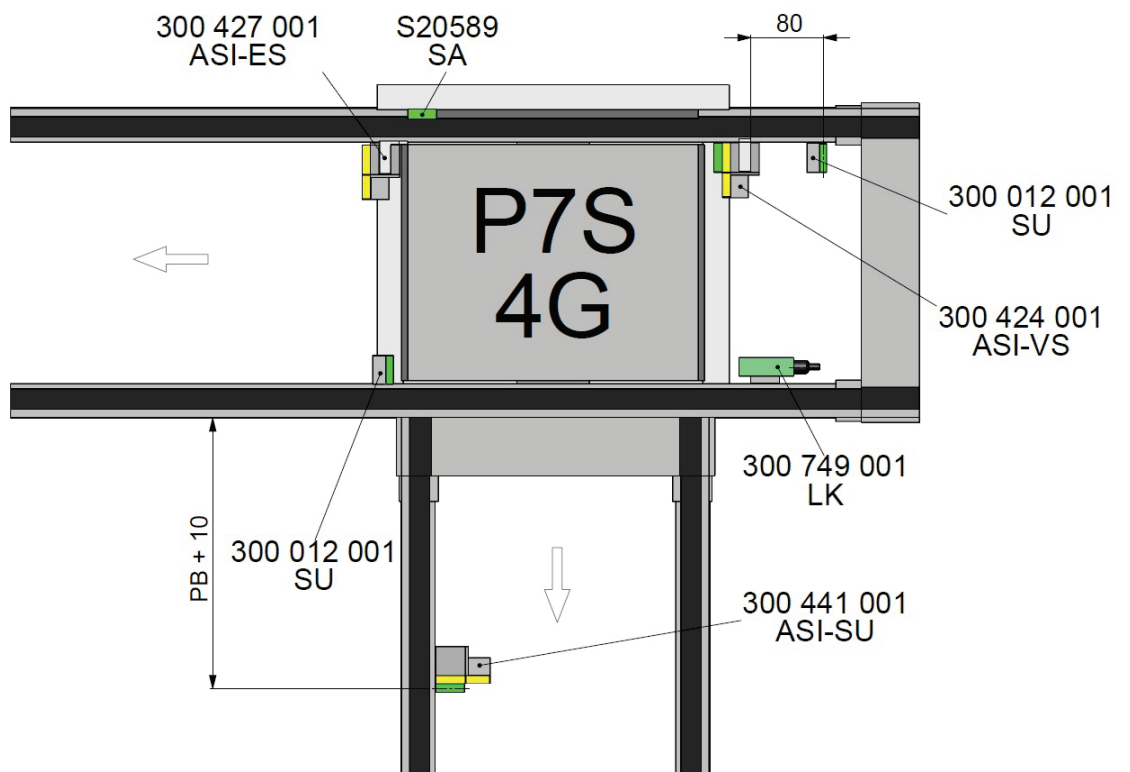

Abb. 10-4



10.3 P13S 4G / P15S 4G (C-workstation entry)

Abb. 10-5

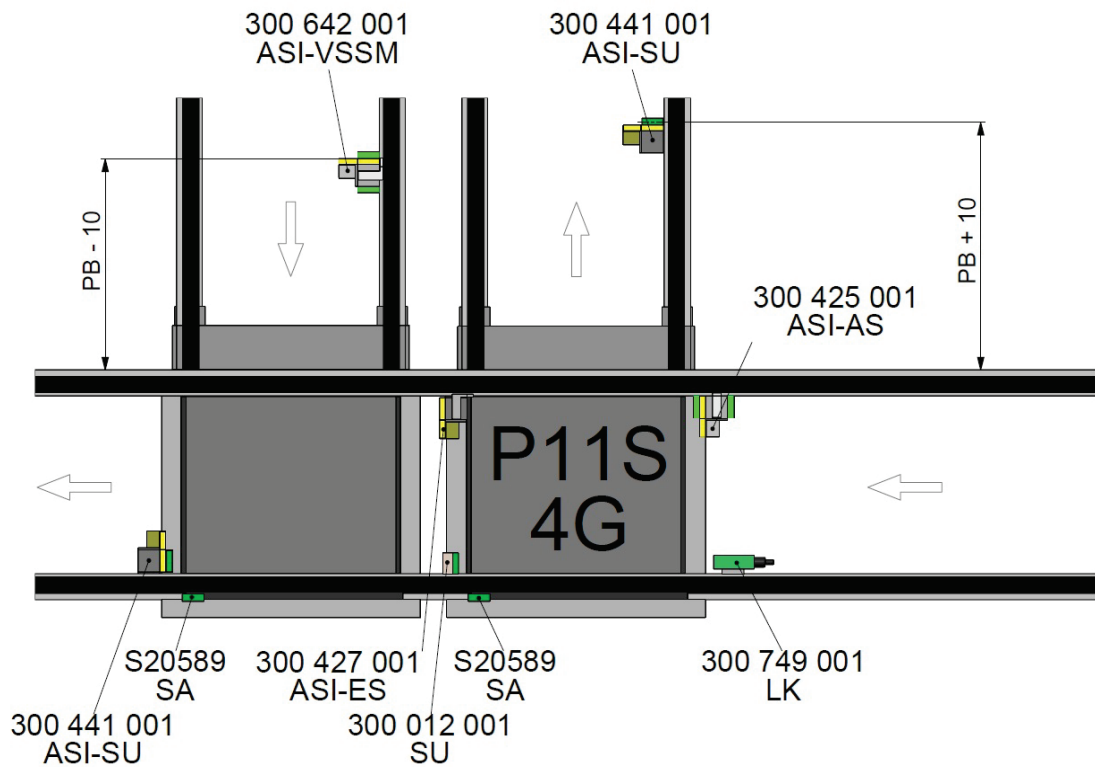
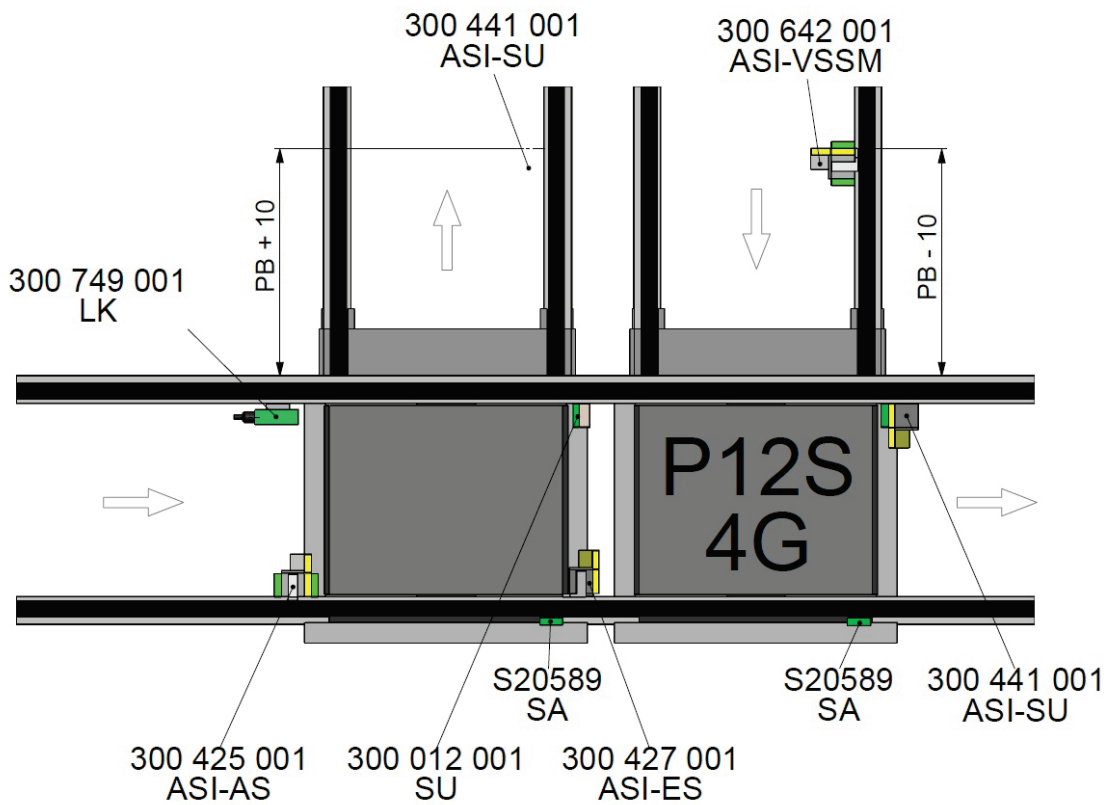

Abb. 10-6



10.4 P21S 4G / P23S 4G (A-workstation corner entry)

Abb. 10-7

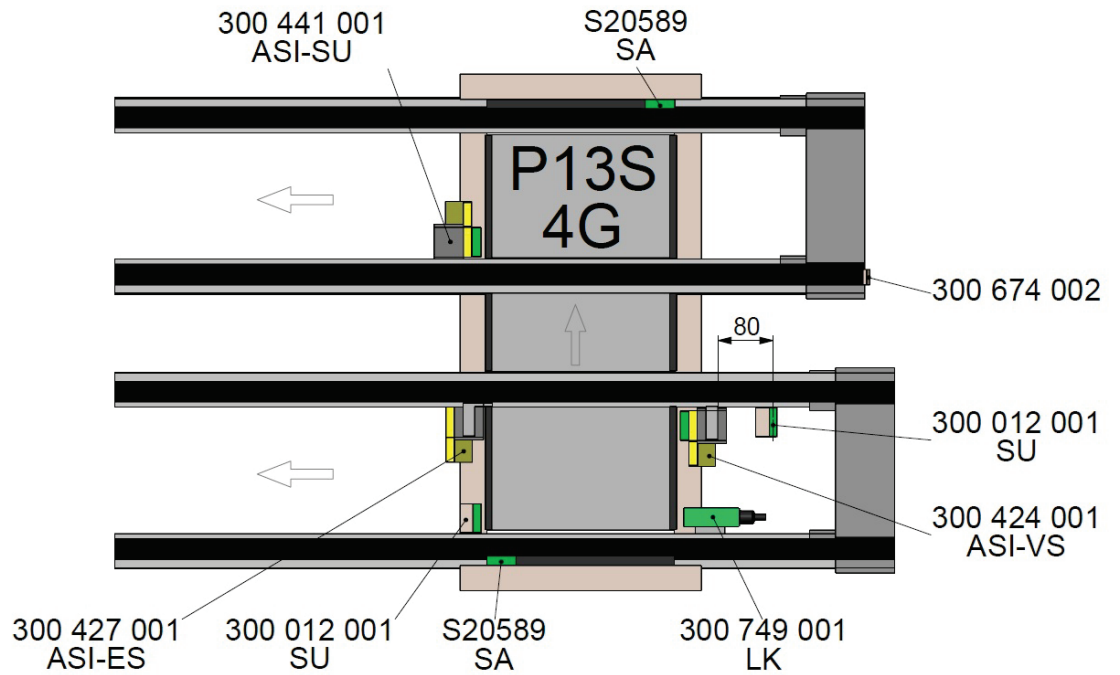
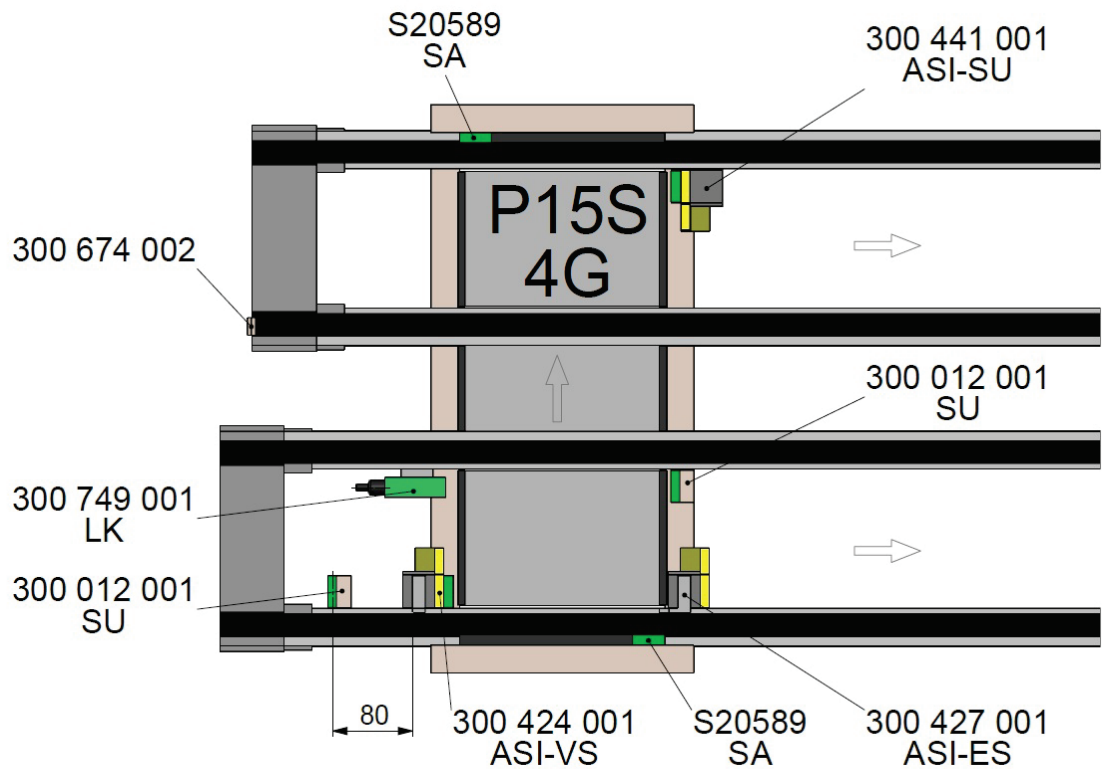

Abb. 10-8



10.5 P25S 4G / P27S 4G (B-workstation corner entry)

Abb. 10-9

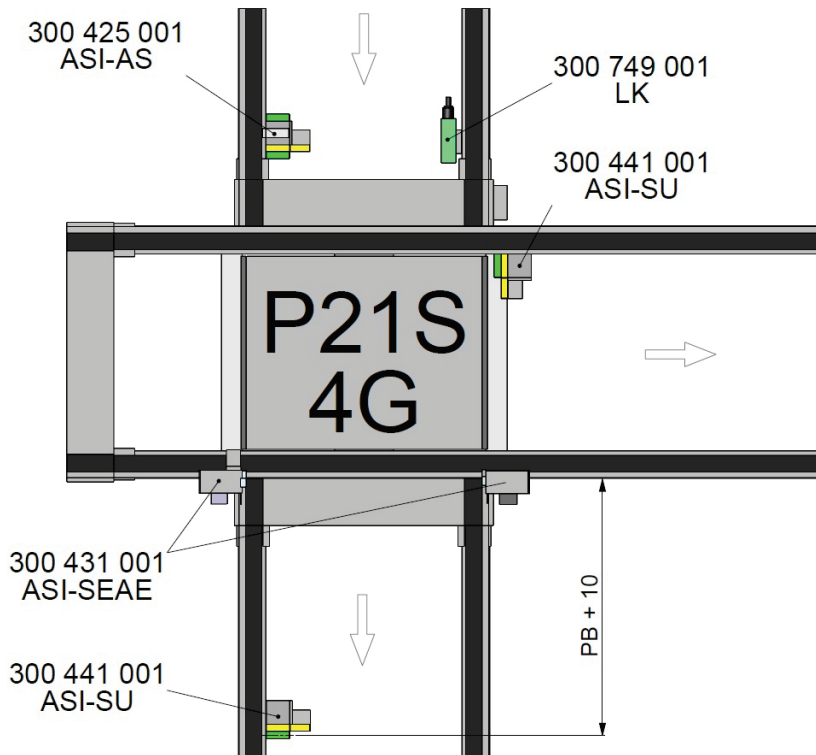
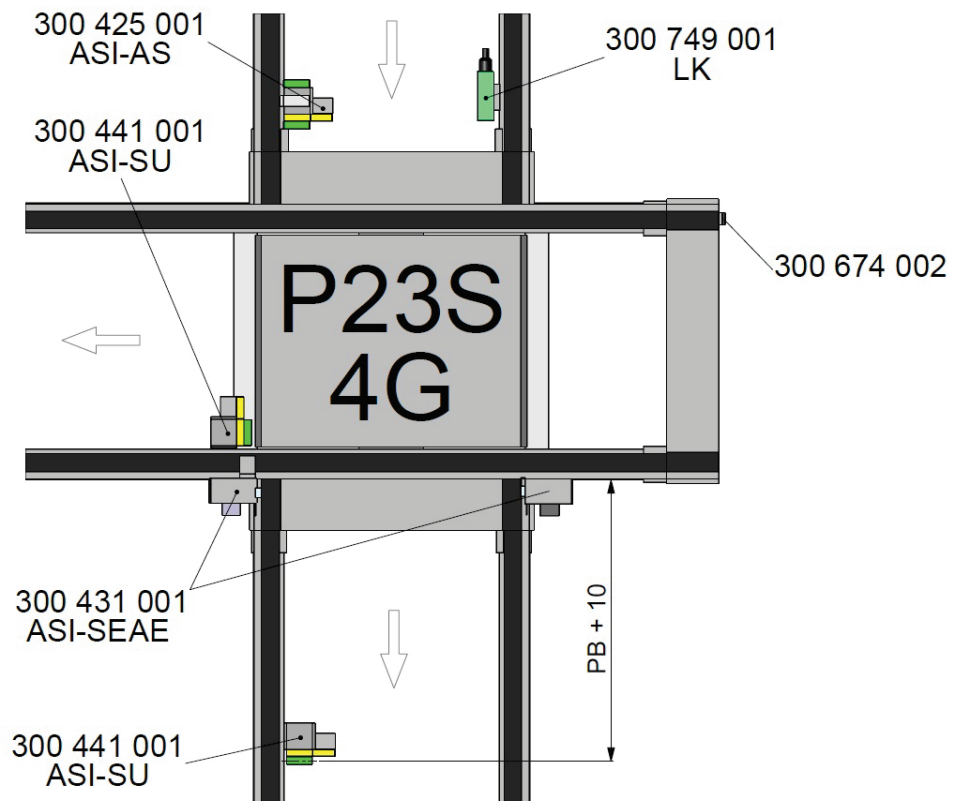

Abb. 10-10



10.6 P26S 4G / P28S 4G (B-workstation corner exit)

Abb. 10-11

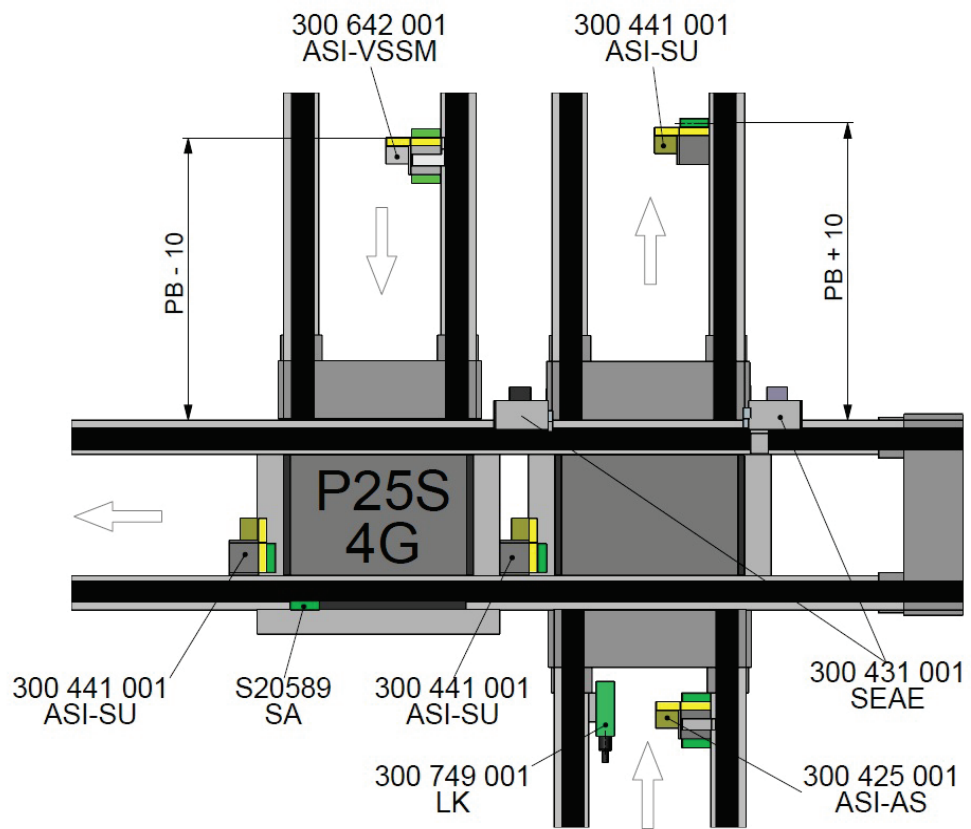
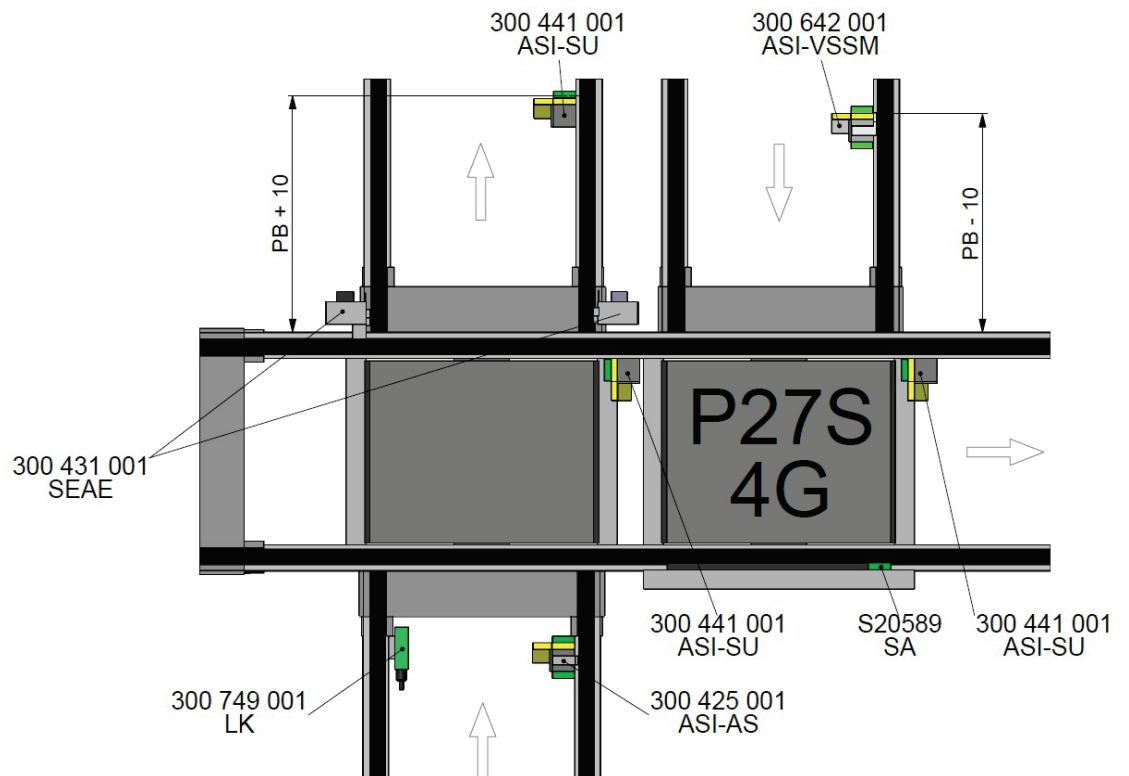

Abb. 10-12



10.7 P29S 4G / P31S 4G (C-workstation corner entry)

Abb. 10-13

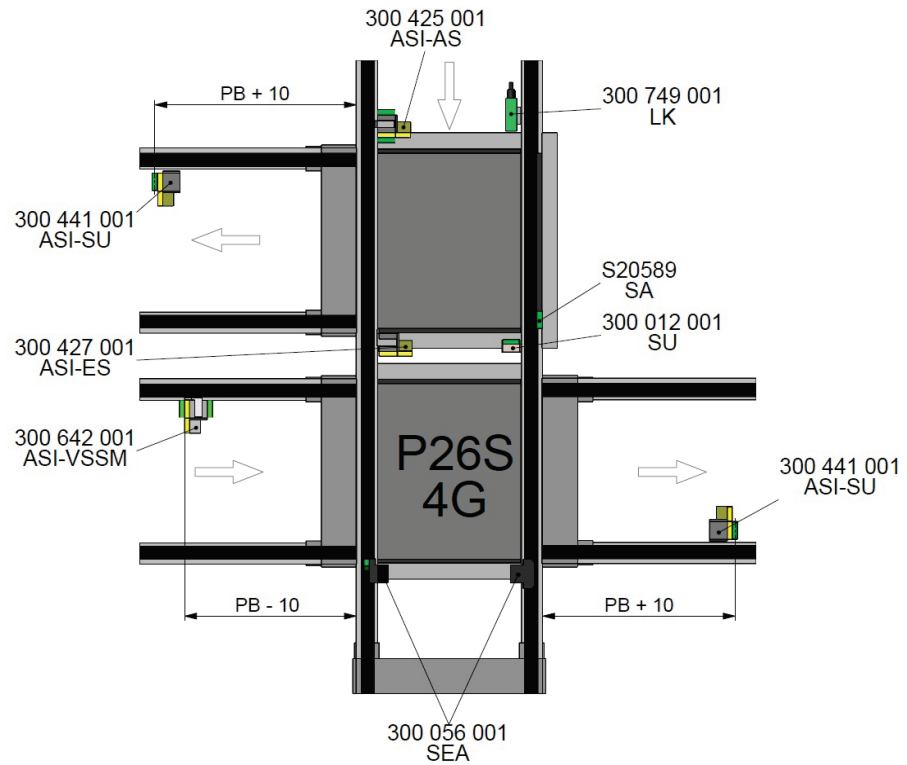
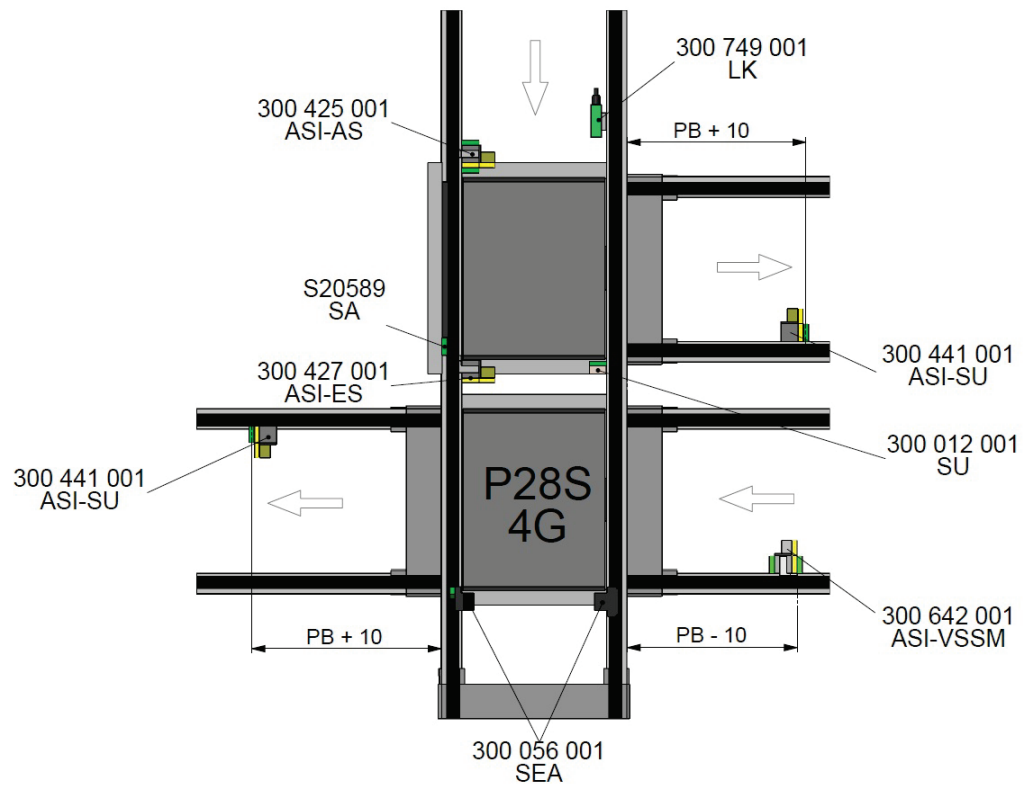

Abb. 10-14



11 Initial operation

Carry out the following checks before initial operation:

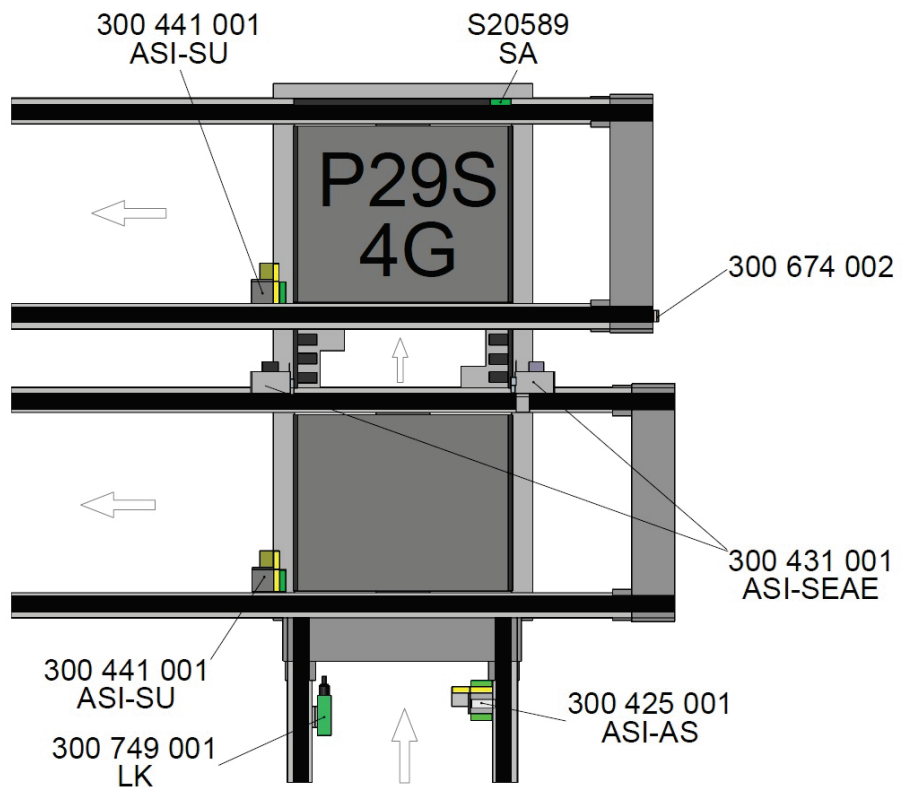
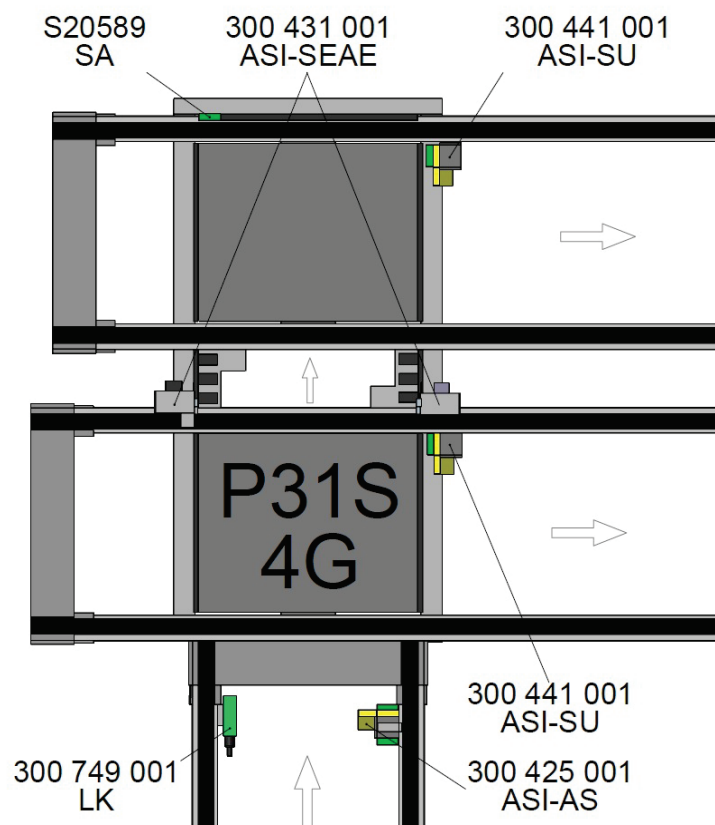
- Are all electrical cables undamaged?
- Are all the electric and pneumatic leads and hoses correctly connected?
- Have all the mechanical components been tightly fastened in place?
- Have all tools and other equipment been cleared from the transport area?
- Has all safety equipment been installed and is it working correctly?
- Are all the pallets in the correct position or is there a pallet queue?

Once you have carried out all these checks, you can continue with the initial operation.

- Switch on the Transport System and its associated processing stations and carry out a trial run.
- Check the functions of the individual devices and processing stations as well as the proper (programmed) interaction of the complete system.
- Check the safety equipment is functioning correctly.



WARNING!

Only start the Transport System once you have carried out a successful trial run.

12 Faults



WARNING!

When faults, malfunctions or damage affecting safety occur, immediately push the EMERGENCY STOP button to switch the Transport System off. Have the cause of the malfunction identified and the problem fixed by authorised personnel.

13 Cleaning and maintenance

13.1 Cleaning

Depending on the ambient conditions of the transport system, the stop device gets dirty
Clean the stop device regularly!
How frequently this must be done depends on how dirty it gets.



Cleaning does not mean the transport system needs to be dismantled.



DANGER!

From unexpected start-up of the Transport System.



DANGER!

HIGH ELECTRICAL VOLTAGE
Electric shock hazard

- 1 Disconnect the Workpiece Transport System in question from the electrical power supply before carrying out any cleaning work!
- 2 Put up warning signs to prevent the system being started up while installation and repair work is being done.
- 3 Remove the pallets from the Transport System.



Protective clothing must be worn

When cleaning, wear goggles, safety gloves and a dust-mask, if necessary.
Only use a vacuum cleaner to remove dust, shavings and other particles.

- 4 Remove dust, shavings and other particles with a vacuum cleaner.
- 5 Clean dirty surfaces with a soft, lint free cloth, lightly dampened with cleaning fluid.



WARNING

When cleaning, do not use any abrasive, corrosive or scouring cleaning fluids or cleaning materials.

Avoid fluid getting into the components of the system or of the processing stations.



STEIN Automation recommends the industrial cleaner by Würth,
Article no.: 893 140 or Arecal Clean manufactured by RECA Norm,
article no.: 0895014500.

Keep the upper belt surface in good condition by regularly applying Carbaflo[®] XTR5 F.
See brief instructions for the conditioning fluid Carbaflo[®] XTR5 F.



Environmental protection.

Dispose of waste material and used cleaning cloths in an environmentally responsible way.

13.2 Maintenance

The stop devices are maintenance-free.

14 Appendix

14.1 Technical data

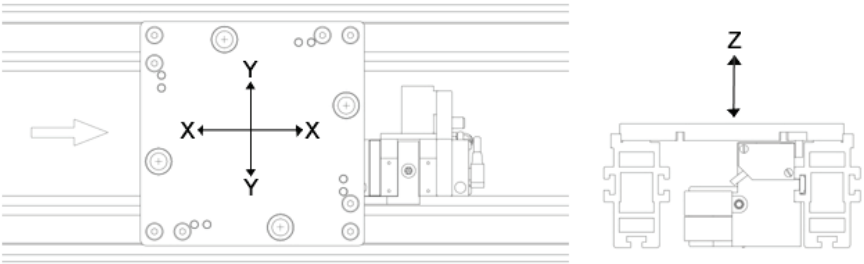
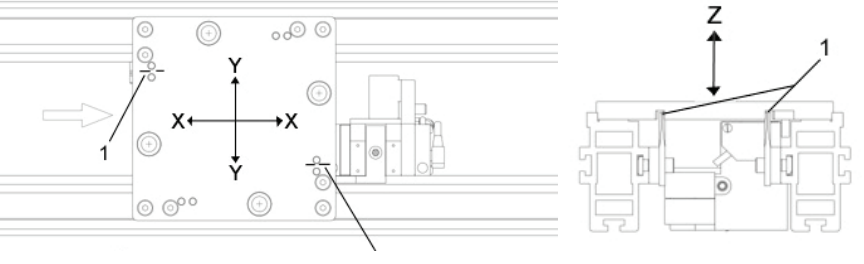
Stop device	
Sizes available	For pallets 160x160 to 400 x 400 mm (any size within this range)
Permissible pallet load	 <p>Stop device:</p> <ul style="list-style-type: none"> • in the X axis: none • in the Y axis: 100 N • in the Z axis: 50 N
	 <p>Stop devices with centring rails:</p> <ul style="list-style-type: none"> • in the X axis: none • in the Y axis: 100 N • in the Z axis: 50 N
ASI electronic Electrical / Pneumatic connections	Technical data of the ASI electronic and connections can be found in chapter 6 and 6.1.

This information reflects the technical status at the time of printing.
STEIN Automation reserves the right to make technical updates.

STEIN Automation GmbH & Co. KG

Carl-Haag-Straße 26
78054 VS-Schwenningen

Telephone +49 (0)7720 / 8307-0
info@stein-automation.de

www.stein-automation.de